

2

1

B

B

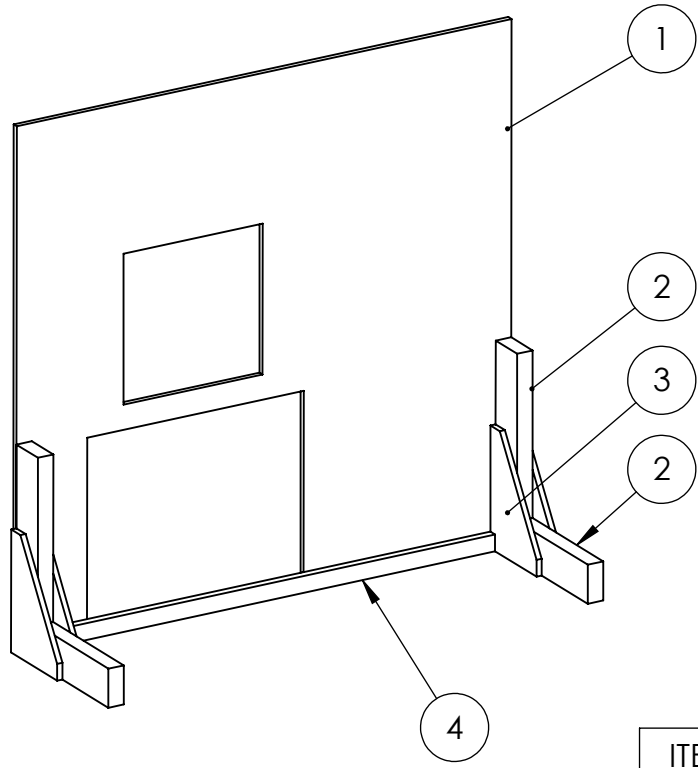

ITEM NO.	PART NUMBER	DESCRIPTION	QTY.
1	TE-18001-01		1
2	TE-18001-02		4
3	TE-18001-03		4
4	TE-18001-04		1

A

A

PROPRIETARY AND CONFIDENTIAL

THE INFORMATION CONTAINED IN THIS DRAWING IS THE SOLE PROPERTY OF **FIRST®**. Any REPRODUCTION IN PART OR AS A WHOLE WITHOUT THE WRITTEN PERMISSION OF **FIRST®**S PROHIBITED.

		UNLESS OTHERWISE SPECIFIED:		NAME	DATE
		DIMENSIONS ARE IN INCHES	DRAWN		
		TOLERANCES:	CHECKED		
		FRACTIONAL ± 1/16	ENG APPR.		
		ANGULAR: MACH ± 1° BEND ± 1°	MFG APPR.		
		TWO PLACE DECIMAL ± .01	Q.A.		
		THREE PLACE DECIMAL ± .001	COMMENTS:		
		INTERPRET GEOMETRIC TOLERANCING PER:			
		MATERIAL			
		FINISH			
NEXT ASSY	USED ON				
	APPLICATION	DO NOT SCALE DRAWING			



TITLE: **Exchange**

SIZE **A** DWG. NO. **TE-18001** REV

SCALE: 1:16 WEIGHT: SHEET 1 OF 2

2

1

2

1

B

B

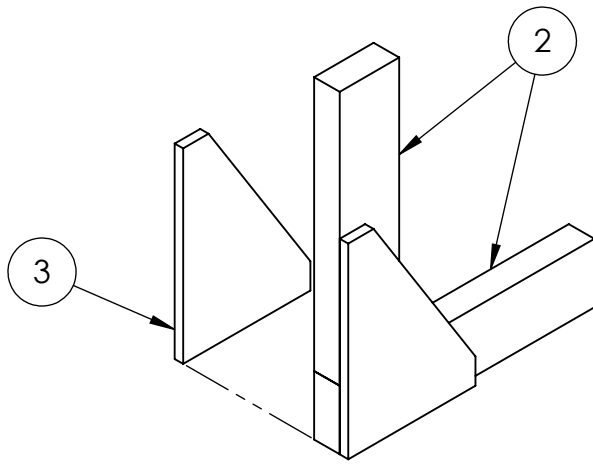

Attach Item 2 (Qty. 2) and Item 3 (Qty. 2) as shown with wood screws. Build two total.

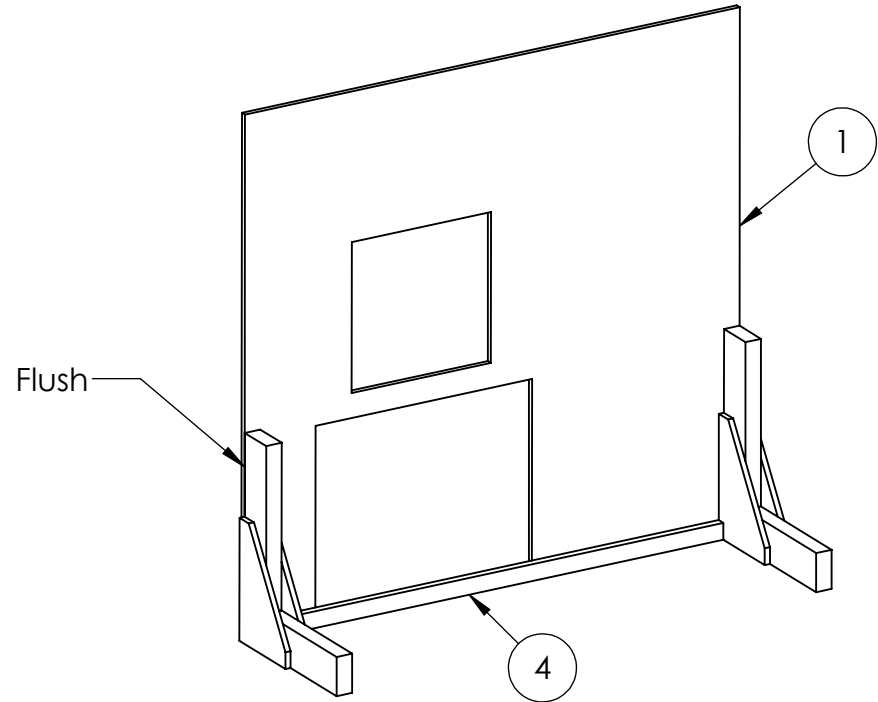

Using wood screws, attach the two leg assemblies to Item 1, so that the 2x4 is flush with the edge of the plywood. Place Item 4 between the two leg assemblies and secure with screws.

A

A

PROPRIETARY AND CONFIDENTIAL
 THE INFORMATION CONTAINED IN THIS DRAWING IS THE SOLE PROPERTY OF **FIRST®**. ANY REPRODUCTION IN PART OR AS A WHOLE WITHOUT THE WRITTEN PERMISSION OF **FIRST®** IS PROHIBITED.

		UNLESS OTHERWISE SPECIFIED:		NAME	DATE
		DIMENSIONS ARE IN INCHES	DRAWN		
		TOLERANCES:	CHECKED		
		FRACTIONAL ± 1/16	ENG APPR.		
		ANGULAR: MACH ± 1° BEND ± 1°	MFG APPR.		
		TWO PLACE DECIMAL ± .01	Q.A.		
		THREE PLACE DECIMAL ± .001	COMMENTS:		
		INTERPRET GEOMETRIC TOLERANCING PER:			
		MATERIAL			
NEXT ASSY	USED ON	FINISH			
APPLICATION		DO NOT SCALE DRAWING			



TITLE:		
<h1>Exchange</h1>		
SIZE	DWG. NO.	REV
A	TE-18001	
SCALE: 1:16 WEIGHT:		SHEET 2 OF 2

2

1

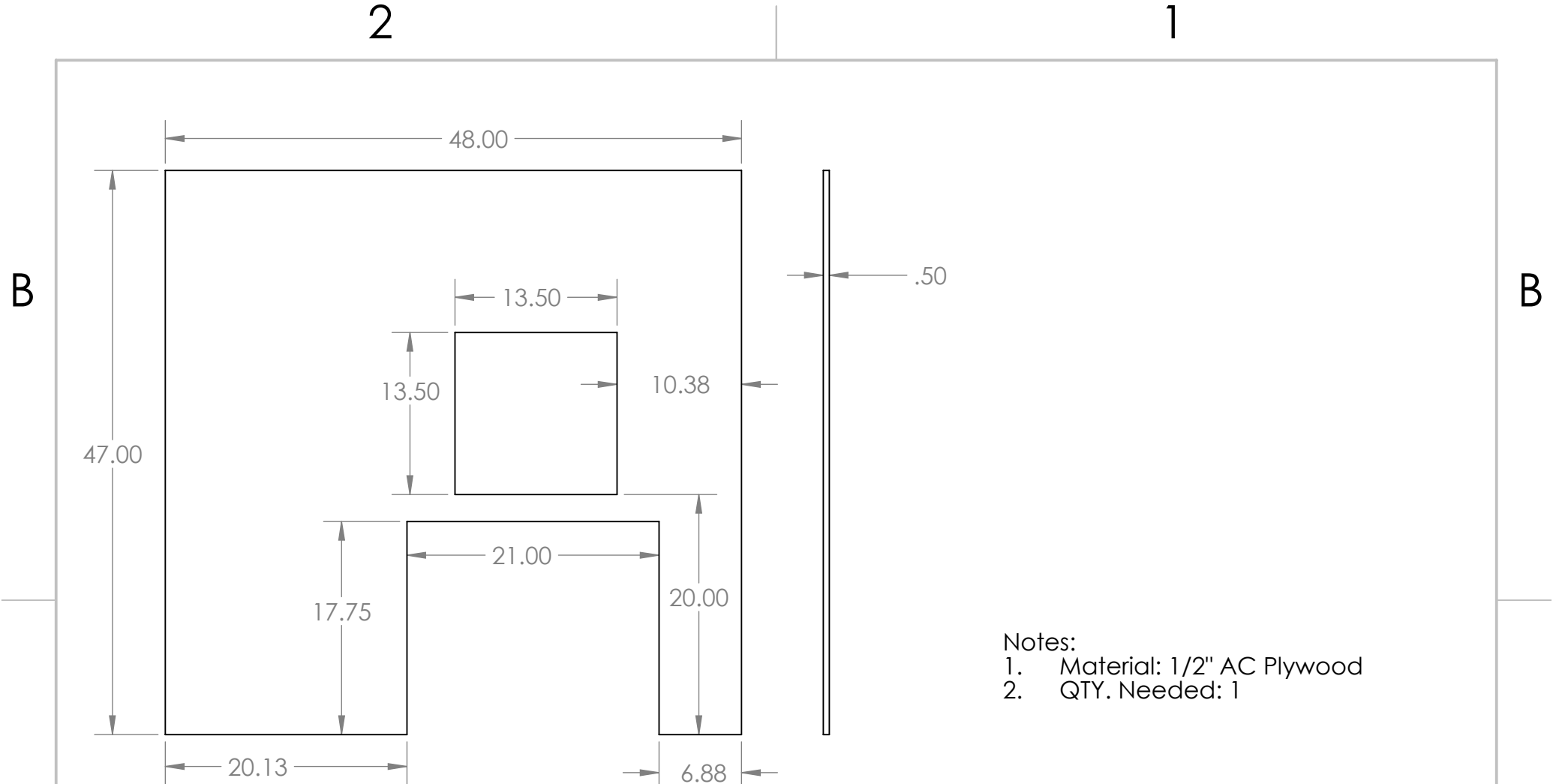



- Notes:
1. Material: 1/2" AC Plywood
 2. QTY. Needed: 1

A

A

PROPRIETARY AND CONFIDENTIAL
 THE INFORMATION CONTAINED IN THIS DRAWING IS THE SOLE PROPERTY OF **FIRST®**. Any REPRODUCTION IN PART OR AS A WHOLE WITHOUT THE WRITTEN PERMISSION OF **FIRST®** IS PROHIBITED.

		UNLESS OTHERWISE SPECIFIED:		NAME	DATE
		DIMENSIONS ARE IN INCHES	DRAWN		
		TOLERANCES:	CHECKED		
		FRACTIONAL ± 1/16	ENG APPR.		
		ANGULAR: MACH ± 1° BEND ± 1°	MFG APPR.		
		TWO PLACE DECIMAL ± .01	Q.A.		
		THREE PLACE DECIMAL ± .001	COMMENTS:		
		INTERPRET GEOMETRIC TOLERANCING PER:			
		MATERIAL			
		FINISH			
NEXT ASSY	USED ON				
APPLICATION		DO NOT SCALE DRAWING			

TITLE:

SIZE	DWG. NO.	REV
A	TE-18001-01	
SCALE: 1:12	WEIGHT:	SHEET 1 OF 1

2

1

2

1

B

B

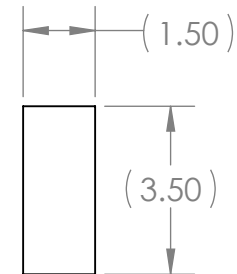
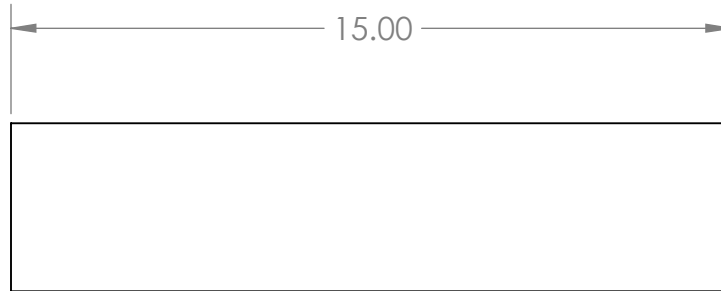



Notes:

- 1. Material: 2" x 4" Pine Lumber
- 2. QTY Needed: 4

A

A

		UNLESS OTHERWISE SPECIFIED:			NAME	DATE	 	
		DIMENSIONS ARE IN INCHES		DRAWN			TITLE:	
		TOLERANCES:		CHECKED				
		FRACTIONAL ± 1/16		ENG APPR.				
		ANGULAR: MACH ± 1° BEND ± 1°		MFG APPR.				
		TWO PLACE DECIMAL ± .01		Q.A.			SIZE DWG. NO. REV A TE-18001-02	
		THREE PLACE DECIMAL ± .001		COMMENTS:				
		INTERPRET GEOMETRIC TOLERANCING PER:						
		MATERIAL						
		FINISH						
		NEXT ASSY	USED ON					
		APPLICATION		DO NOT SCALE DRAWING			SCALE: 1:4 WEIGHT: SHEET 1 OF 1	

PROPRIETARY AND CONFIDENTIAL

THE INFORMATION CONTAINED IN THIS DRAWING IS THE SOLE PROPERTY OF **FIRST®**. Any REPRODUCTION IN PART OR AS A WHOLE WITHOUT THE WRITTEN PERMISSION OF **FIRST®**S PROHIBITED.

2

1

2

1

B

B

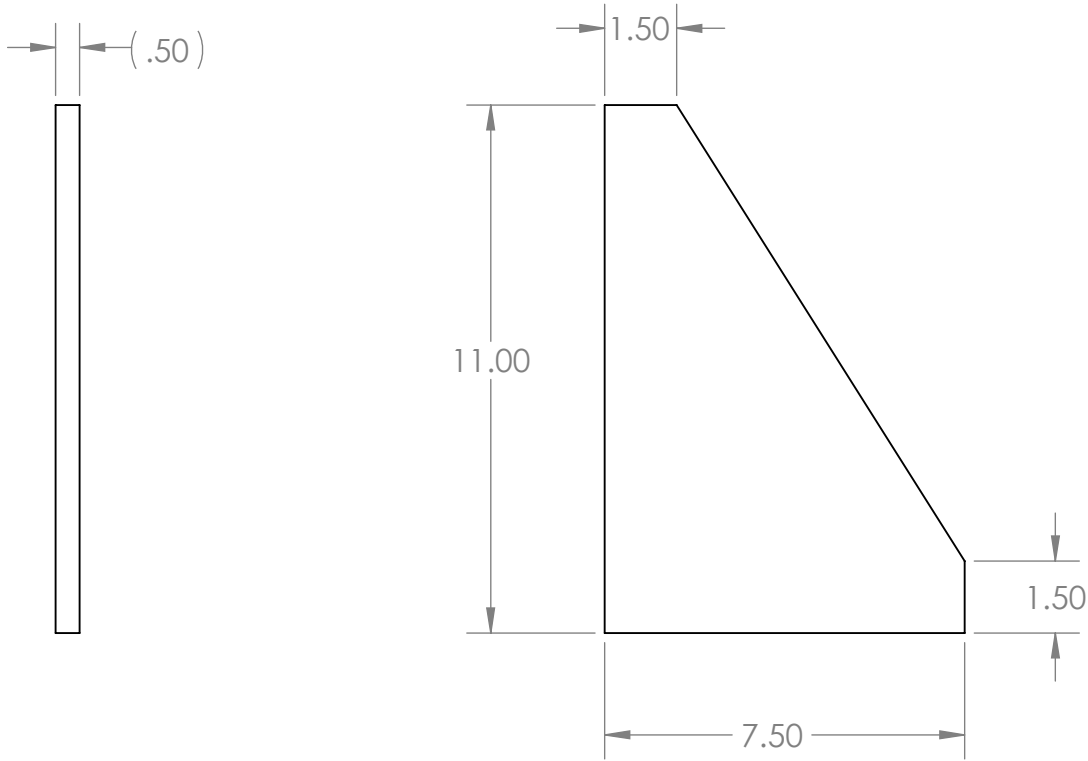

Notes:

- 1. Material: 1/2" AC Plywood
- 2. QTY. Needed: 4

A

A

		UNLESS OTHERWISE SPECIFIED:		NAME	DATE
		DIMENSIONS ARE IN INCHES	DRAWN		
		TOLERANCES:	CHECKED		
		FRACTIONAL ± 1/16	ENG APPR.		
		ANGULAR: MACH ± 1° BEND ± 1°	MFG APPR.		
		TWO PLACE DECIMAL ± .01	Q.A.		
		THREE PLACE DECIMAL ± .001	COMMENTS:		
		INTERPRET GEOMETRIC TOLERANCING PER:			
		MATERIAL			
		FINISH			
	NEXT ASSY	USED ON			
	APPLICATION				
		DO NOT SCALE DRAWING			



TITLE:		
SIZE	DWG. NO.	REV
A	TE-18001-03	
SCALE: 1:4	WEIGHT:	SHEET 1 OF 1

PROPRIETARY AND CONFIDENTIAL

THE INFORMATION CONTAINED IN THIS DRAWING IS THE SOLE PROPERTY OF **FIRST®**. Any REPRODUCTION IN PART OR AS A WHOLE WITHOUT THE WRITTEN PERMISSION OF **FIRST®**S PROHIBITED.

2

1

2

1

B

B

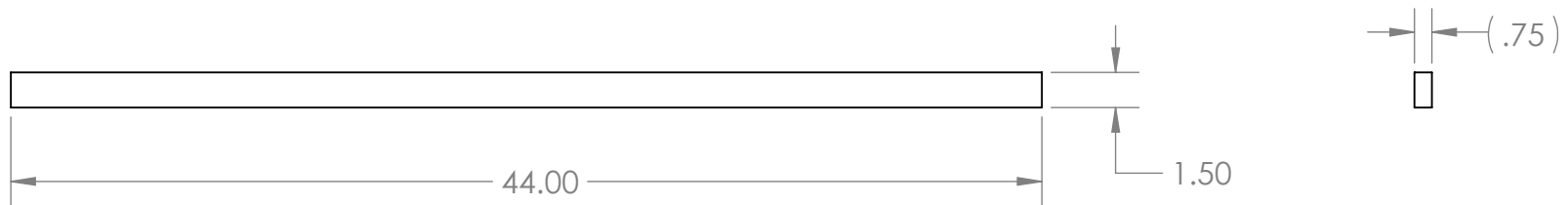

NOTES:

- 1. Material: 3/4" AC Plywood
- 2. QTY. Needed: 1

A

A

PROPRIETARY AND CONFIDENTIAL
 THE INFORMATION CONTAINED IN THIS DRAWING IS THE SOLE PROPERTY OF **FIRST®**. Any REPRODUCTION IN PART OR AS A WHOLE WITHOUT THE WRITTEN PERMISSION OF **FIRST®** IS PROHIBITED.

		UNLESS OTHERWISE SPECIFIED:		NAME	DATE
		DIMENSIONS ARE IN INCHES	DRAWN		
		TOLERANCES:	CHECKED		
		FRACTIONAL ± 1/16	ENG APPR.		
		ANGULAR: MACH ± 1° BEND ± 1°	MFG APPR.		
		TWO PLACE DECIMAL ± .01	Q.A.		
		THREE PLACE DECIMAL ± .001	COMMENTS:		
		INTERPRET GEOMETRIC TOLERANCING PER:			
		MATERIAL			
		.75 Ply			
NEXT ASSY	USED ON	FINISH			
		APPLICATION			
		DO NOT SCALE DRAWING			



TITLE:		
SIZE	DWG. NO.	REV
A	TE-18001-04	
SCALE: 1:8	WEIGHT:	SHEET 1 OF 1

2

1

B

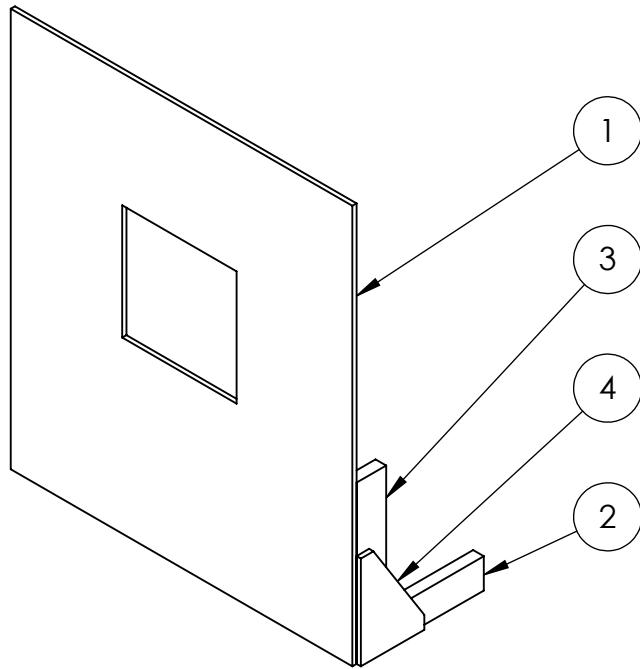

1



B

ITEM NO.	PART NUMBER	DESCRIPTION	QTY.
1	TE-18002-1		1
2	TE-18002-2		2
3	TE-18002-3		2
4	TE-18002-4		4

A

A

PROPRIETARY AND CONFIDENTIAL
 THE INFORMATION CONTAINED IN THIS DRAWING IS THE SOLE PROPERTY OF **FIRST®**. Any REPRODUCTION IN PART OR AS A WHOLE WITHOUT THE WRITTEN PERMISSION OF **FIRST®** IS PROHIBITED.

		UNLESS OTHERWISE SPECIFIED:		NAME	DATE	 	
		DIMENSIONS ARE IN INCHES	DRAWN				TITLE: <h1 style="text-align: center;">Portal</h1>
		TOLERANCES:	CHECKED				
		FRACTIONAL $\pm 1/16$	ENG APPR.				
		ANGULAR: MACH $\pm 1^\circ$ BEND $\pm 1^\circ$	MFG APPR.				
		TWO PLACE DECIMAL $\pm .01$	Q.A.			SIZE DWG. NO. REV A TE-18002	
		THREE PLACE DECIMAL $\pm .001$	COMMENTS:				
		INTERPRET GEOMETRIC TOLERANCING PER:					
		MATERIAL				SCALE: 1:16 WEIGHT:	
		FINISH				SHEET 1 OF 2	
	NEXT ASSY	USED ON					
		APPLICATION	DO NOT SCALE DRAWING				

2

1

B

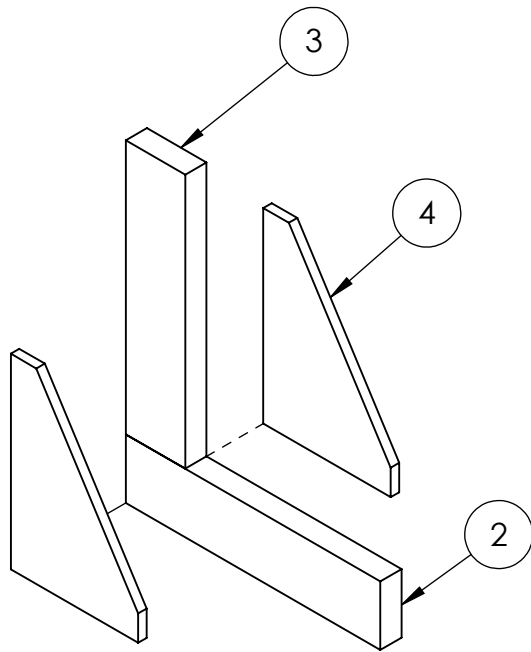

Create leg assemblies by attaching Item 4 (qty. 2) to Items 2 and 3 with wood screws as necessary. Qty. 2.

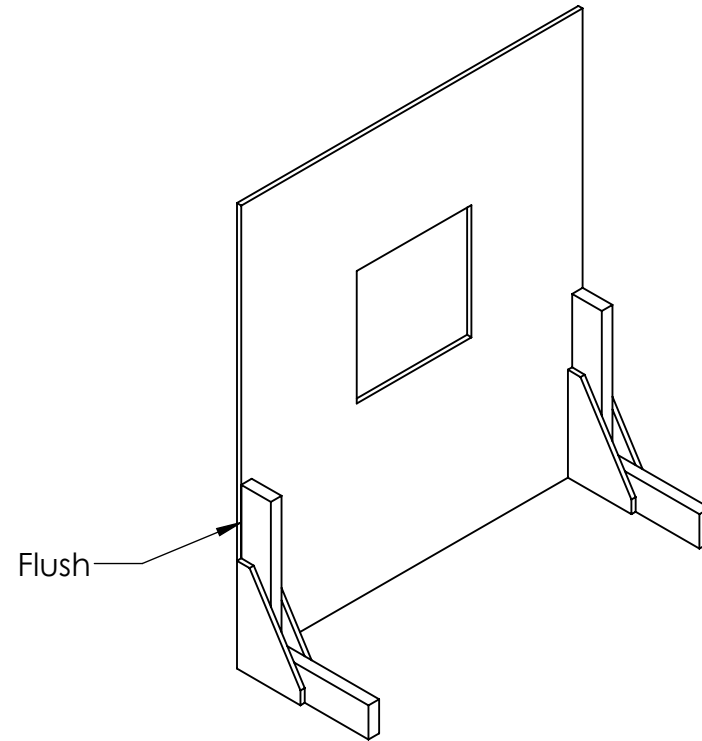



Attach two leg assemblies to Item 1 as shown using wood screws.

B

A

A

<p>PROPRIETARY AND CONFIDENTIAL THE INFORMATION CONTAINED IN THIS DRAWING IS THE SOLE PROPERTY OF FIRST®. Any REPRODUCTION IN PART OR AS A WHOLE WITHOUT THE WRITTEN PERMISSION OF FIRST® IS PROHIBITED.</p>			UNLESS OTHERWISE SPECIFIED:		NAME	DATE	 	
			DIMENSIONS ARE IN INCHES	DRAWN				<p>TITLE: Portal</p>
			TOLERANCES: FRACTIONAL $\pm 1/16$	CHECKED				
			ANGULAR: MACH $\pm 1^\circ$ BEND $\pm 1^\circ$	ENG APPR.				
			TWO PLACE DECIMAL $\pm .01$	MFG APPR.				
		THREE PLACE DECIMAL $\pm .001$	Q.A.					
		INTERPRET GEOMETRIC TOLERANCING PER:	COMMENTS:					
		MATERIAL					SIZE DWG. NO. REV	
	NEXT ASSY	USED ON	FINISH				A TE-18002	
	APPLICATION		DO NOT SCALE DRAWING				SCALE: 1:16 WEIGHT: SHEET 2 OF 2	

2

1

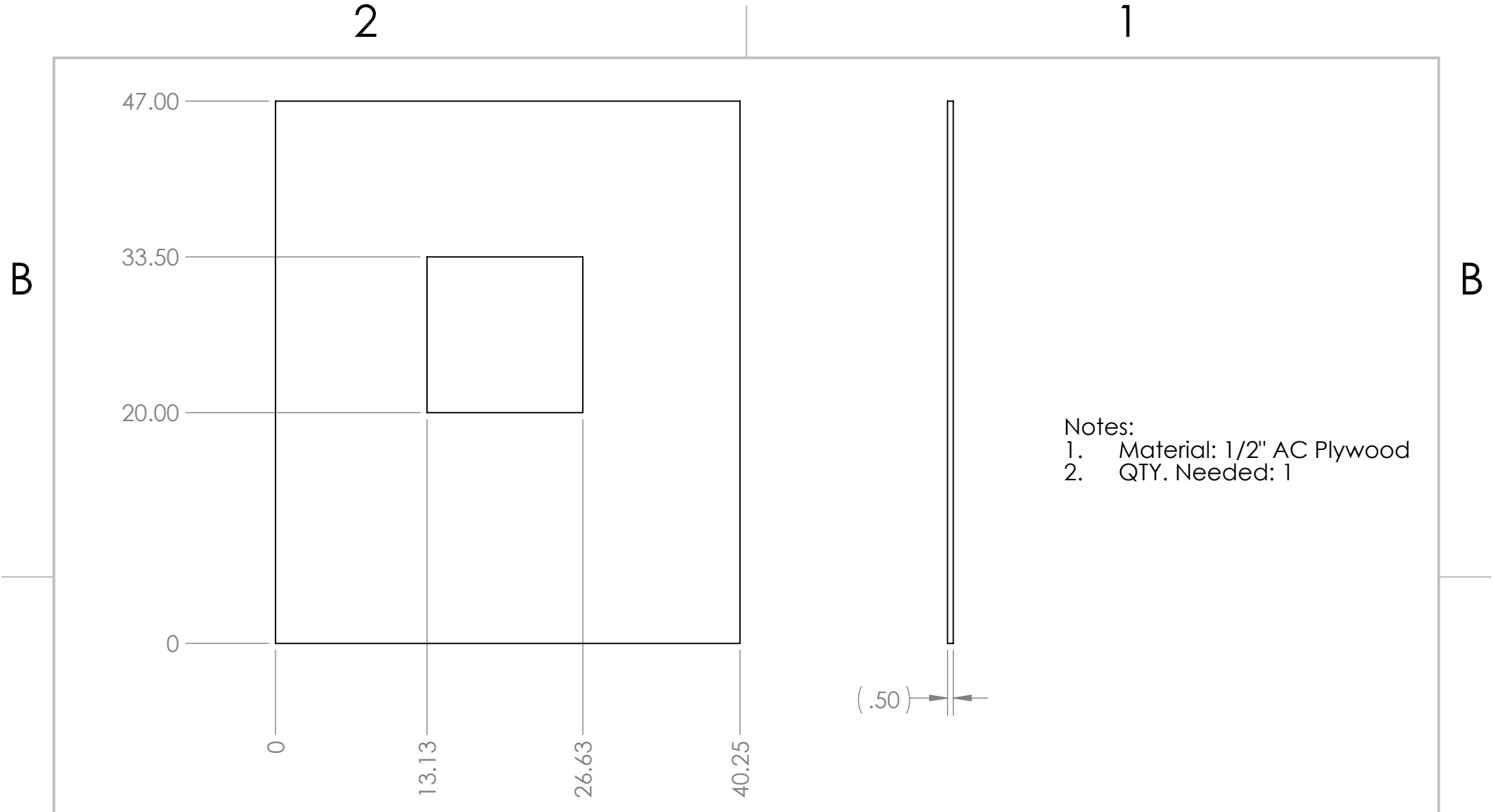

- Notes:
1. Material: 1/2" AC Plywood
 2. QTY. Needed: 1

A

A

PROPRIETARY AND CONFIDENTIAL
 THE INFORMATION CONTAINED IN THIS DRAWING IS THE SOLE PROPERTY OF **FIRST®**. ANY REPRODUCTION IN PART OR AS A WHOLE WITHOUT THE WRITTEN PERMISSION OF **FIRST®** IS PROHIBITED.

		UNLESS OTHERWISE SPECIFIED:		NAME	DATE
		DIMENSIONS ARE IN INCHES	DRAWN		
		TOLERANCES:	CHECKED		
		FRACTIONAL ± 1/16	ENG APPR.		
		ANGULAR: MACH ± 1° BEND ± 1°	MFG APPR.		
		TWO PLACE DECIMAL ± .01	Q.A.		
		THREE PLACE DECIMAL ± .001	COMMENTS:		
		INTERPRET GEOMETRIC TOLERANCING PER:			
		MATERIAL			
NEXT ASSY	USED ON	FINISH			
APPLICATION		DO NOT SCALE DRAWING			



TITLE:		
SIZE	DWG. NO.	REV
A	TE-18002-1	
SCALE: 1:12	WEIGHT:	SHEET 1 OF 1

2

1

2

1

B

B

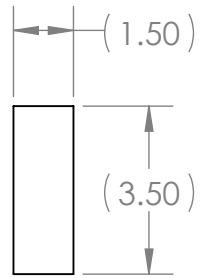
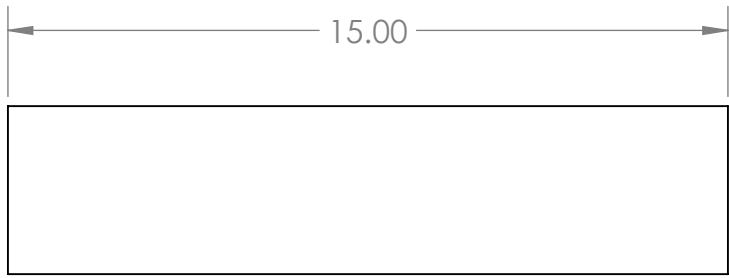

- Notes:
1. Material: 2" x 4" Pine Lumber
 2. QTY. Needed: 2

A

A

PROPRIETARY AND CONFIDENTIAL
 THE INFORMATION CONTAINED IN THIS DRAWING IS THE SOLE PROPERTY OF **FIRST®**. ANY REPRODUCTION IN PART OR AS A WHOLE WITHOUT THE WRITTEN PERMISSION OF **FIRST®** IS PROHIBITED.

		UNLESS OTHERWISE SPECIFIED:		NAME	DATE
		DIMENSIONS ARE IN INCHES	DRAWN		
		TOLERANCES:	CHECKED		
		FRACTIONAL ± 1/16	ENG APPR.		
		ANGULAR: MACH ± 1° BEND ± 1°	MFG APPR.		
		TWO PLACE DECIMAL ± .01	Q.A.		
		THREE PLACE DECIMAL ± .001	COMMENTS:		
		INTERPRET GEOMETRIC TOLERANCING PER:			
		MATERIAL			
	NEXT ASSY	FINISH			
		USED ON			
		APPLICATION			
		DO NOT SCALE DRAWING			



TITLE:		
SIZE	DWG. NO.	REV
A	TE-18002-2	
SCALE: 1:4	WEIGHT:	SHEET 1 OF 1

2

1

2

1

B

B

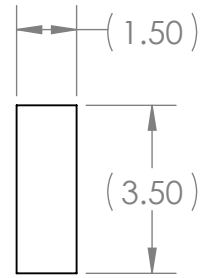
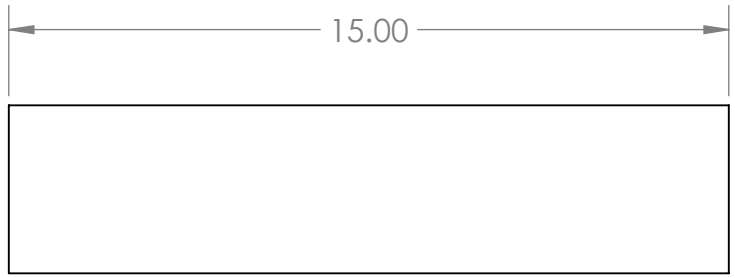

- Notes:
1. Material: 2" x 4" Pine Lumber
 2. QTY. Needed: 2

A

A

PROPRIETARY AND CONFIDENTIAL
 THE INFORMATION CONTAINED IN THIS DRAWING IS THE SOLE PROPERTY OF **FIRST®**. ANY REPRODUCTION IN PART OR AS A WHOLE WITHOUT THE WRITTEN PERMISSION OF **FIRST®** IS PROHIBITED.

		UNLESS OTHERWISE SPECIFIED:		NAME	DATE
		DIMENSIONS ARE IN INCHES	DRAWN		
		TOLERANCES:	CHECKED		
		FRACTIONAL ± 1/16	ENG APPR.		
		ANGULAR: MACH ± 1° BEND ± 1°	MFG APPR.		
		TWO PLACE DECIMAL ± .01	Q.A.		
		THREE PLACE DECIMAL ± .001	COMMENTS:		
		INTERPRET GEOMETRIC TOLERANCING PER:			
		MATERIAL			
		FINISH			
NEXT ASSY	USED ON				
APPLICATION		DO NOT SCALE DRAWING			



TITLE:		
SIZE	DWG. NO.	REV
A	TE-18002-3	
SCALE: 1:4	WEIGHT:	SHEET 1 OF 1

2

1

2

1

B

B

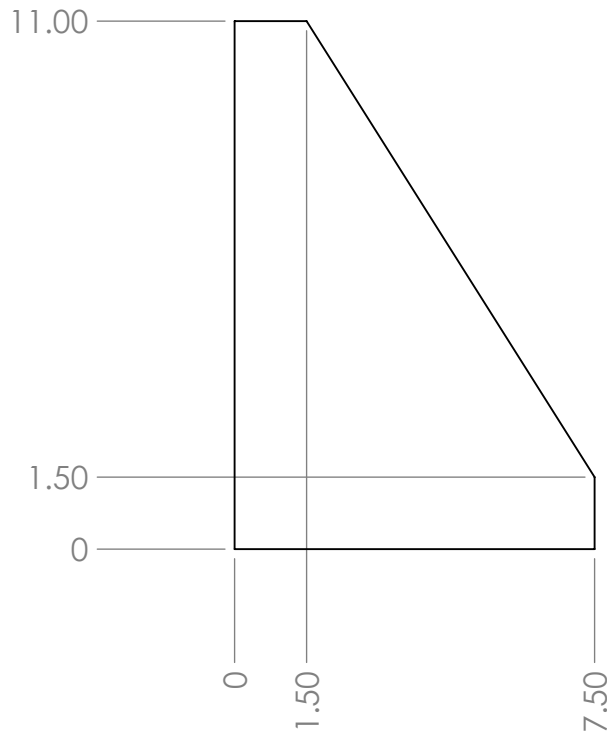
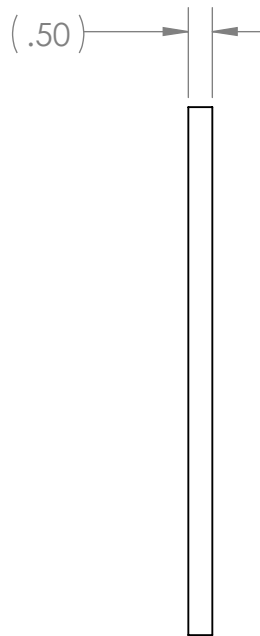

Notes:

- 1. Material: 1/2" AC Plywood
- 2. QTY. Needed: 4

A

A

		UNLESS OTHERWISE SPECIFIED:		NAME	DATE
		DIMENSIONS ARE IN INCHES	DRAWN		
		TOLERANCES:	CHECKED		
		FRACTIONAL ± 1/16	ENG APPR.		
		ANGULAR: MACH ± 1° BEND ± 1°	MFG APPR.		
		TWO PLACE DECIMAL ± .01	Q.A.		
		THREE PLACE DECIMAL ± .001	COMMENTS:		
		INTERPRET GEOMETRIC TOLERANCING PER:			
		MATERIAL			
		FINISH			
NEXT ASSY	USED ON				
APPLICATION		DO NOT SCALE DRAWING			



TITLE:		
SIZE	DWG. NO.	REV
A	TE-18002-4	
SCALE: 1:4	WEIGHT:	SHEET 1 OF 1

PROPRIETARY AND CONFIDENTIAL
 THE INFORMATION CONTAINED IN THIS DRAWING IS THE SOLE PROPERTY OF **FIRST®**. ANY REPRODUCTION IN PART OR AS A WHOLE WITHOUT THE WRITTEN PERMISSION OF **FIRST®** IS PROHIBITED.

2

1

4

3

2

1

B

B

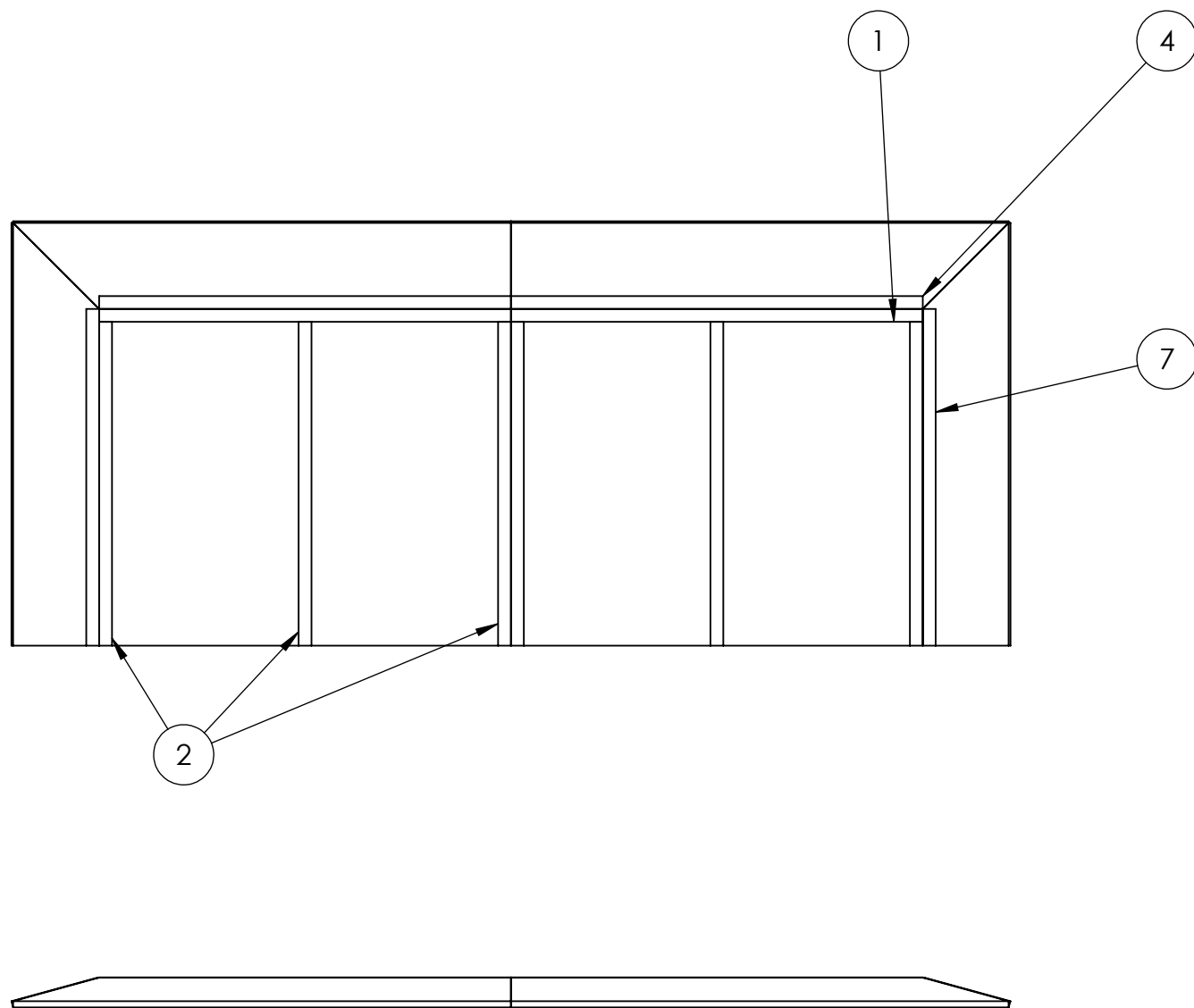

Note: The width of this platform varies from the field version to reduce cost. The top face of this platform is 96" wide, while the field version is 104".

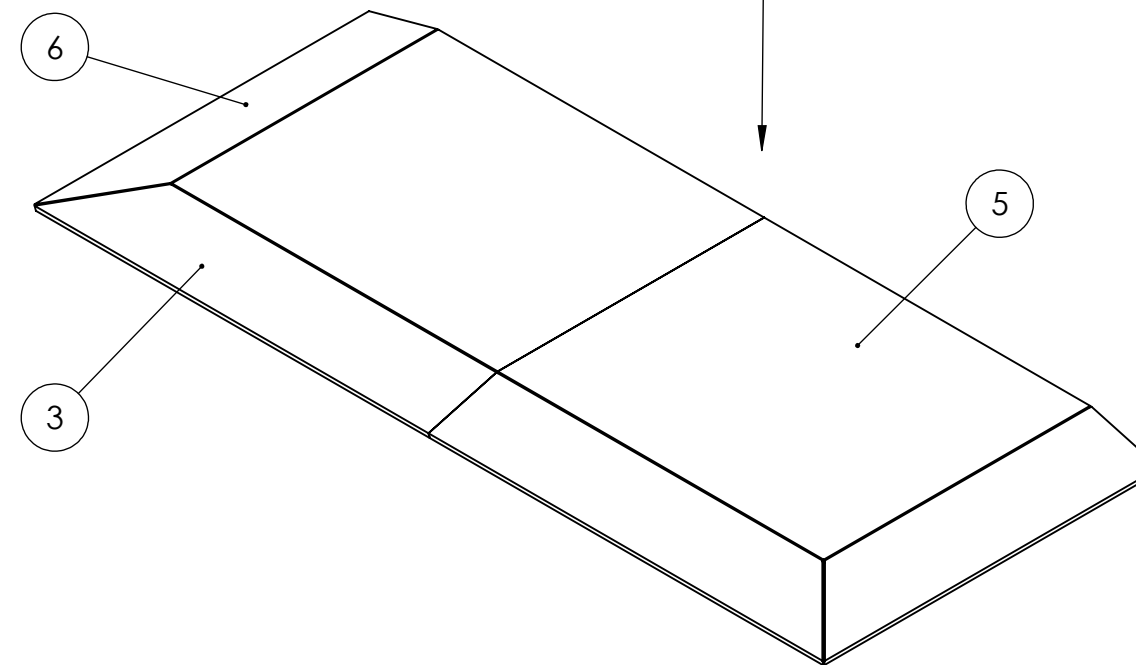



A

A

ITEM NO.	PART NUMBER	DESCRIPTION	QTY.
1	TE-18003-1		2
2	TE-18003-2		6
3	TE-18003-3		2
4	TE-18003-4		2
5	TE-18003-5		2
6	TE-18003-6		2
7	TE-18003-7		2

PROPRIETARY AND CONFIDENTIAL
 THE INFORMATION CONTAINED IN THIS DRAWING IS THE SOLE PROPERTY OF **FIRST®**. ANY REPRODUCTION IN PART OR AS A WHOLE WITHOUT THE WRITTEN PERMISSION OF **FIRST®** IS PROHIBITED.

		UNLESS OTHERWISE SPECIFIED:	NAME	DATE	 
		DIMENSIONS ARE IN INCHES TOLERANCES: FRACTIONAL $\pm 1/16$ ANGULAR: MACH $\pm 1^\circ$ BEND $\pm 1^\circ$ TWO PLACE DECIMAL $\pm .01$ THREE PLACE DECIMAL $\pm .001$	DRAWN		
		INTERPRET GEOMETRIC TOLERANCING PER:	CHECKED		SIZE DWG. NO. REV B TE-18003
		MATERIAL	ENG APPR.		
NEXT ASSY	USED ON	FINISH	MFG APPR.		
APPLICATION		DO NOT SCALE DRAWING	Q.A.		
			COMMENTS:		

4

3

2

1

4

3

2

1

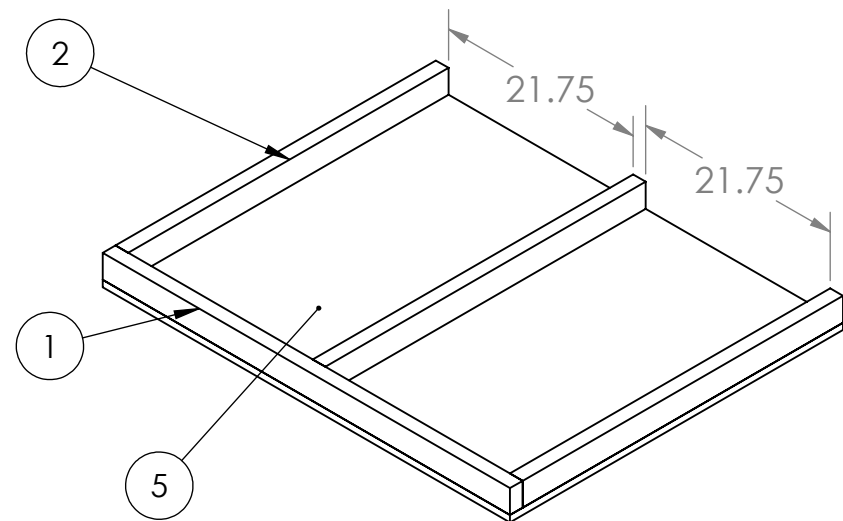

Step 1: Attach Item 1 and Item 2 (qty: 2) to Item 5 using wood screws. Build 2 identical assemblies.

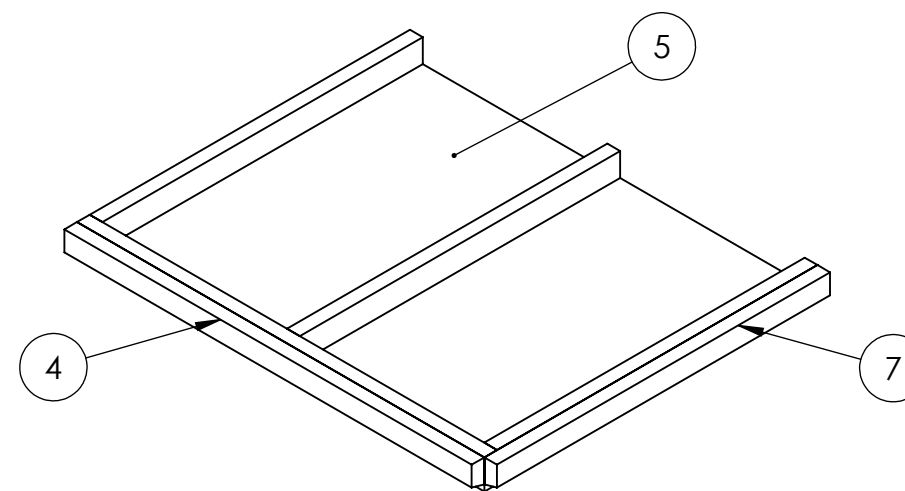

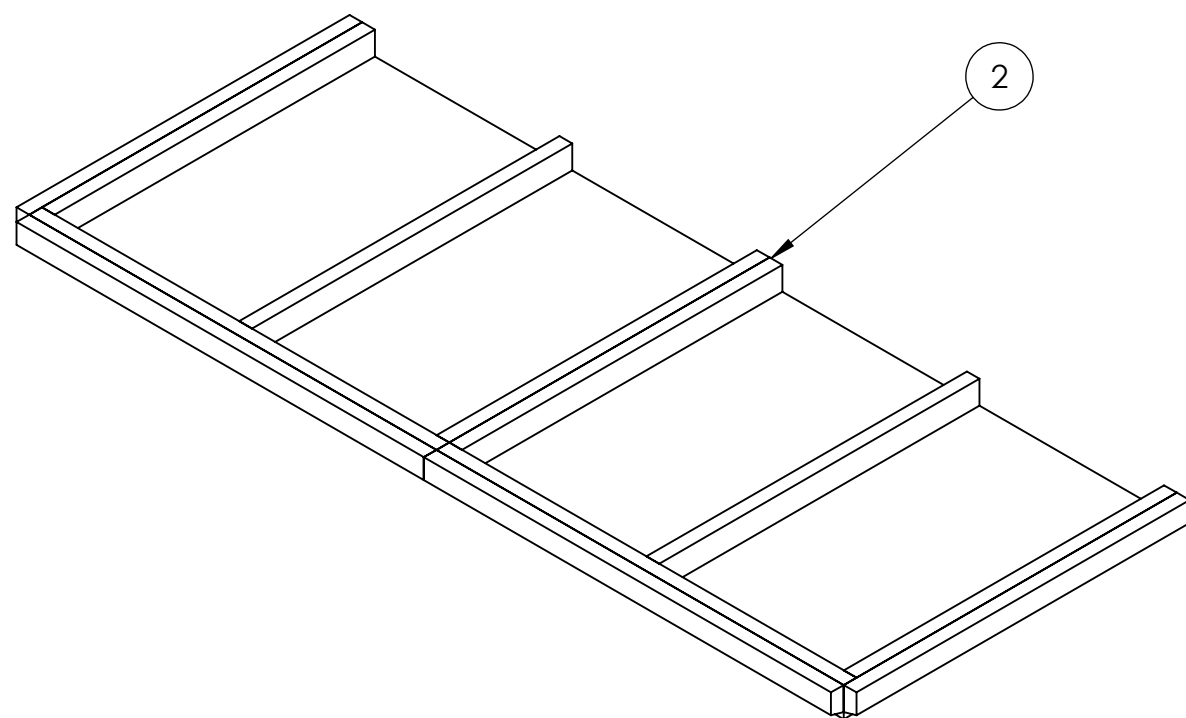

Step 2: Attach Item 4 and Item 7 to Item 5 using wood screws. Repeat for the second assembly.



Step 3: Use wood screws to attach the identical assemblies together, with Item 2 (qty: 2) in the middle.

PROPRIETARY AND CONFIDENTIAL
THE INFORMATION CONTAINED IN THIS DRAWING IS THE SOLE PROPERTY OF **FIRST®**. ANY REPRODUCTION IN PART OR AS A WHOLE WITHOUT THE WRITTEN PERMISSION OF **FIRST®** IS PROHIBITED.

		UNLESS OTHERWISE SPECIFIED:		NAME	DATE
		DIMENSIONS ARE IN INCHES TOLERANCES: FRACTIONAL: ±1/16 ANGULAR: MACH ±1° BEND ±1° TWO PLACE DECIMAL ±.01 THREE PLACE DECIMAL ±.001		DRAWN	
		INTERPRET GEOMETRIC TOLERANCING PER:		CHECKED	
		MATERIAL		ENG APPR.	
		FINISH		MFG APPR.	
NEXT ASSY	USED ON			Q.A.	
APPLICATION		DO NOT SCALE DRAWING		COMMENTS:	
				 	
				TITLE: Platform	
SIZE	DWG. NO.			REV	
B	TE-18003				
SCALE: 1:16				WEIGHT:	SHEET 2 OF 3

4

3

2

1

B

B

A

A

4

3

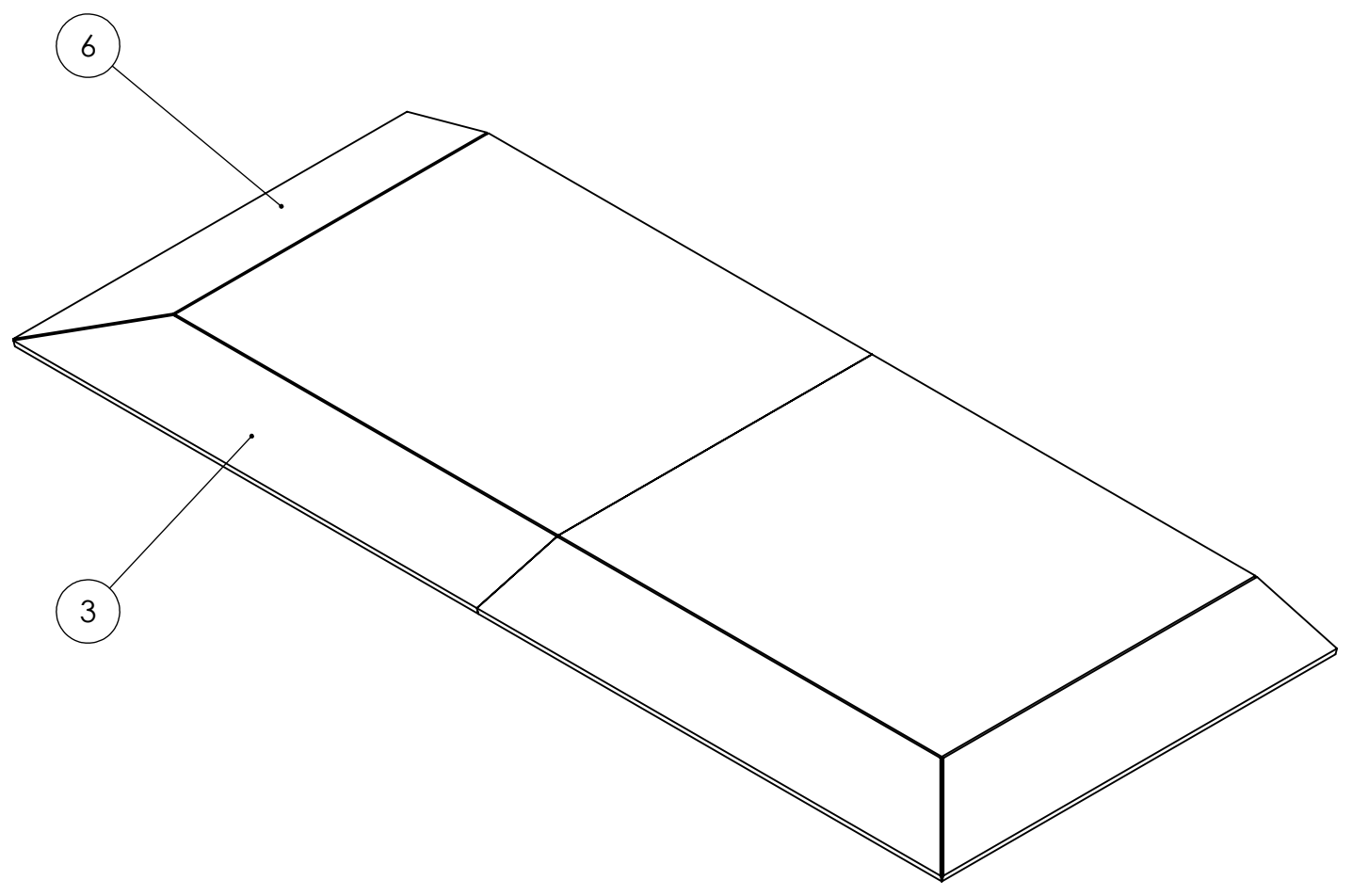

2

1



Step 4: Use wood screws to fasten Item 3 (qty: 2) to Item 4 (qty: 2), and Item 6 (qty: 2) to Item 7 (qty: 2).

PROPRIETARY AND CONFIDENTIAL
 THE INFORMATION CONTAINED IN THIS DRAWING IS THE SOLE PROPERTY OF **FIRST®**. ANY REPRODUCTION IN PART OR AS A WHOLE WITHOUT THE WRITTEN PERMISSION OF **FIRST®** IS PROHIBITED.

		UNLESS OTHERWISE SPECIFIED:	NAME	DATE	 
		DIMENSIONS ARE IN INCHES TOLERANCES: FRACTIONAL ±1/16 ANGULAR: MACH ±1° BEND ±1° TWO PLACE DECIMAL ±.01 THREE PLACE DECIMAL ±.001	DRAWN		
		INTERPRET GEOMETRIC TOLERANCING PER:	CHECKED		SIZE B DWG. NO. TE-18003 REV SCALE: 1:16 WEIGHT: SHEET 3 OF 3
		MATERIAL	ENG APPR.		
NEXT ASSY	USED ON	FINISH	MFG APPR.		
APPLICATION		DO NOT SCALE DRAWING	Q.A.		
			COMMENTS:		

4

3

2

1

B

B

A

A

2

1

B

B

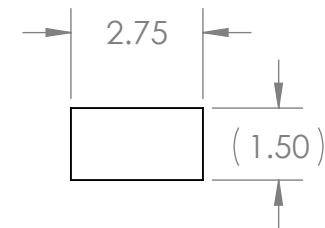
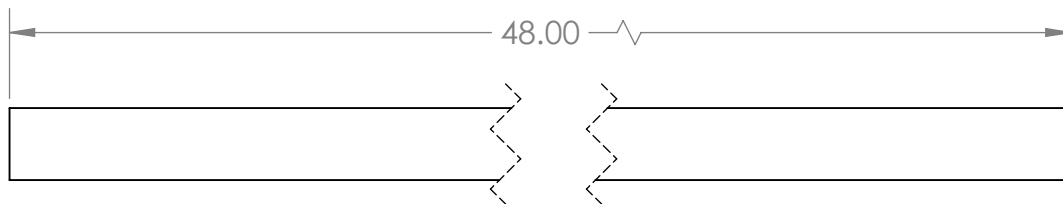

Notes:

- 1. Material: 2" x 4" Pine Lumber
- 2. QTY. Needed: 2

A

A

PROPRIETARY AND CONFIDENTIAL
 THE INFORMATION CONTAINED IN THIS DRAWING IS THE SOLE PROPERTY OF **FIRST®**. ANY REPRODUCTION IN PART OR AS A WHOLE WITHOUT THE WRITTEN PERMISSION OF **FIRST®** IS PROHIBITED.

		UNLESS OTHERWISE SPECIFIED:		NAME	DATE
		DIMENSIONS ARE IN INCHES	DRAWN		
		TOLERANCES:	CHECKED		
		FRACTIONAL ± 1/16	ENG APPR.		
		ANGULAR: MACH ± 1° BEND ± 1°	MFG APPR.		
		TWO PLACE DECIMAL ± .01	Q.A.		
		THREE PLACE DECIMAL ± .001	COMMENTS:		
		INTERPRET GEOMETRIC TOLERANCING PER:			
		MATERIAL			
		FINISH			
NEXT ASSY	USED ON				
APPLICATION		DO NOT SCALE DRAWING			



TITLE:		
SIZE	DWG. NO.	REV
A	TE-18003-1	
SCALE: 1:4	WEIGHT:	SHEET 1 OF 1

2

1

2

1

B

B

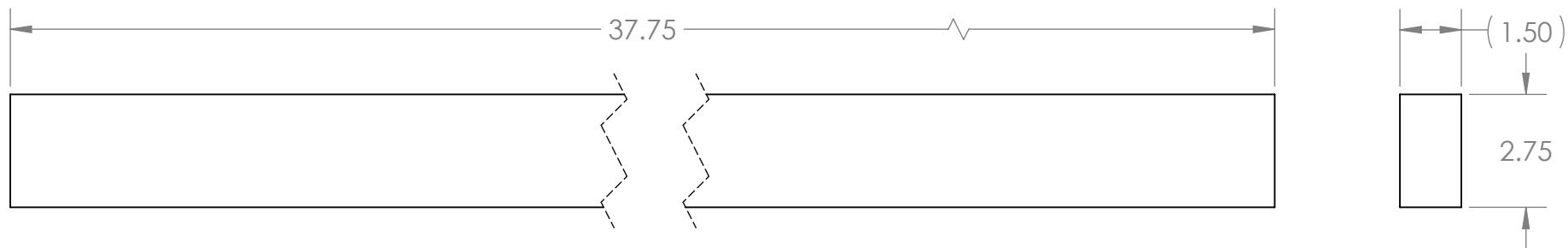

Notes:

- 1. Material: 2" x 4" Pine Lumber
- 2. QTY. Needed: 6

A

A

PROPRIETARY AND CONFIDENTIAL
 THE INFORMATION CONTAINED IN THIS DRAWING IS THE SOLE PROPERTY OF **FIRST®**. ANY REPRODUCTION IN PART OR AS A WHOLE WITHOUT THE WRITTEN PERMISSION OF **FIRST®** IS PROHIBITED.

		UNLESS OTHERWISE SPECIFIED:		NAME	DATE
		DIMENSIONS ARE IN INCHES	DRAWN		
		TOLERANCES:	CHECKED		
		FRACTIONAL ± 1/16	ENG APPR.		
		ANGULAR: MACH ± 1° BEND ± 1°	MFG APPR.		
		TWO PLACE DECIMAL ± .01	Q.A.		
		THREE PLACE DECIMAL ± .001	COMMENTS:		
		INTERPRET GEOMETRIC TOLERANCING PER:			
		MATERIAL			
		FINISH			
NEXT ASSY	USED ON				
APPLICATION		DO NOT SCALE DRAWING			



TITLE:		
SIZE	DWG. NO.	REV
A	TE-18003-2	
SCALE: 1:4	WEIGHT:	SHEET 1 OF 1

2

1

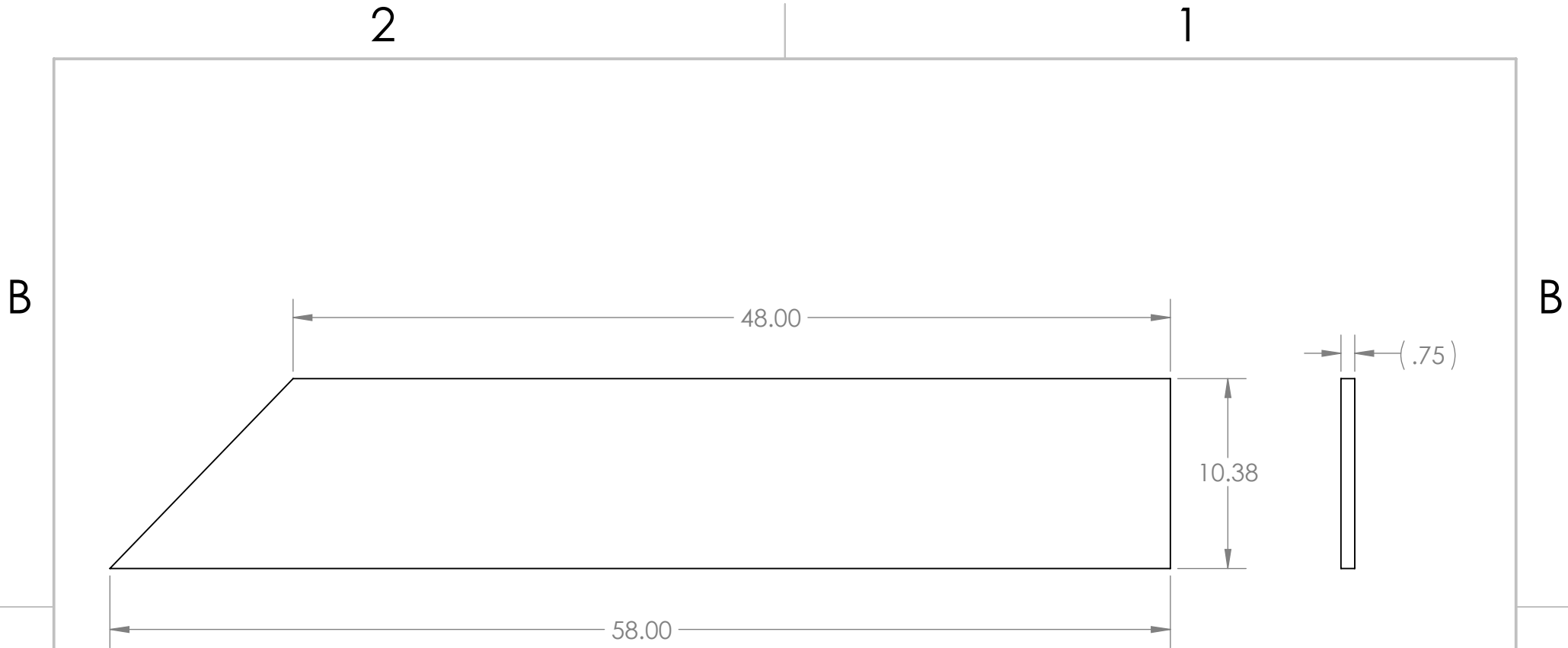

Notes:

1. Material: 3/4" AC Plywood
2. QTY. Needed: 2

PROPRIETARY AND CONFIDENTIAL
 THE INFORMATION CONTAINED IN THIS DRAWING IS THE SOLE PROPERTY OF **FIRST®**. ANY REPRODUCTION IN PART OR AS A WHOLE WITHOUT THE WRITTEN PERMISSION OF **FIRST®** IS PROHIBITED.

		UNLESS OTHERWISE SPECIFIED:	NAME	DATE
		DIMENSIONS ARE IN INCHES	DRAWN	
		TOLERANCES:	CHECKED	
		FRACTIONAL $\pm 1/16$	ENG APPR.	
		ANGULAR: MACH $\pm 1^\circ$ BEND $\pm 1^\circ$	MFG APPR.	
		TWO PLACE DECIMAL $\pm .01$	Q.A.	
		THREE PLACE DECIMAL $\pm .001$	COMMENTS:	
		INTERPRET GEOMETRIC TOLERANCING PER:		
		MATERIAL		
NEXT ASSY	USED ON	FINISH		
APPLICATION		DO NOT SCALE DRAWING		



TITLE:		
SIZE	DWG. NO.	REV
A	TE-18003-3	
SCALE: 1:8	WEIGHT:	SHEET 1 OF 1

2

1

B

B

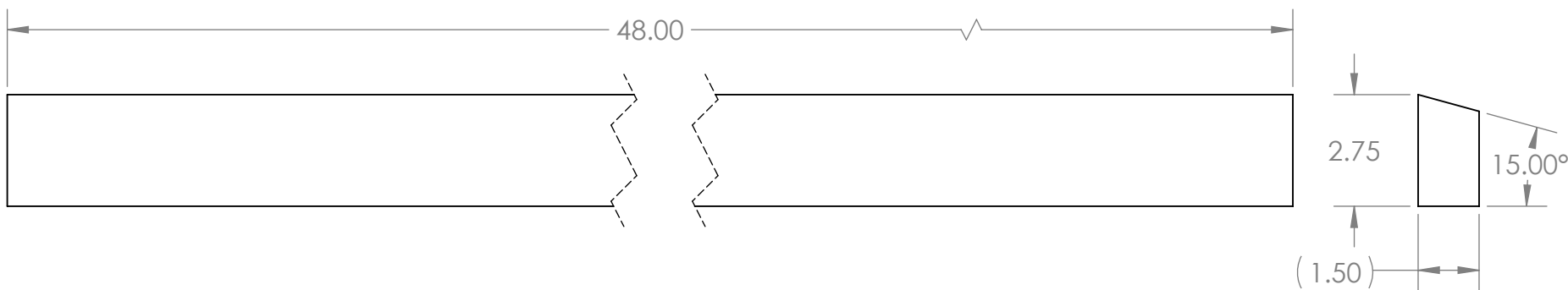

- Notes:
1. Material: 2" x 4" Pine Lumber
 2. QTY. Needed: 2

A

A

PROPRIETARY AND CONFIDENTIAL
 THE INFORMATION CONTAINED IN THIS DRAWING IS THE SOLE PROPERTY OF **FIRST®**. ANY REPRODUCTION IN PART OR AS A WHOLE WITHOUT THE WRITTEN PERMISSION OF **FIRST®** IS PROHIBITED.

		UNLESS OTHERWISE SPECIFIED:		NAME	DATE
		DIMENSIONS ARE IN INCHES	DRAWN		
		TOLERANCES:	CHECKED		
		FRACTIONAL ± 1/16	ENG APPR.		
		ANGULAR: MACH ± 1° BEND ± 1°	MFG APPR.		
		TWO PLACE DECIMAL ± .01	Q.A.		
		THREE PLACE DECIMAL ± .001	COMMENTS:		
		INTERPRET GEOMETRIC TOLERANCING PER:			
		MATERIAL			
		FINISH			
NEXT ASSY	USED ON				
APPLICATION		DO NOT SCALE DRAWING			



TITLE:		
SIZE	DWG. NO.	REV
A	TE-18003-4	
SCALE: 1:4	WEIGHT:	SHEET 1 OF 1

2

1

2

1

B

B

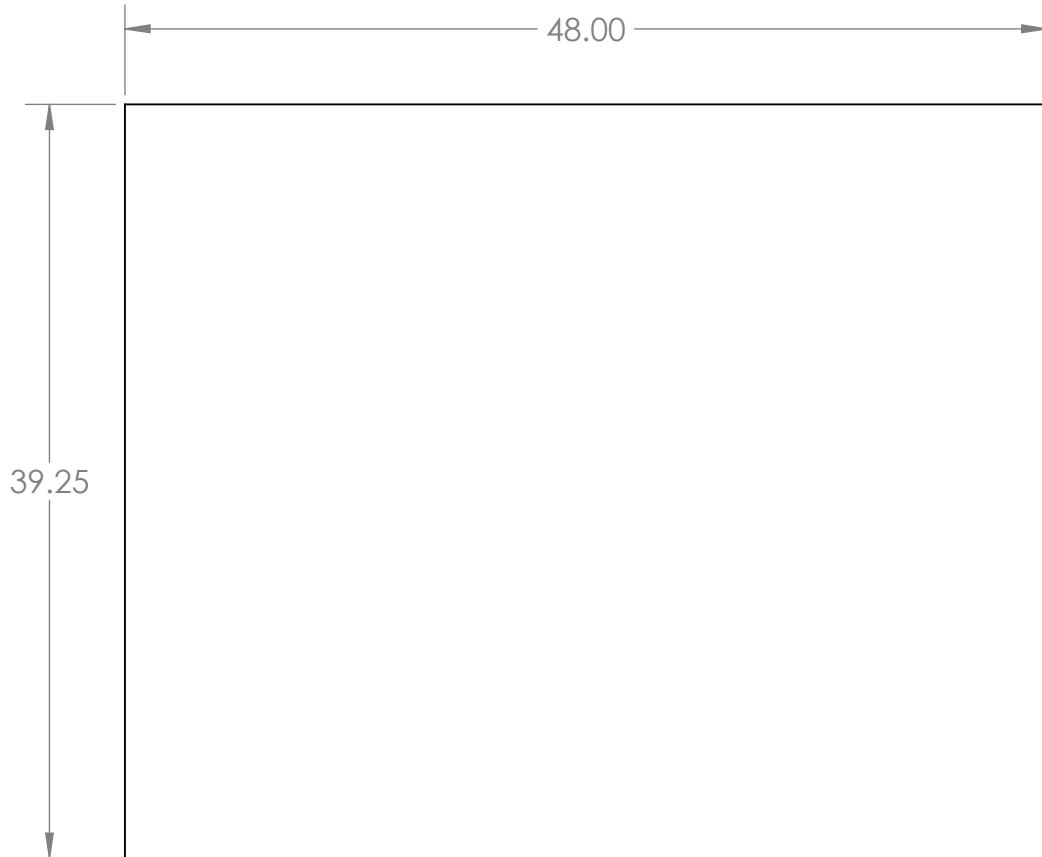

Notes:



- 1. Material: 3/4" AC Plywood
- 2. QTY. Needed: 2

A

A

PROPRIETARY AND CONFIDENTIAL
 THE INFORMATION CONTAINED IN THIS DRAWING IS THE SOLE PROPERTY OF **FIRST®**. ANY REPRODUCTION IN PART OR AS A WHOLE WITHOUT THE WRITTEN PERMISSION OF **FIRST®** IS PROHIBITED.

		UNLESS OTHERWISE SPECIFIED:		NAME	DATE
		DIMENSIONS ARE IN INCHES	DRAWN		
		TOLERANCES:	CHECKED		
		FRACTIONAL ± 1/16	ENG APPR.		
		ANGULAR: MACH ± 1° BEND ± 1°	MFG APPR.		
		TWO PLACE DECIMAL ± .01	Q.A.		
		THREE PLACE DECIMAL ± .001	COMMENTS:		
		INTERPRET GEOMETRIC TOLERANCING PER:			
		MATERIAL			
		FINISH			
NEXT ASSY	USED ON				
APPLICATION		DO NOT SCALE DRAWING			





TITLE:

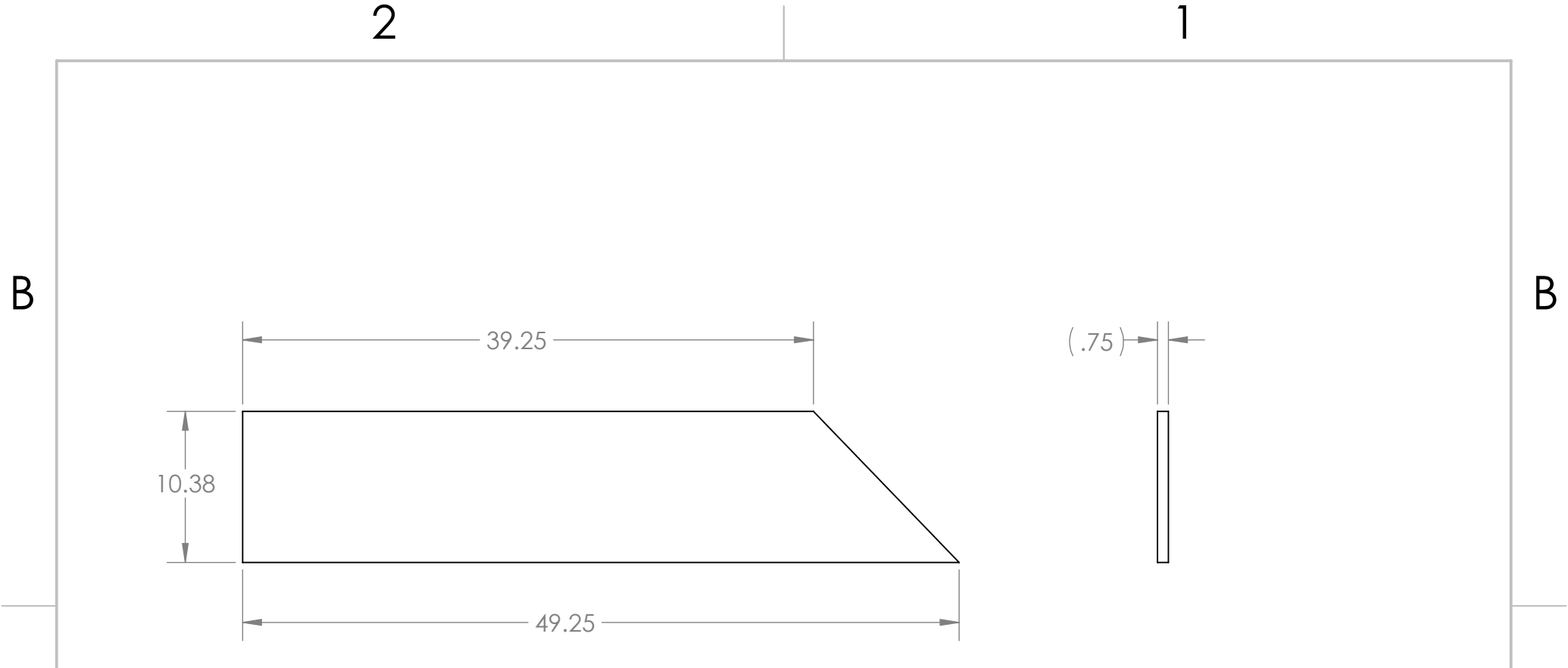

SIZE	DWG. NO.	REV
A	TE-18003-5	
SCALE: 1:10	WEIGHT:	SHEET 1 OF 1

2

1



- Notes:
1. Material: 3/4" AC Plywood
 2. QTY. Needed: 2

<p>PROPRIETARY AND CONFIDENTIAL</p> <p>THE INFORMATION CONTAINED IN THIS DRAWING IS THE SOLE PROPERTY OF FIRST®. ANY REPRODUCTION IN PART OR AS A WHOLE WITHOUT THE WRITTEN PERMISSION OF FIRST® IS PROHIBITED.</p>			UNLESS OTHERWISE SPECIFIED:		NAME	DATE	 		
			DIMENSIONS ARE IN INCHES	DRAWN				TITLE:	
			TOLERANCES:	CHECKED					
			FRACTIONAL $\pm 1/16$	ENG APPR.					
			ANGULAR: MACH $\pm 1^\circ$ BEND $\pm 1^\circ$	MFG APPR.					
		TWO PLACE DECIMAL $\pm .01$	Q.A.						
		THREE PLACE DECIMAL $\pm .001$	COMMENTS:						
		INTERPRET GEOMETRIC TOLERANCING PER:	MATERIAL				SIZE	DWG. NO.	REV
	NEXT ASSY	USED ON	FINISH				A	TE-18003-6	
	APPLICATION		DO NOT SCALE DRAWING				SCALE: 1:10	WEIGHT:	SHEET 1 OF 1

A

A

2

1

2

1

B

B

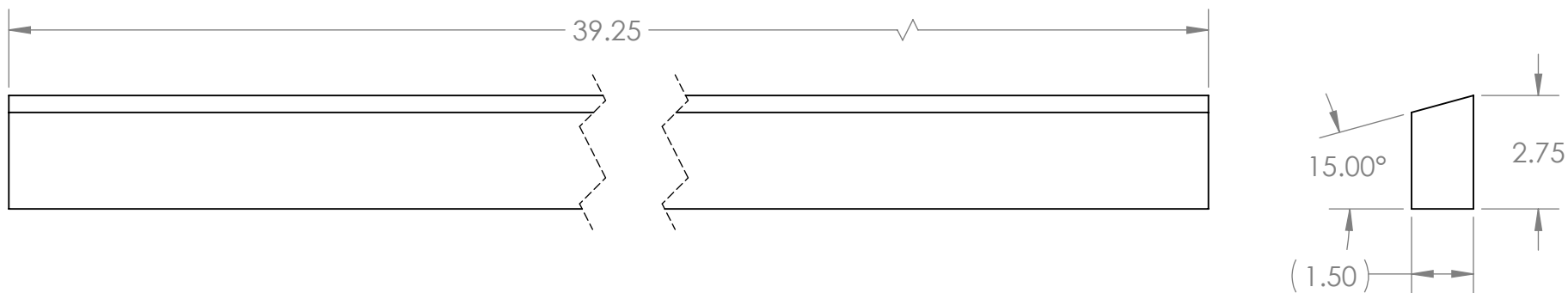

Notes:

1. Material: 2" x 4" Pine Lumber
2. QTY. Needed: 2

A

A

PROPRIETARY AND CONFIDENTIAL
 THE INFORMATION CONTAINED IN THIS DRAWING IS THE SOLE PROPERTY OF **FIRST®**. ANY REPRODUCTION IN PART OR AS A WHOLE WITHOUT THE WRITTEN PERMISSION OF **FIRST®** IS PROHIBITED.

		UNLESS OTHERWISE SPECIFIED:		NAME	DATE
		DIMENSIONS ARE IN INCHES	DRAWN		
		TOLERANCES:	CHECKED		
		FRACTIONAL ± 1/16	ENG APPR.		
		ANGULAR: MACH ± 1° BEND ± 1°	MFG APPR.		
		TWO PLACE DECIMAL ± .01	Q.A.		
		THREE PLACE DECIMAL ± .001	COMMENTS:		
		INTERPRET GEOMETRIC TOLERANCING PER:			
		MATERIAL			
		FINISH			
NEXT ASSY	USED ON				
APPLICATION		DO NOT SCALE DRAWING			



TITLE:		
SIZE	DWG. NO.	REV
A	TE-18003-7	
SCALE: 1:4	WEIGHT:	SHEET 1 OF 1

2

1

4

3

2

1

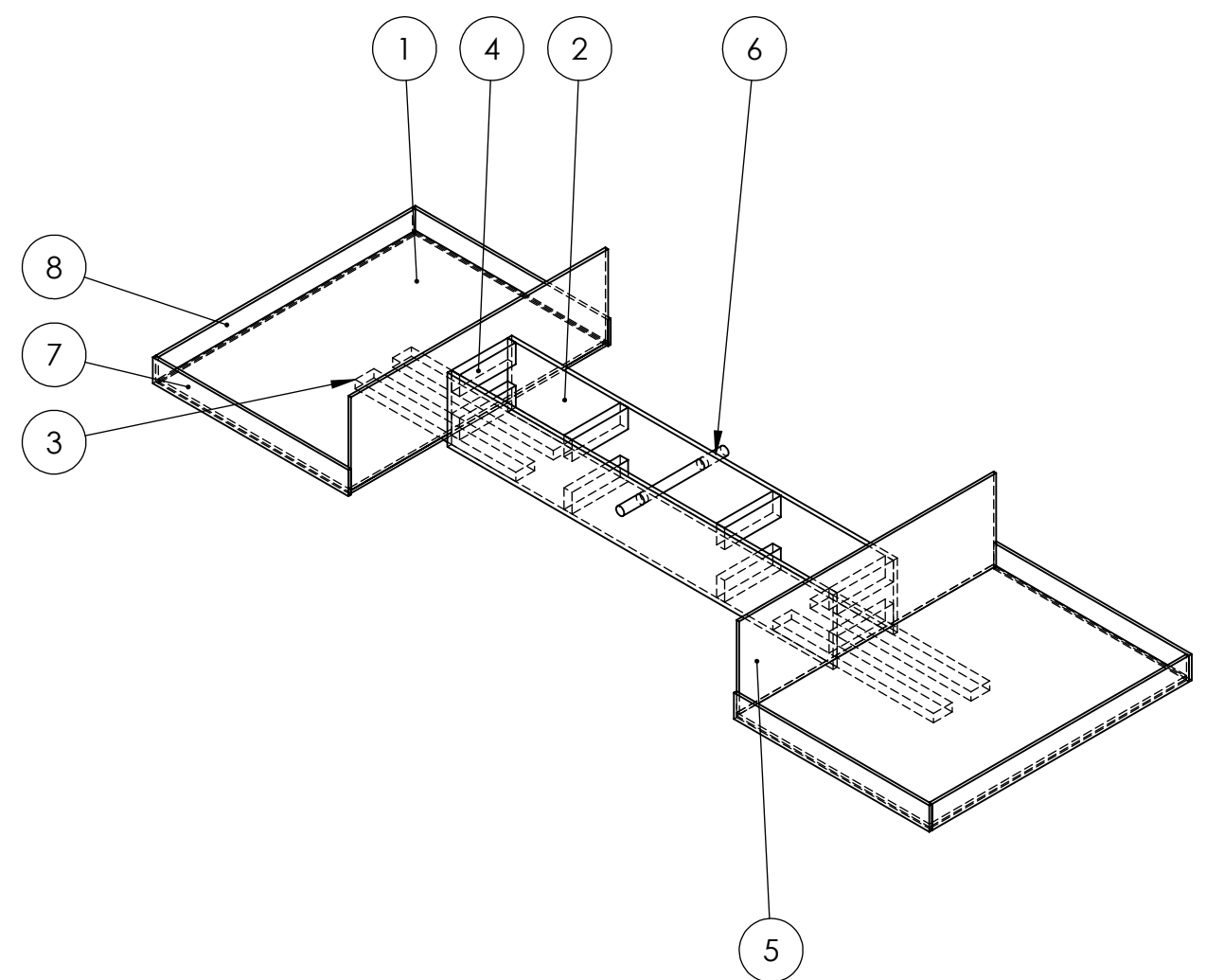

ITEM NO.	PART NUMBER	DESCRIPTION	QTY.
1	TE-18004-01		2
2	TE-18004-02		2
3	TE-18004-03		4
4	TE-18004-04		8
5	TE-18004-05		2
6	TE-18004-06		1
7	TE-18004-07		4
8	TE-18004-08		2

PROPRIETARY AND CONFIDENTIAL
 THE INFORMATION CONTAINED IN THIS DRAWING IS THE SOLE PROPERTY OF **FIRST**®. ANY REPRODUCTION IN PART OR AS A WHOLE WITHOUT THE WRITTEN PERMISSION OF **FIRST**® IS PROHIBITED.

UNLESS OTHERWISE SPECIFIED:		NAME	DATE
DIMENSIONS ARE IN INCHES		DRAWN	
TOLERANCES:		CHECKED	
FRACTIONAL ±1/16		ENG APPR.	
ANGULAR: MACH ±1° BEND ±1°		MFG APPR.	
TWO PLACE DECIMAL ±.01		Q.A.	
THREE PLACE DECIMAL ±.001		COMMENTS:	
INTERPRET GEOMETRIC TOLERANCING PER:		TITLE: Switch Arm	
MATERIAL		SIZE	DWG. NO.
FINISH		B	TE-18004
NEXT ASSY	USED ON	REV	
APPLICATION	DO NOT SCALE DRAWING	SCALE: 1:24	WEIGHT: SHEET 1 OF 3



4

3

2

1

B

B

A

A

4

3

2

1

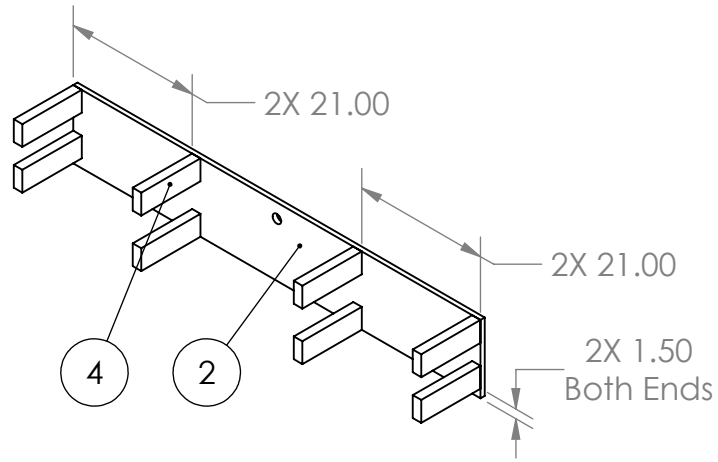

Step 1: Attach Item 4 (qty. 8) to Item 2 as shown with wood screws.

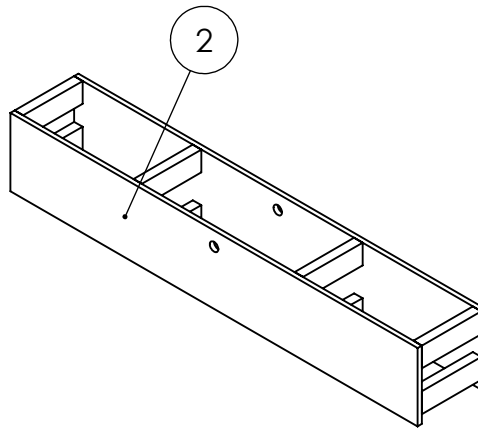

Step 2: Attach Item 2 to assembly as shown with wood screws.

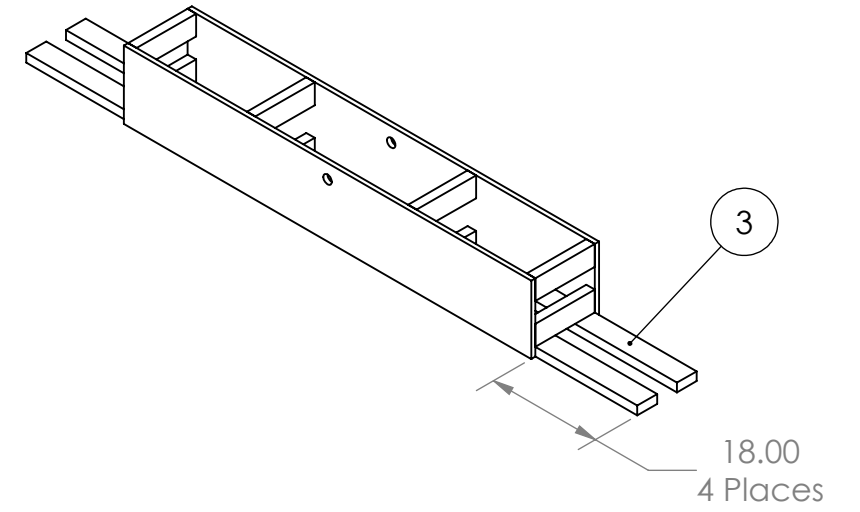

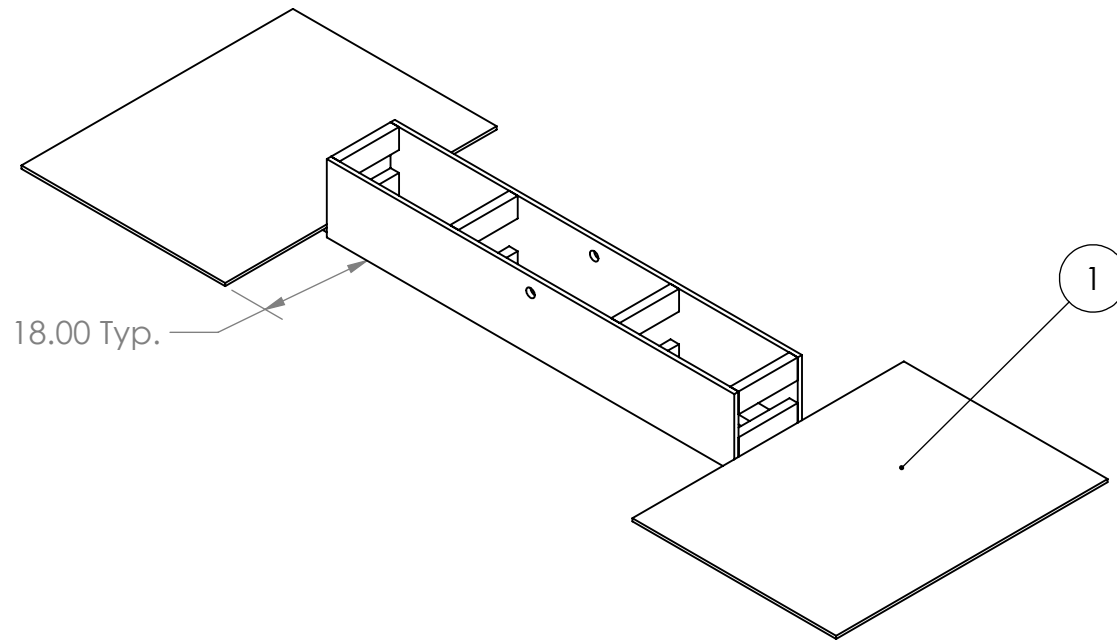

Step 3: Attach Item 3 (qty. 4) to assembly as shown with wood screws.



Step 4: Attach Item 1 (qty. 2) to assembly as shown with wood screws.

PROPRIETARY AND CONFIDENTIAL
THE INFORMATION CONTAINED IN THIS DRAWING IS THE SOLE PROPERTY OF **FIRST®**. ANY REPRODUCTION IN PART OR AS A WHOLE WITHOUT THE WRITTEN PERMISSION OF **FIRST®** IS PROHIBITED.

		UNLESS OTHERWISE SPECIFIED:		NAME	DATE
		DIMENSIONS ARE IN INCHES		DRAWN	
		TOLERANCES:		CHECKED	
		FRACTIONAL: ±1/16		ENG APPR.	
		ANGULAR: MACH ±1° BEND ±1°		MFG APPR.	
		TWO PLACE DECIMAL ±.01		Q.A.	
		THREE PLACE DECIMAL ±.001		COMMENTS:	
		INTERPRET GEOMETRIC TOLERANCING PER:			
		MATERIAL			
		FINISH			
NEXT ASSY	USED ON				
APPLICATION		DO NOT SCALE DRAWING			

TITLE:

Switch Arm

SIZE	DWG. NO.	REV
B	TE-18004	
SCALE: 1:24 WEIGHT:		SHEET 2 OF 3

4

3

2

1

4

3

2

1

B

B

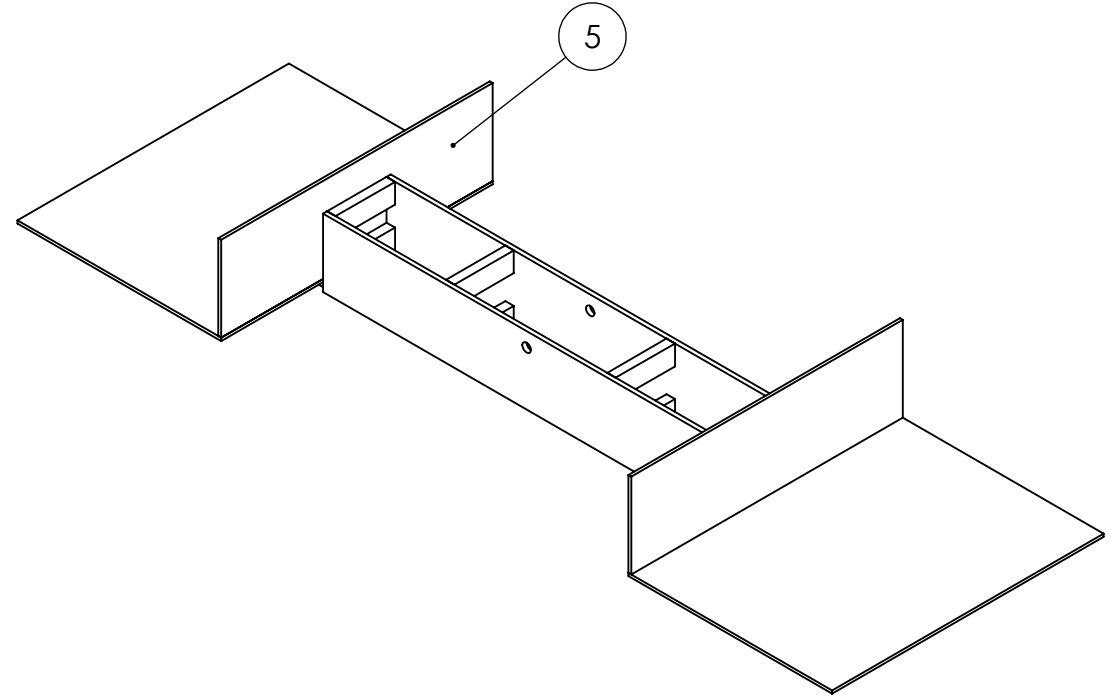

Step 5: Attach Item 5 (qty. 2) to assembly as shown with wood screws.

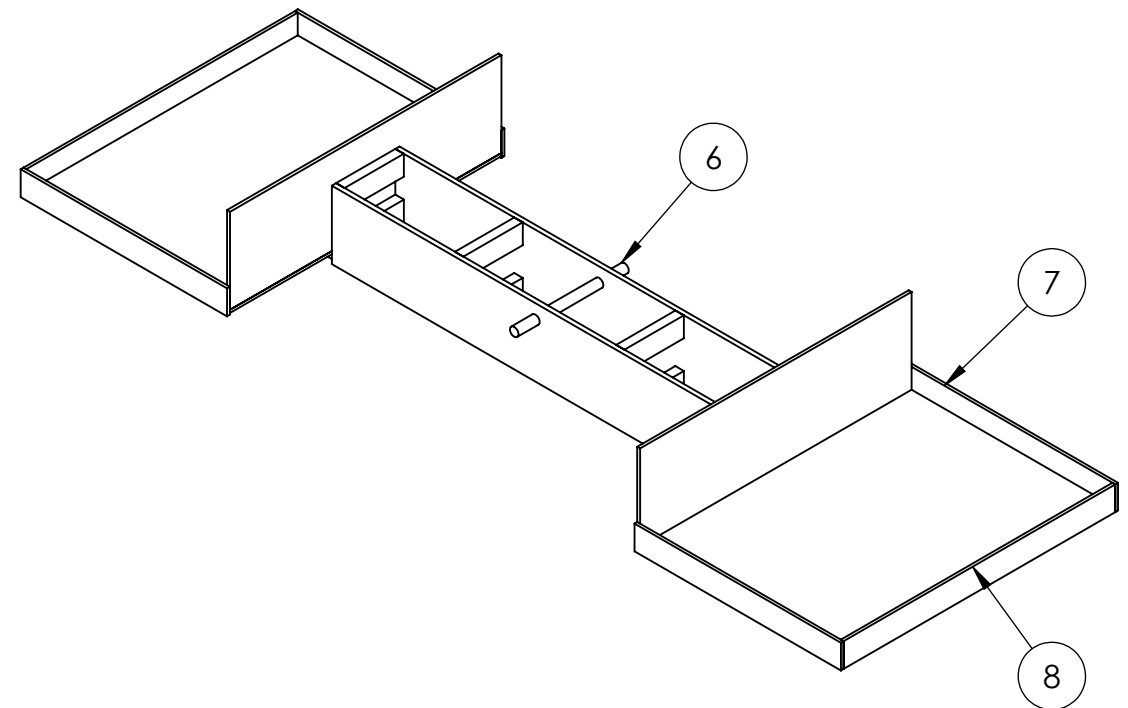

Step 6: Attach Item 7 (qty. 4) and Item 8 (qty. 2) to Item 2 as shown with wood screws or staples. When using screws, pre-drill to avoid splitting.



Place Item 6 as shown, but do not attach.

A

A

PROPRIETARY AND CONFIDENTIAL
 THE INFORMATION CONTAINED IN THIS DRAWING IS THE SOLE PROPERTY OF **FIRST®**. ANY REPRODUCTION IN PART OR AS A WHOLE WITHOUT THE WRITTEN PERMISSION OF **FIRST®** IS PROHIBITED.

		UNLESS OTHERWISE SPECIFIED:		NAME	DATE
		DIMENSIONS ARE IN INCHES		DRAWN	
		TOLERANCES:		CHECKED	
		FRACTIONAL ±1/16		ENG APPR.	
		ANGULAR: MACH ±1° BEND ±1°		MFG APPR.	
		TWO PLACE DECIMAL ±.01		Q.A.	
		THREE PLACE DECIMAL ±.001		COMMENTS:	
		INTERPRET GEOMETRIC TOLERANCING PER:			
		MATERIAL			
		FINISH			
NEXT ASSY	USED ON				
APPLICATION		DO NOT SCALE DRAWING			

TITLE:

Switch Arm

SIZE	DWG. NO.	REV
B	TE-18004	
SCALE: 1:24	WEIGHT:	SHEET 3 OF 3

4

3

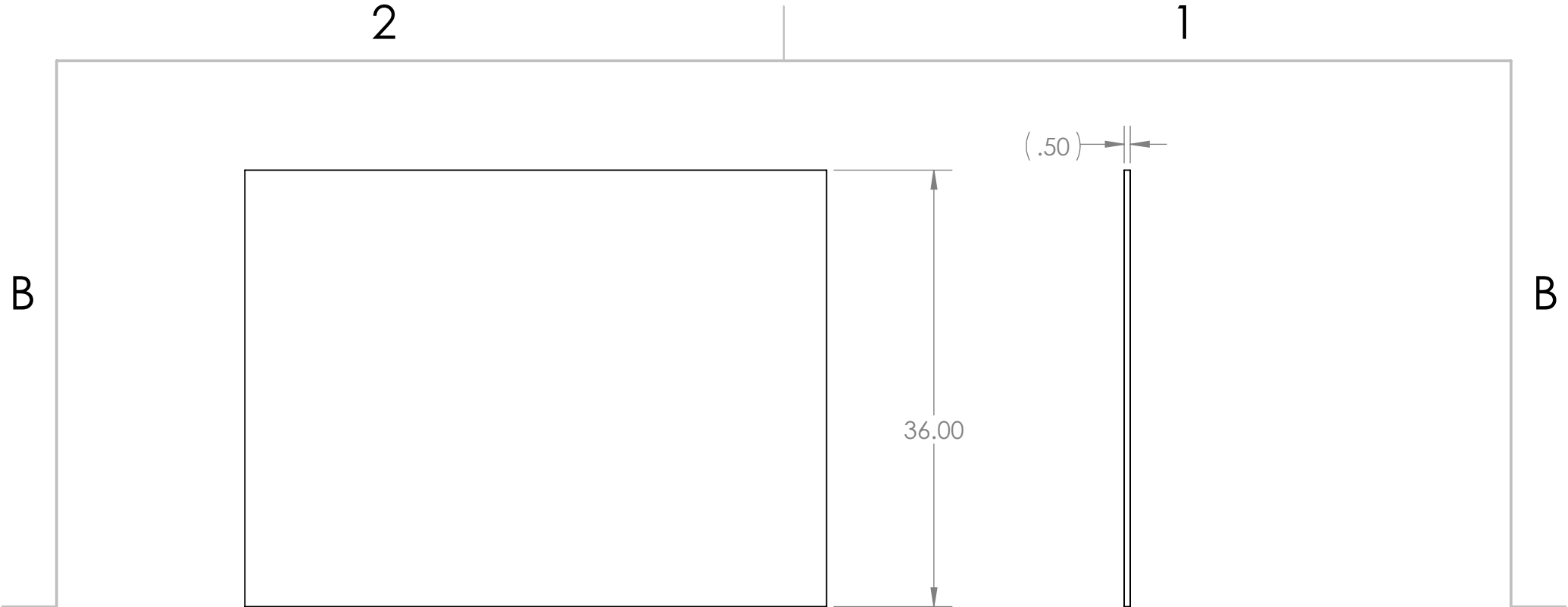

2

1



NOTES:

1. Material: 1/2" AC Plywood
2. QTY. Needed: 2

<p>PROPRIETARY AND CONFIDENTIAL THE INFORMATION CONTAINED IN THIS DRAWING IS THE SOLE PROPERTY OF FIRST®. Any REPRODUCTION IN PART OR AS A WHOLE WITHOUT THE WRITTEN PERMISSION OF FIRST® IS PROHIBITED.</p>			UNLESS OTHERWISE SPECIFIED:		NAME	DATE	 						
			DIMENSIONS ARE IN INCHES TOLERANCES: FRACTIONAL $\pm 1/16$ ANGULAR: MACH $\pm 1^\circ$ BEND $\pm 1^\circ$ TWO PLACE DECIMAL $\pm .01$ THREE PLACE DECIMAL $\pm .001$	DRAWN				TITLE:					
			INTERPRET GEOMETRIC TOLERANCING PER:	CHECKED									
			MATERIAL .5 Ply	ENG APPR.									
			FINISH	MFG APPR.									
	NEXT ASSY	USED ON	DO NOT SCALE DRAWING	COMMENTS:			<table border="1"> <tr> <td>SIZE</td> <td>DWG. NO.</td> <td>REV</td> </tr> <tr> <td>A</td> <td>TE-18004-01</td> <td></td> </tr> </table>	SIZE	DWG. NO.	REV	A	TE-18004-01	
SIZE	DWG. NO.	REV											
A	TE-18004-01												
	APPLICATION			SCALE: 1:12	WEIGHT:	SHEET 1 OF 1							

2

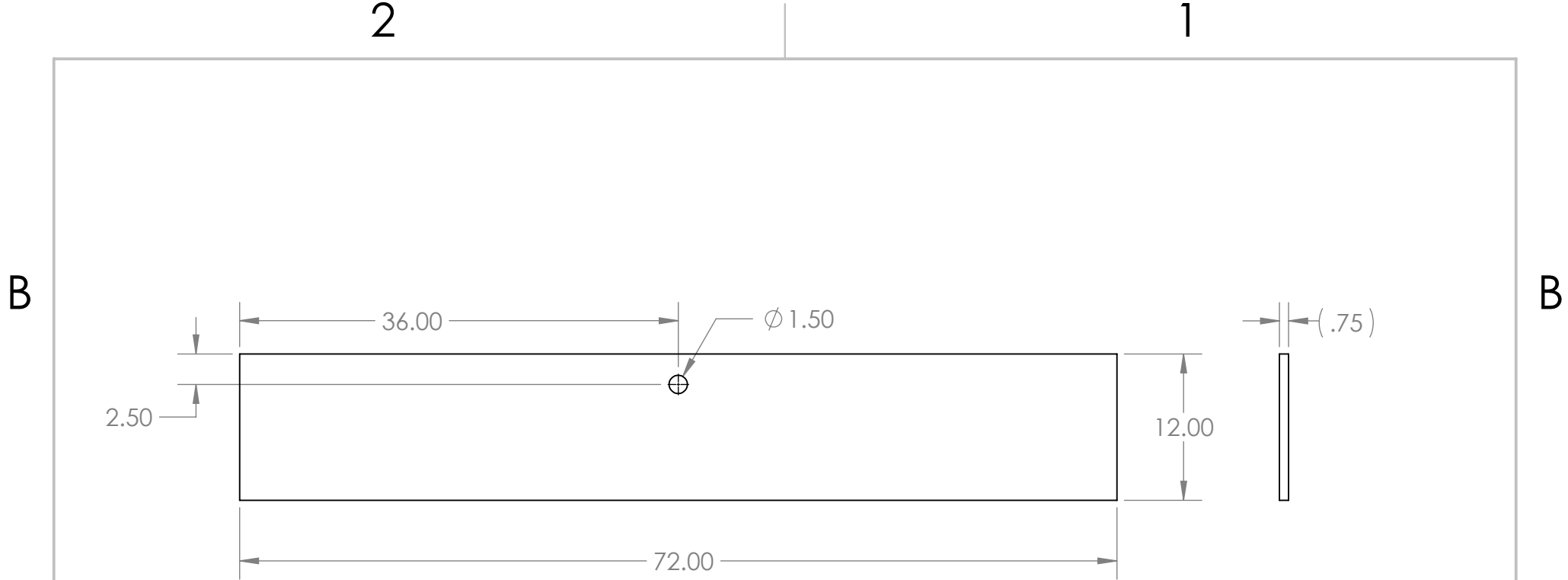

1



- Notes:
1. Material: 3/4" AC Plywood
 2. QTY. Needed: 2

PROPRIETARY AND CONFIDENTIAL
 THE INFORMATION CONTAINED IN THIS DRAWING IS THE SOLE PROPERTY OF **FIRST®**. Any REPRODUCTION IN PART OR AS A WHOLE WITHOUT THE WRITTEN PERMISSION OF **FIRST®** IS PROHIBITED.

		UNLESS OTHERWISE SPECIFIED:		NAME	DATE
		DIMENSIONS ARE IN INCHES	DRAWN		
		TOLERANCES:	CHECKED		
		FRACTIONAL ± 1/16	ENG APPR.		
		ANGULAR: MACH ± 1° BEND ± 1°	MFG APPR.		
		TWO PLACE DECIMAL ± .01	Q.A.		
		THREE PLACE DECIMAL ± .001	COMMENTS:		
		INTERPRET GEOMETRIC TOLERANCING PER:			
		MATERIAL			
		.75 Ply			
NEXT ASSY	USED ON	FINISH			
	APPLICATION	DO NOT SCALE DRAWING			

TITLE:

SIZE	DWG. NO.	REV
A	TE-18004-02	
SCALE: 1:12	WEIGHT:	SHEET 1 OF 1

2

1

B

B

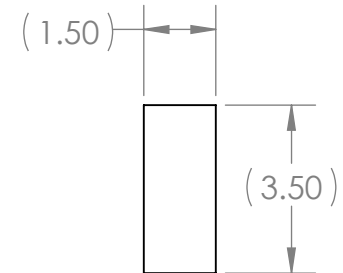
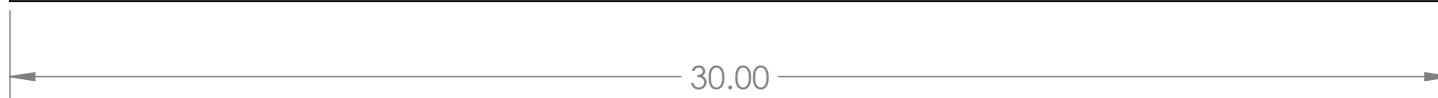
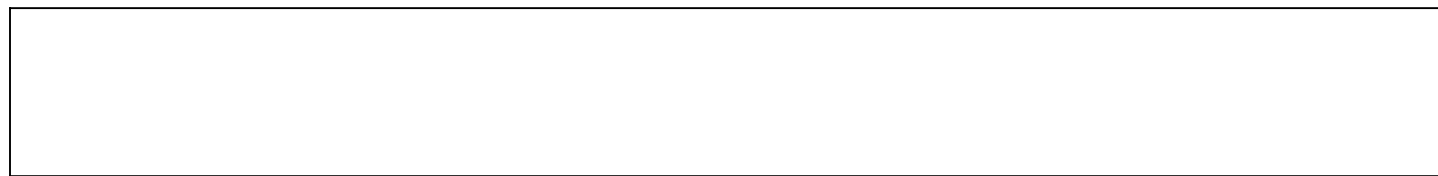

Notes:

- 1. Material: 2" x 4" Pine Lumber
- 2. QTY. Needed: 4

A

A

PROPRIETARY AND CONFIDENTIAL
 THE INFORMATION CONTAINED IN THIS DRAWING IS THE SOLE PROPERTY OF **FIRST®**. Any REPRODUCTION IN PART OR AS A WHOLE WITHOUT THE WRITTEN PERMISSION OF **FIRST®** IS PROHIBITED.

		UNLESS OTHERWISE SPECIFIED:		NAME	DATE
		DIMENSIONS ARE IN INCHES	DRAWN		
		TOLERANCES:	CHECKED		
		FRACTIONAL ± 1/16	ENG APPR.		
		ANGULAR: MACH ± 1° BEND ± 1°	MFG APPR.		
		TWO PLACE DECIMAL ± .01	Q.A.		
		THREE PLACE DECIMAL ± .001	COMMENTS:		
		INTERPRET GEOMETRIC TOLERANCING PER:			
		MATERIAL			
		2x4			
NEXT ASSY	USED ON	FINISH			
		DO NOT SCALE DRAWING			



TITLE:		
SIZE	DWG. NO.	REV
A	TE-18004-03	
SCALE: 1:4	WEIGHT:	SHEET 1 OF 1

2

1

2

1

B

B

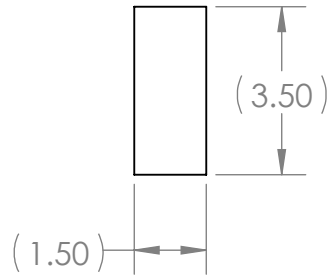
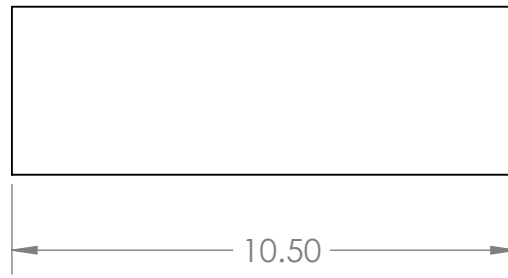

Notes:

- 1. Material: 2" x 4" Pine Lumber
- 2. QTY. Needed: 8

A

A

PROPRIETARY AND CONFIDENTIAL
 THE INFORMATION CONTAINED IN THIS DRAWING IS THE SOLE PROPERTY OF **FIRST®**. Any REPRODUCTION IN PART OR AS A WHOLE WITHOUT THE WRITTEN PERMISSION OF **FIRST®** IS PROHIBITED.

		UNLESS OTHERWISE SPECIFIED:		NAME	DATE
		DIMENSIONS ARE IN INCHES	DRAWN		
		TOLERANCES:	CHECKED		
		FRACTIONAL ± 1/16	ENG APPR.		
		ANGULAR: MACH ± 1° BEND ± 1°	MFG APPR.		
		TWO PLACE DECIMAL ± .01	Q.A.		
		THREE PLACE DECIMAL ± .001	COMMENTS:		
		INTERPRET GEOMETRIC TOLERANCING PER:			
		MATERIAL			
		2x4			
		FINISH			
NEXT ASSY	USED ON				
APPLICATION		DO NOT SCALE DRAWING			



TITLE:		
SIZE	DWG. NO.	REV
A	TE-18004-04	
SCALE: 1:4	WEIGHT:	SHEET 1 OF 1

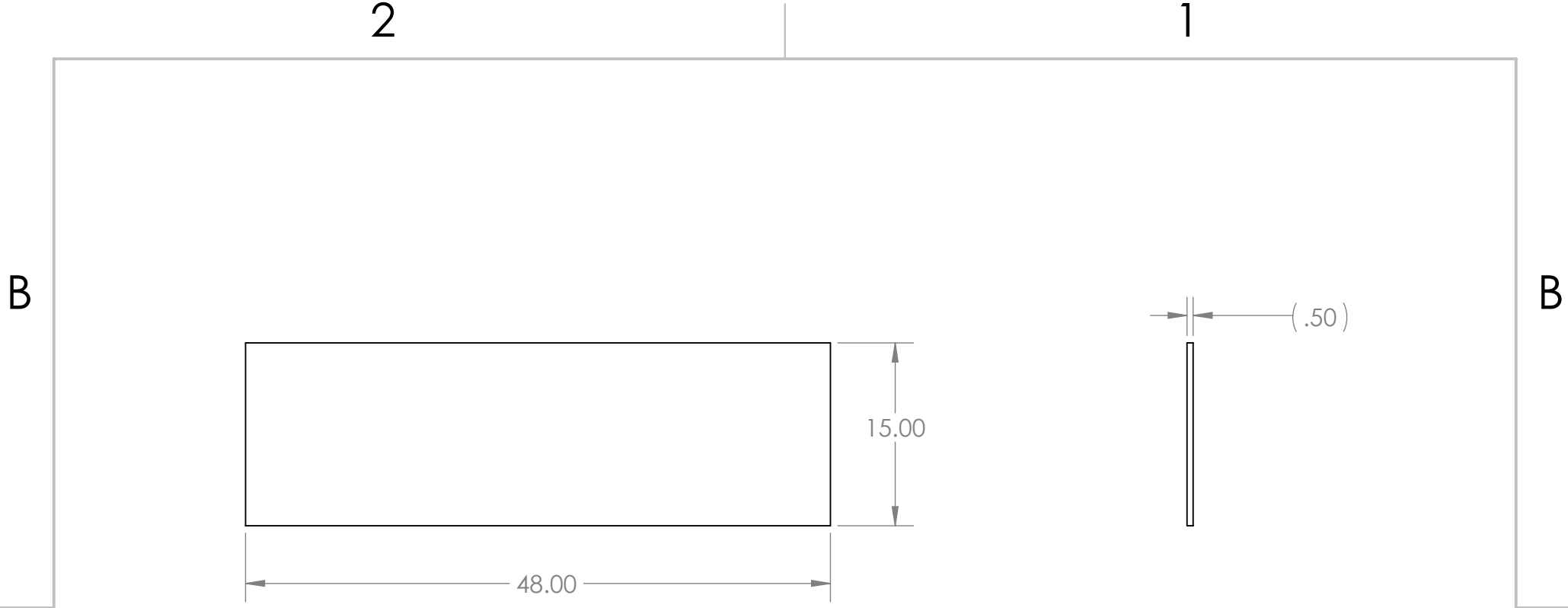

2

1



Notes:

1. Material: 1/2" AC Plywood
2. QTY. Needed: 2

<p>PROPRIETARY AND CONFIDENTIAL THE INFORMATION CONTAINED IN THIS DRAWING IS THE SOLE PROPERTY OF FIRST®. Any REPRODUCTION IN PART OR AS A WHOLE WITHOUT THE WRITTEN PERMISSION OF FIRST® IS PROHIBITED.</p>			UNLESS OTHERWISE SPECIFIED:		NAME	DATE	 		
			DIMENSIONS ARE IN INCHES TOLERANCES: FRACTIONAL $\pm 1/16$ ANGULAR: MACH $\pm 1^\circ$ BEND $\pm 1^\circ$ TWO PLACE DECIMAL $\pm .01$ THREE PLACE DECIMAL $\pm .001$	DRAWN				TITLE:	
			INTERPRET GEOMETRIC TOLERANCING PER:	CHECKED					
			MATERIAL 1/2" Ply	ENG APPR.					
			FINISH	MFG APPR.					
	NEXT ASSY	USED ON	DO NOT SCALE DRAWING	COMMENTS:			SIZE	DWG. NO.	REV
	APPLICATION						A	TE-18004-05	
							SCALE: 1:12	WEIGHT:	SHEET 1 OF 1

2

1

B

B

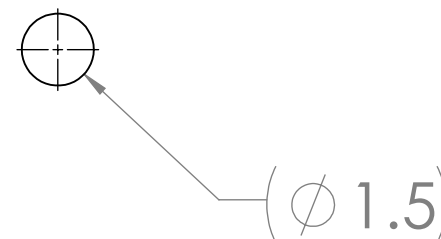



Notes:

- 1. Material: 1.5" Diameter Wood Dowel (Any Wood)
- 2. QTY. Needed: 1

A

A

PROPRIETARY AND CONFIDENTIAL THE INFORMATION CONTAINED IN THIS DRAWING IS THE SOLE PROPERTY OF FIRST® . Any REPRODUCTION IN PART OR AS A WHOLE WITHOUT THE WRITTEN PERMISSION OF FIRST® IS PROHIBITED.			UNLESS OTHERWISE SPECIFIED:		NAME	DATE	 
			DIMENSIONS ARE IN INCHES TOLERANCES: FRACTIONAL ± 1/16 ANGULAR: MACH ± 1° BEND ± 1° TWO PLACE DECIMAL ± .01 THREE PLACE DECIMAL ± .001	DRAWN			
			INTERPRET GEOMETRIC TOLERANCING PER:	CHECKED			
			MATERIAL	ENG APPR.			
			FINISH	MFG APPR.			
	NEXT ASSY	USED ON		Q.A.			
	APPLICATION		DO NOT SCALE DRAWING	COMMENTS:			

2

1

SCALE: 1:4 WEIGHT: SHEET 1 OF 1

2

1

B

B

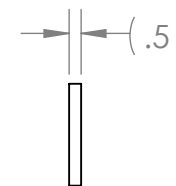
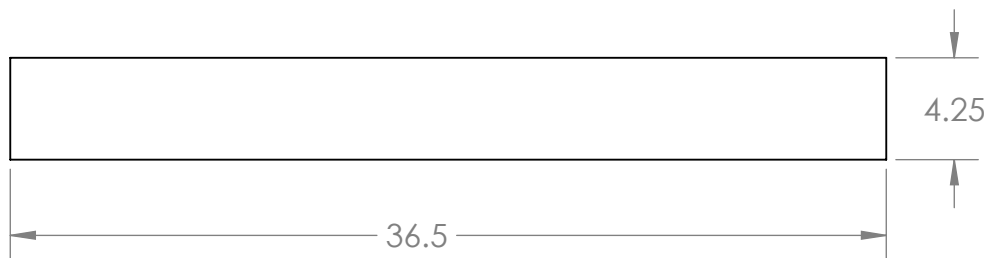

Notes:

- 1. Material: 1/2" AC Plywood
- 2. QTY. Needed: 4

A

A

PROPRIETARY AND CONFIDENTIAL
 THE INFORMATION CONTAINED IN THIS DRAWING IS THE SOLE PROPERTY OF **FIRST®**. Any REPRODUCTION IN PART OR AS A WHOLE WITHOUT THE WRITTEN PERMISSION OF **FIRST®** IS PROHIBITED.

		UNLESS OTHERWISE SPECIFIED:		NAME	DATE
		DIMENSIONS ARE IN INCHES	DRAWN		
		TOLERANCES:	CHECKED		
		FRACTIONAL ± 1/16	ENG APPR.		
		ANGULAR: MACH ± 1° BEND ± 1°	MFG APPR.		
		TWO PLACE DECIMAL ± .01	Q.A.		
		THREE PLACE DECIMAL ± .001	COMMENTS:		
		INTERPRET GEOMETRIC TOLERANCING PER:			
		MATERIAL			
		1/2" Ply			
		FINISH			
NEXT ASSY	USED ON				
	APPLICATION	DO NOT SCALE DRAWING			



TITLE:		
SIZE	DWG. NO.	REV
A	TE-18004-07	
SCALE: 1:8	WEIGHT:	SHEET 1 OF 1

2

1

2

1

B

B

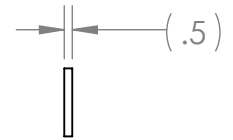
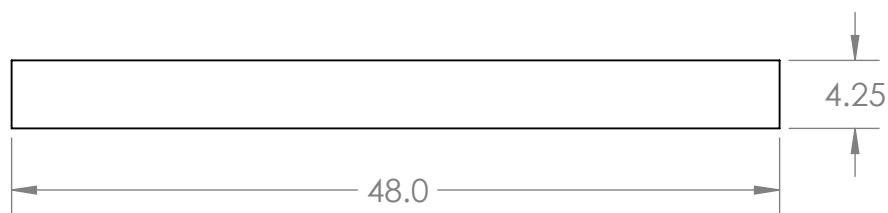

Notes:

- 1. Material: 1/2" AC Plywood
- 2. QTY. Needed: 2

A

A

PROPRIETARY AND CONFIDENTIAL
 THE INFORMATION CONTAINED IN THIS DRAWING IS THE SOLE PROPERTY OF **FIRST®**. Any REPRODUCTION IN PART OR AS A WHOLE WITHOUT THE WRITTEN PERMISSION OF **FIRST®** IS PROHIBITED.

		UNLESS OTHERWISE SPECIFIED:		NAME	DATE
		DIMENSIONS ARE IN INCHES	DRAWN		
		TOLERANCES:	CHECKED		
		FRACTIONAL ± 1/16	ENG APPR.		
		ANGULAR: MACH ± 1° BEND ± 1°	MFG APPR.		
		TWO PLACE DECIMAL ± .01	Q.A.		
		THREE PLACE DECIMAL ± .001	COMMENTS:		
		INTERPRET GEOMETRIC TOLERANCING PER:			
		MATERIAL			
		1/2 Ply			
NEXT ASSY	USED ON	FINISH			
		APPLICATION			
		DO NOT SCALE DRAWING			



TITLE:		
SIZE	DWG. NO.	REV
A	TE-18004-08	
SCALE: 1:12	WEIGHT:	SHEET 1 OF 1

2

1

4

3

2

1

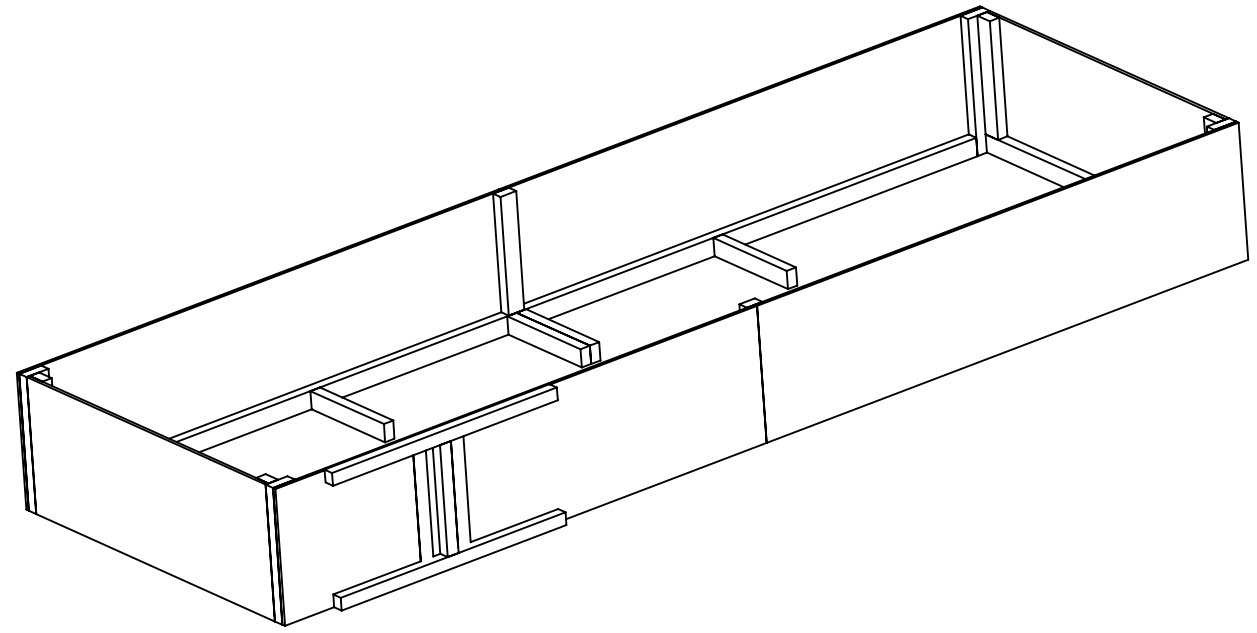

ITEM NO.	PART NUMBER	DESCRIPTION	QTY.
1	TE-18005-1		4
2	TE-18005-2		2
3	TE-18005-3		4
4	TE-18005-4		8
5	TE-18005-5		4
6	TE-18005-6		2
7	TE-18005-7		2
8	TE-18005-8		1
9	TE-18005-9		2
10	TE-18005-10		6

		UNLESS OTHERWISE SPECIFIED:		NAME	DATE
		DIMENSIONS ARE IN INCHES TOLERANCES: FRACTIONAL ±1/16 ANGULAR: MACH ±1° BEND ±1° TWO PLACE DECIMAL ±.01 THREE PLACE DECIMAL ±.001		DRAWN	
		INTERPRET GEOMETRIC TOLERANCING PER:		CHECKED	
		MATERIAL		ENG APPR.	
		FINISH		MFG APPR.	
NEXT ASSY	USED ON			Q.A.	
APPLICATION		DO NOT SCALE DRAWING		COMMENTS:	

PROPRIETARY AND CONFIDENTIAL
THE INFORMATION CONTAINED IN THIS DRAWING IS THE SOLE PROPERTY OF <INSERT COMPANY NAME HERE>. ANY REPRODUCTION IN PART OR AS A WHOLE WITHOUT THE WRITTEN PERMISSION OF <INSERT COMPANY NAME HERE> IS PROHIBITED.

TITLE:
Fence

SIZE DWG. NO. REV
B TE-18005

SCALE: 1:24 WEIGHT: SHEET 1 OF 3

4

3

2

1

B

B

A

A

4

3

2

1

B

B

A

A

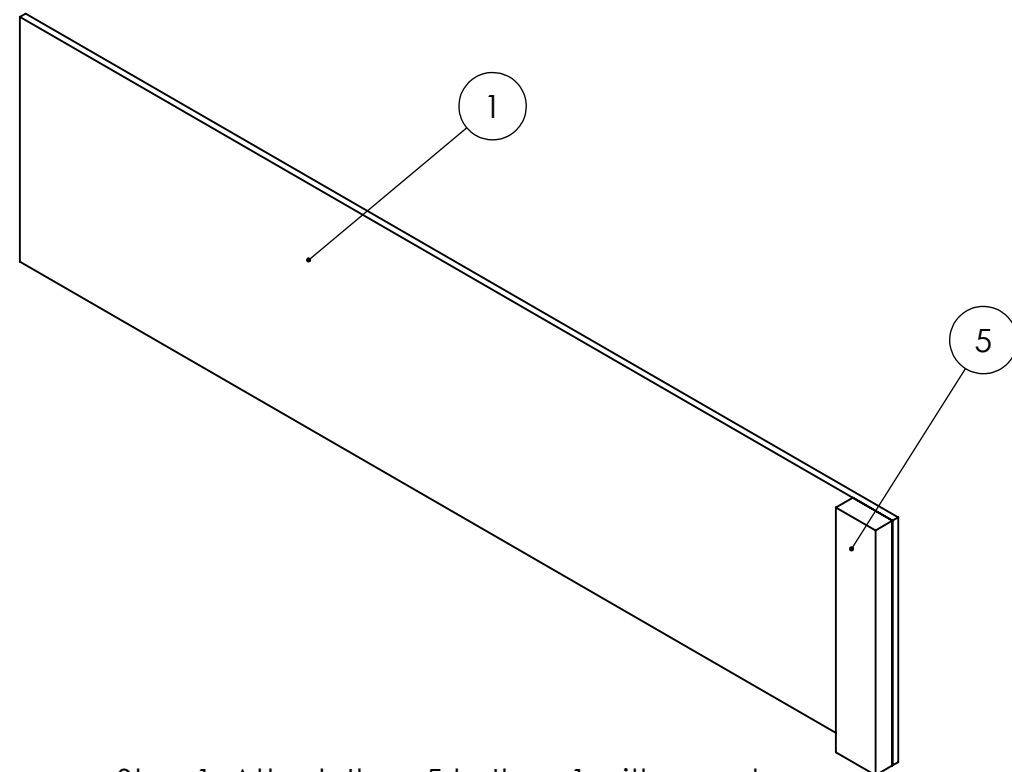

Step 1: Attach Item 5 to Item 1 with wood screws. Build 4.

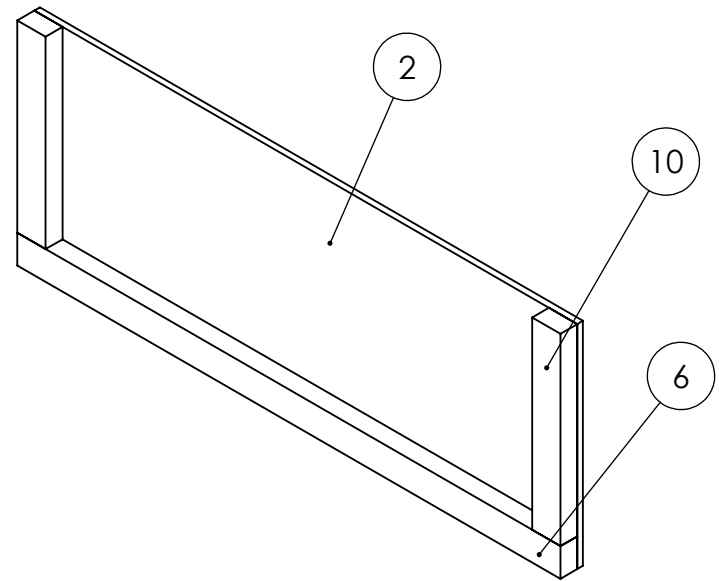

Step 2: Attach Item 10 (qty. 2) and Item 6 to Item 2 with wood screws. Build 2.

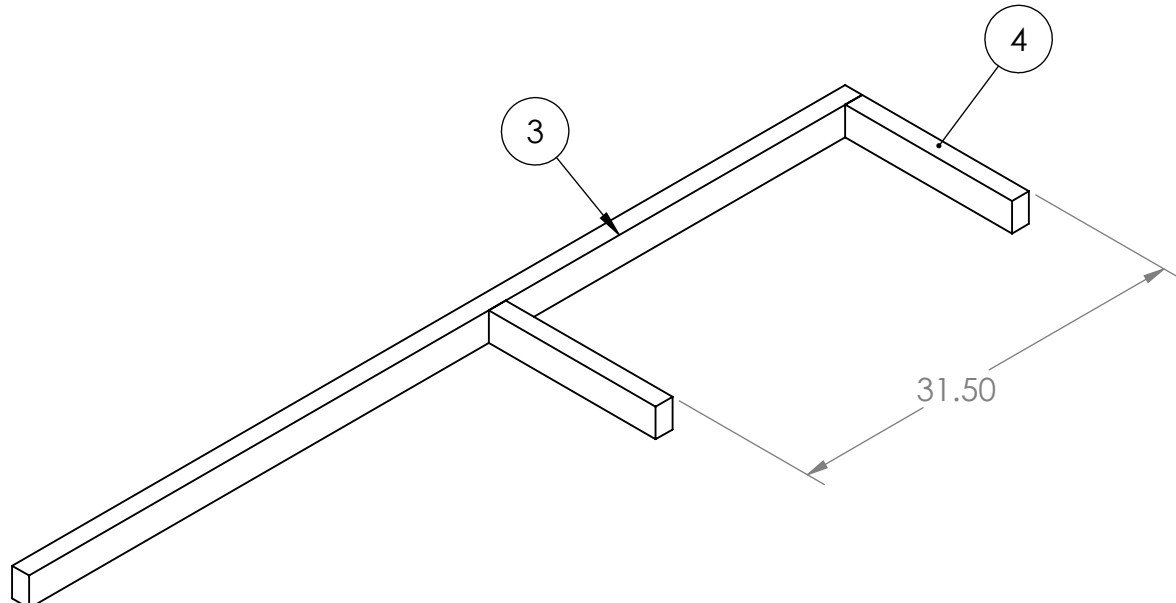

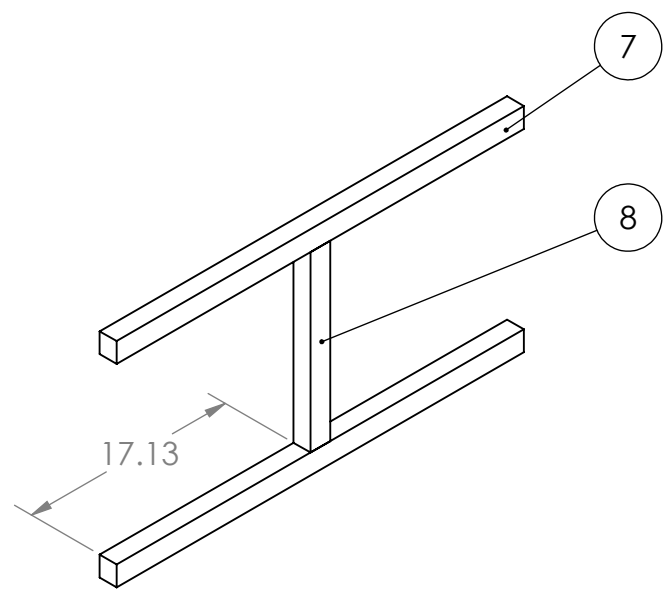

Step 3: Attach Item 4 (qty. 2) to Item 3 with wood screws. Build 4.



Step 4 (optional): Attach Item 7 (qty. 2) to Item 8 with wood screws. Only build if team is using vision targets.

PROPRIETARY AND CONFIDENTIAL
 THE INFORMATION CONTAINED IN THIS DRAWING IS THE SOLE PROPERTY OF <INSERT COMPANY NAME HERE>. ANY REPRODUCTION IN PART OR AS A WHOLE WITHOUT THE WRITTEN PERMISSION OF <INSERT COMPANY NAME HERE> IS PROHIBITED.

		UNLESS OTHERWISE SPECIFIED:		NAME	DATE	 
		DIMENSIONS ARE IN INCHES TOLERANCES: FRACTIONAL $\pm 1/16$ ANGULAR: MACH $\pm 1^\circ$ BEND $\pm 1^\circ$ TWO PLACE DECIMAL $\pm .01$ THREE PLACE DECIMAL $\pm .001$		DRAWN		
		INTERPRET GEOMETRIC TOLERANCING PER:		CHECKED		SIZE DWG. NO. REV
		MATERIAL		ENG APPR.		B TE-18005
NEXT ASSY		USED ON		MFG APPR.		SCALE: 1:24 WEIGHT: SHEET 2 OF 3
APPLICATION		DO NOT SCALE DRAWING		Q.A.		
				COMMENTS:		

4

3

2

1

B

B

A

A

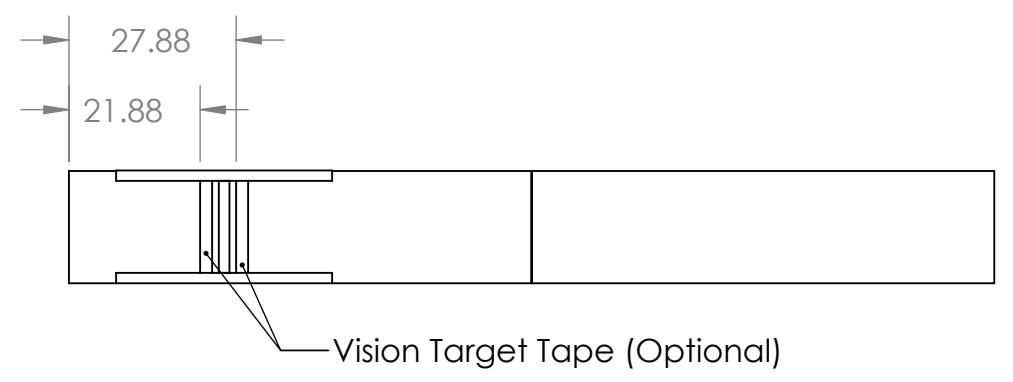
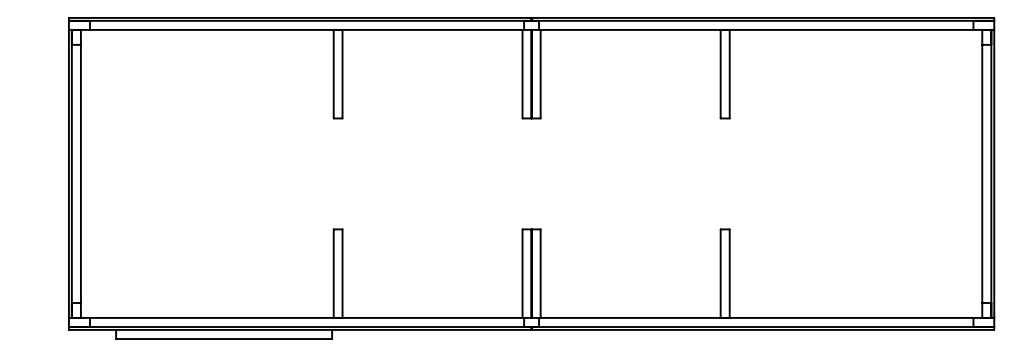
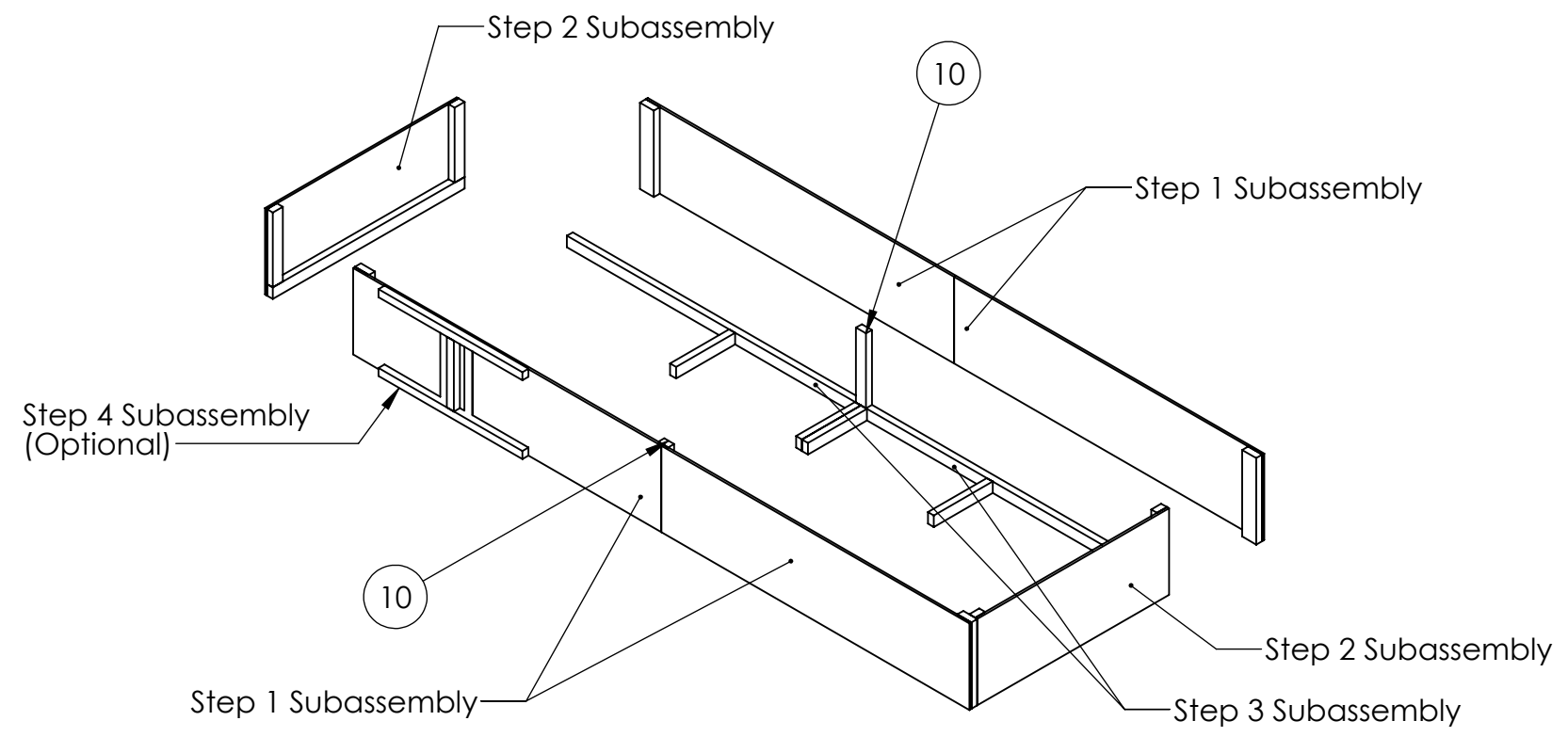

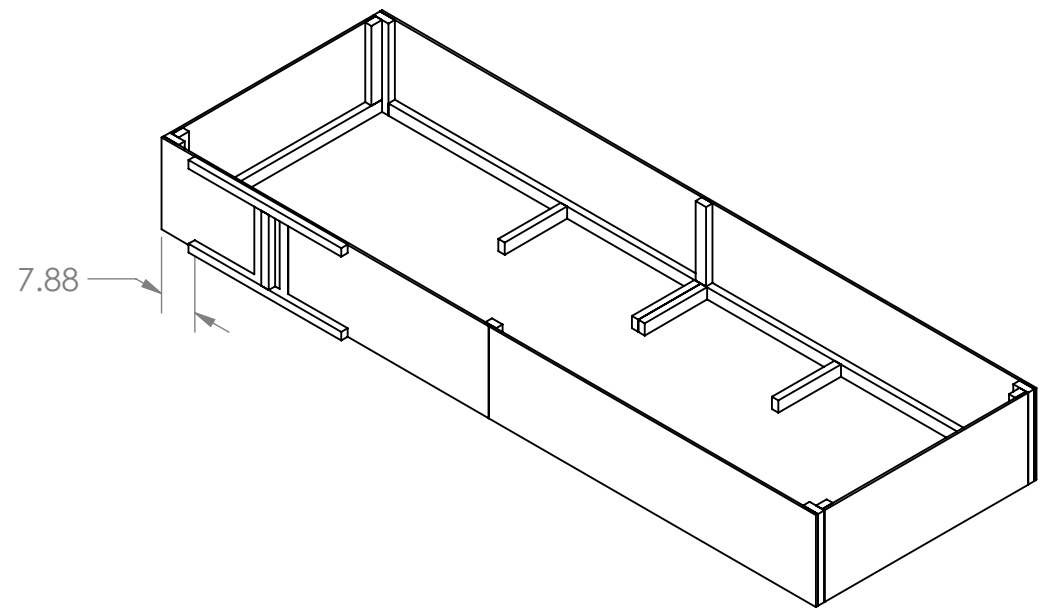

Step 6 (Optional): Attach vision tape as shown.



Step 5: Attach all subassemblies as shown using wood screw. Pre-drill to avoid splitting.

PROPRIETARY AND CONFIDENTIAL
 THE INFORMATION CONTAINED IN THIS DRAWING IS THE SOLE PROPERTY OF <INSERT COMPANY NAME HERE>. ANY REPRODUCTION IN PART OR AS A WHOLE WITHOUT THE WRITTEN PERMISSION OF <INSERT COMPANY NAME HERE> IS PROHIBITED.

		UNLESS OTHERWISE SPECIFIED:		NAME	DATE
		DIMENSIONS ARE IN INCHES TOLERANCES: FRACTIONAL: ±1/16 ANGULAR: MACH ±1° BEND ±1° TWO PLACE DECIMAL ±.01 THREE PLACE DECIMAL ±.001		DRAWN	
		INTERPRET GEOMETRIC TOLERANCING PER:		CHECKED	
		MATERIAL		ENG APPR.	
		FINISH		MFG APPR.	
NEXT ASSY	USED ON			Q.A.	
APPLICATION		DO NOT SCALE DRAWING		COMMENTS:	
				 	
				TITLE: Fence	
SIZE	DWG. NO.	REV			
B	TE-18005				
SCALE: 1:32			WEIGHT:	SHEET 3 OF 3	

4

3

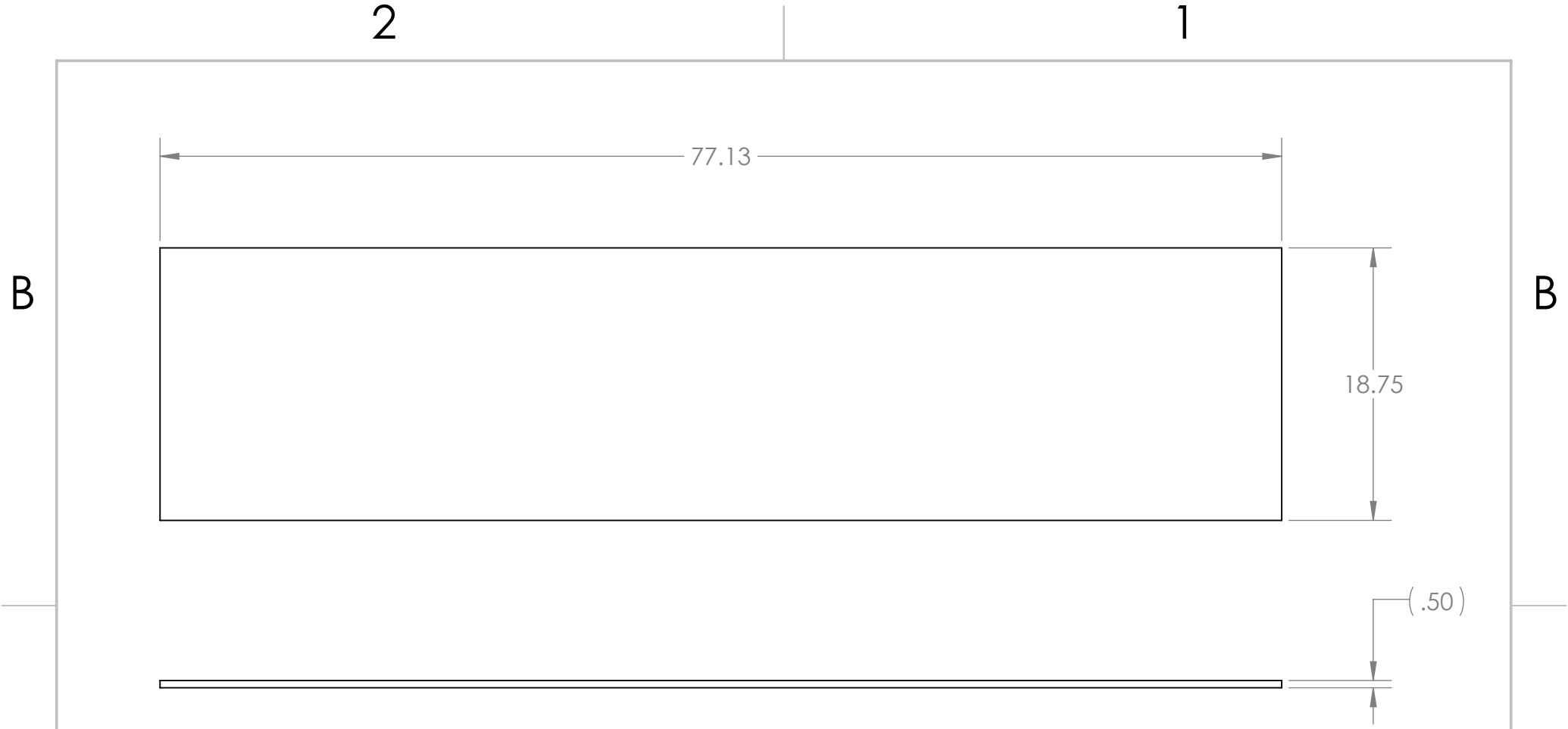

2

1



Notes:

1. Material: 1/2" AC Plywood
2. QTY. Needed: 4

<p>PROPRIETARY AND CONFIDENTIAL THE INFORMATION CONTAINED IN THIS DRAWING IS THE SOLE PROPERTY OF FIRST®. ANY REPRODUCTION IN PART OR AS A WHOLE WITHOUT THE WRITTEN PERMISSION OF FIRST® IS PROHIBITED.</p>			UNLESS OTHERWISE SPECIFIED:		NAME	DATE	 		
			DIMENSIONS ARE IN INCHES TOLERANCES: FRACTIONAL ± 1/16 ANGULAR: MACH ± 1° BEND ± 1° TWO PLACE DECIMAL ± .01 THREE PLACE DECIMAL ± .001	DRAWN				TITLE:	
			INTERPRET GEOMETRIC TOLERANCING PER:	CHECKED					
			MATERIAL	ENG APPR.					
			FINISH	MFG APPR.					
	NEXT ASSY	USED ON		Q.A.			SIZE	DWG. NO.	REV
	APPLICATION		DO NOT SCALE DRAWING	COMMENTS:			A	TE-18005-1	
							SCALE: 1:10	WEIGHT:	SHEET 1 OF 1

A

A

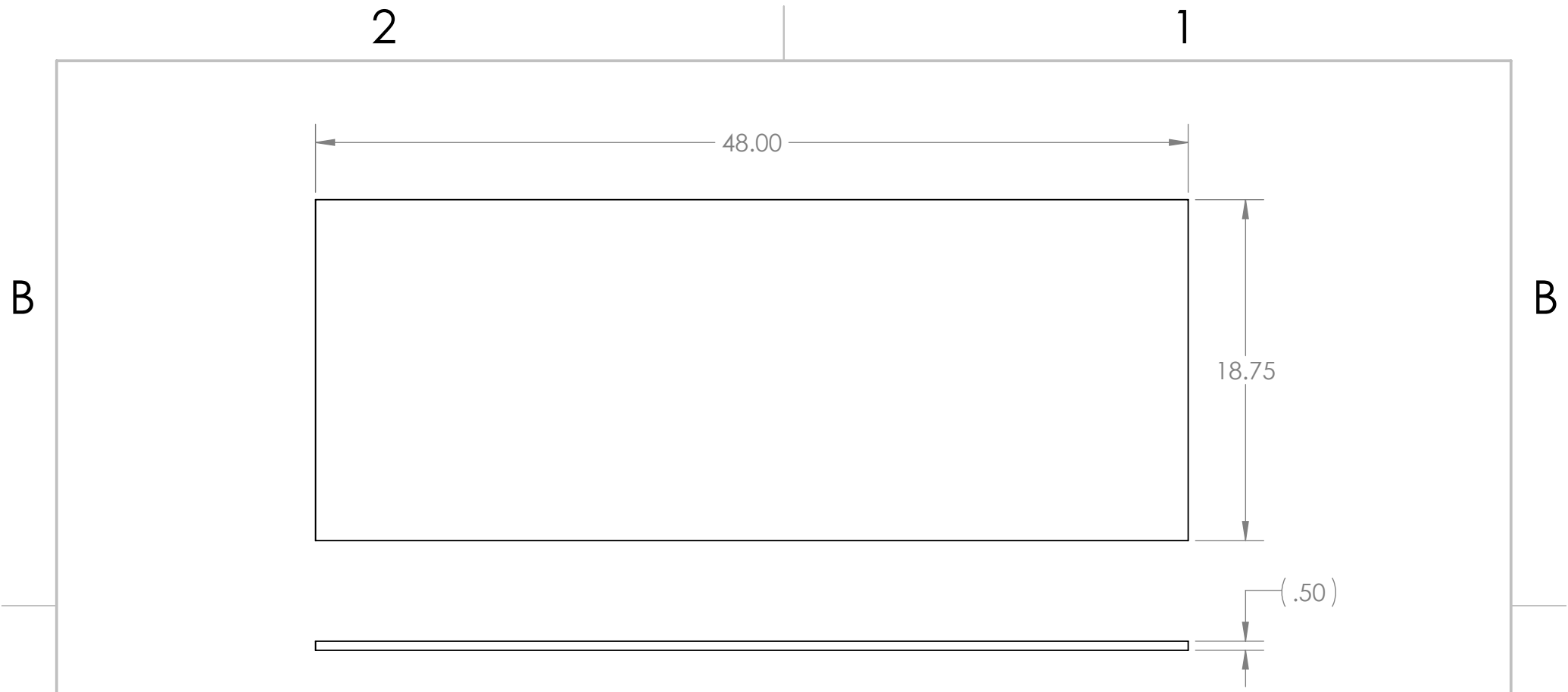

2

1



Notes:

1. Material: 1/2" AC Plywood
2. QTY. Needed: 2

<p>PROPRIETARY AND CONFIDENTIAL THE INFORMATION CONTAINED IN THIS DRAWING IS THE SOLE PROPERTY OF FIRST®. ANY REPRODUCTION IN PART OR AS A WHOLE WITHOUT THE WRITTEN PERMISSION OF FIRST® IS PROHIBITED.</p>			UNLESS OTHERWISE SPECIFIED:		NAME	DATE	 	<p>TITLE:</p>	
			DIMENSIONS ARE IN INCHES	DRAWN					
			TOLERANCES:	CHECKED					
			FRACTIONAL ± 1/16	ENG APPR.					
			ANGULAR: MACH ± 1° BEND ± 1°	MFG APPR.					
		TWO PLACE DECIMAL ± .01	Q.A.						
		THREE PLACE DECIMAL ± .001	COMMENTS:						
		INTERPRET GEOMETRIC TOLERANCING PER:	MATERIAL				SIZE	DWG. NO.	REV
			FINISH				A	TE-18005-2	
NEXT ASSY	USED ON						SCALE: 1:8	WEIGHT:	SHEET 1 OF 1
APPLICATION			DO NOT SCALE DRAWING						

2

1

2

1

B

B

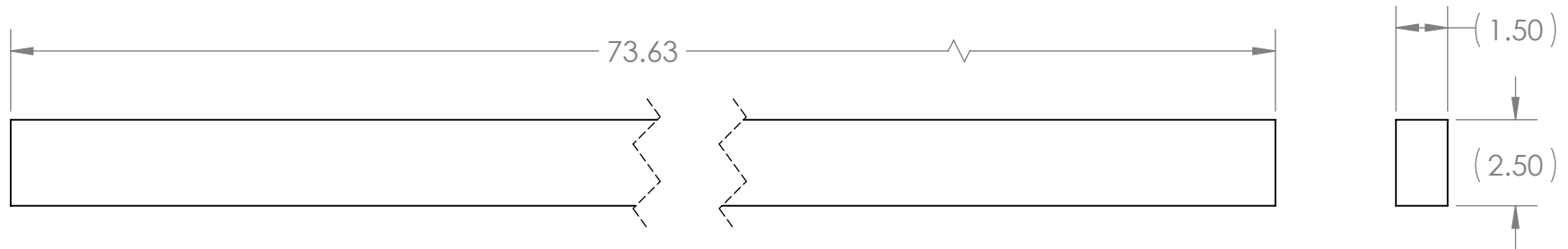

Notes:

1. Material: 2" x 3" Pine Lumber
2. QTY. Needed: 4

A

A

PROPRIETARY AND CONFIDENTIAL
 THE INFORMATION CONTAINED IN THIS DRAWING IS THE SOLE PROPERTY OF **FIRST®**. ANY REPRODUCTION IN PART OR AS A WHOLE WITHOUT THE WRITTEN PERMISSION OF **FIRST®** IS PROHIBITED.

		UNLESS OTHERWISE SPECIFIED:		NAME	DATE
		DIMENSIONS ARE IN INCHES	DRAWN		
		TOLERANCES:	CHECKED		
		FRACTIONAL ± 1/16	ENG APPR.		
		ANGULAR: MACH ± 1° BEND ± 1°	MFG APPR.		
		TWO PLACE DECIMAL ± .01	Q.A.		
		THREE PLACE DECIMAL ± .001	COMMENTS:		
		INTERPRET GEOMETRIC TOLERANCING PER:			
		MATERIAL			
		FINISH			
NEXT ASSY	USED ON				
APPLICATION		DO NOT SCALE DRAWING			



TITLE:		
SIZE	DWG. NO.	REV
A	TE-18005-3	
SCALE: 1:5	WEIGHT:	SHEET 1 OF 1

2

1

2

1

B

B

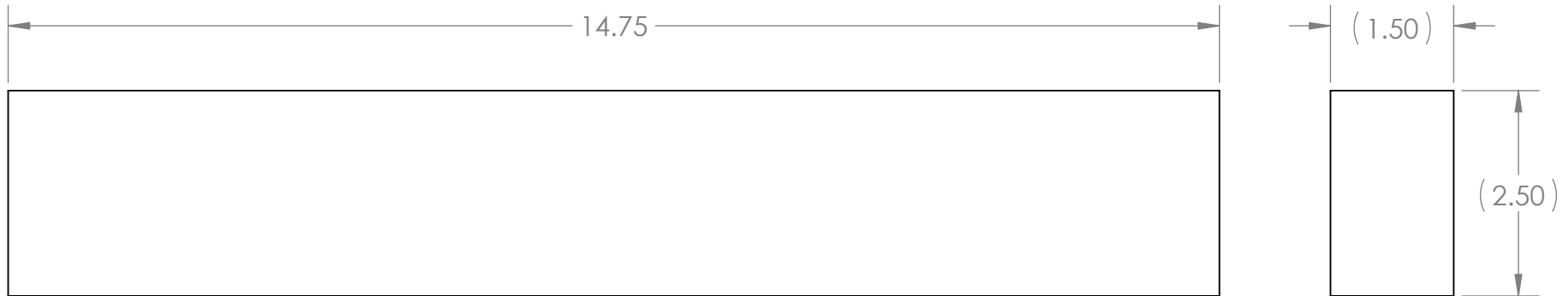



Notes:

- 1. Material: 2" x 3" Pine Lumber
- 2. QTY. Needed: 8

A

A

PROPRIETARY AND CONFIDENTIAL
 THE INFORMATION CONTAINED IN THIS DRAWING IS THE SOLE PROPERTY OF **FIRST®**. ANY REPRODUCTION IN PART OR AS A WHOLE WITHOUT THE WRITTEN PERMISSION OF **FIRST®** IS PROHIBITED.

		UNLESS OTHERWISE SPECIFIED:		NAME	DATE	 
		DIMENSIONS ARE IN INCHES TOLERANCES: FRACTIONAL ± 1/16 ANGULAR: MACH ± 1° BEND ± 1° TWO PLACE DECIMAL ± .01 THREE PLACE DECIMAL ± .001	DRAWN			
		INTERPRET GEOMETRIC TOLERANCING PER:	CHECKED			
		MATERIAL	ENG APPR.			
		FINISH	MFG APPR.			
NEXT ASSY	USED ON		Q.A.			SIZE DWG. NO. REV A TE-18005-4
APPLICATION		DO NOT SCALE DRAWING	COMMENTS:			
			SCALE: 1:2	WEIGHT:	SHEET 1 OF 1	

2

1

2

1

B

B

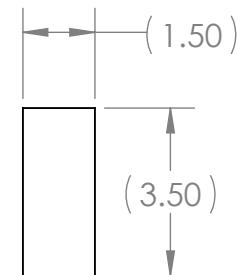
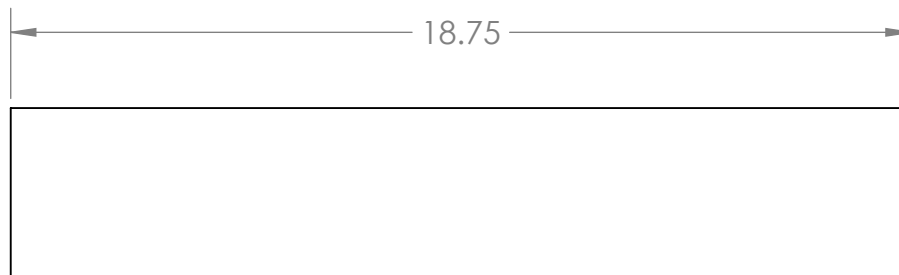

Notes:

1. Material: 2" x 4" Pine Lumber
2. QTY. Needed: 4

A

A

PROPRIETARY AND CONFIDENTIAL
 THE INFORMATION CONTAINED IN THIS DRAWING IS THE SOLE PROPERTY OF **FIRST®**. ANY REPRODUCTION IN PART OR AS A WHOLE WITHOUT THE WRITTEN PERMISSION OF **FIRST®** IS PROHIBITED.

		UNLESS OTHERWISE SPECIFIED:		NAME	DATE
		DIMENSIONS ARE IN INCHES	DRAWN		
		TOLERANCES:	CHECKED		
		FRACTIONAL ± 1/16	ENG APPR.		
		ANGULAR: MACH ± 1° BEND ± 1°	MFG APPR.		
		TWO PLACE DECIMAL ± .01	Q.A.		
		THREE PLACE DECIMAL ± .001	COMMENTS:		
		INTERPRET GEOMETRIC TOLERANCING PER:			
		MATERIAL			
	NEXT ASSY	FINISH			
	USED ON				
	APPLICATION	DO NOT SCALE DRAWING			



TITLE:		
SIZE	DWG. NO.	REV
A	TE-18005-5	
SCALE: 1:4	WEIGHT:	SHEET 1 OF 1

2

1

2

1

B

B

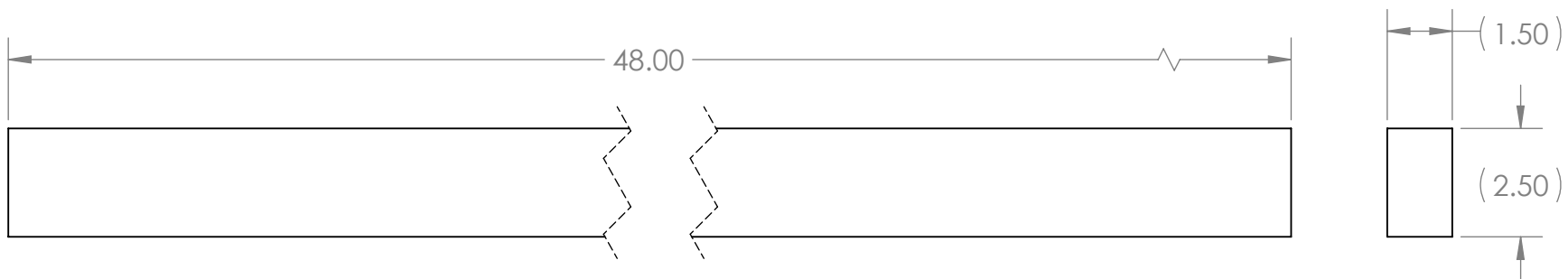

Notes:

1. Material: 2" x 3" Pine Lumber
2. QTY. Needed: 2

A

A

PROPRIETARY AND CONFIDENTIAL
 THE INFORMATION CONTAINED IN THIS DRAWING IS THE SOLE PROPERTY OF **FIRST®**. ANY REPRODUCTION IN PART OR AS A WHOLE WITHOUT THE WRITTEN PERMISSION OF **FIRST®** IS PROHIBITED.

		UNLESS OTHERWISE SPECIFIED:		NAME	DATE
		DIMENSIONS ARE IN INCHES	DRAWN		
		TOLERANCES:	CHECKED		
		FRACTIONAL ± 1/16	ENG APPR.		
		ANGULAR: MACH ± 1° BEND ± 1°	MFG APPR.		
		TWO PLACE DECIMAL ± .01	Q.A.		
		THREE PLACE DECIMAL ± .001	COMMENTS:		
		INTERPRET GEOMETRIC TOLERANCING PER:			
		MATERIAL			
		FINISH			
NEXT ASSY	USED ON				
APPLICATION		DO NOT SCALE DRAWING			



TITLE:		
SIZE	DWG. NO.	REV
A	TE-18005-6	
SCALE: 1:4	WEIGHT:	SHEET 1 OF 1

2

1

2

1

B

B

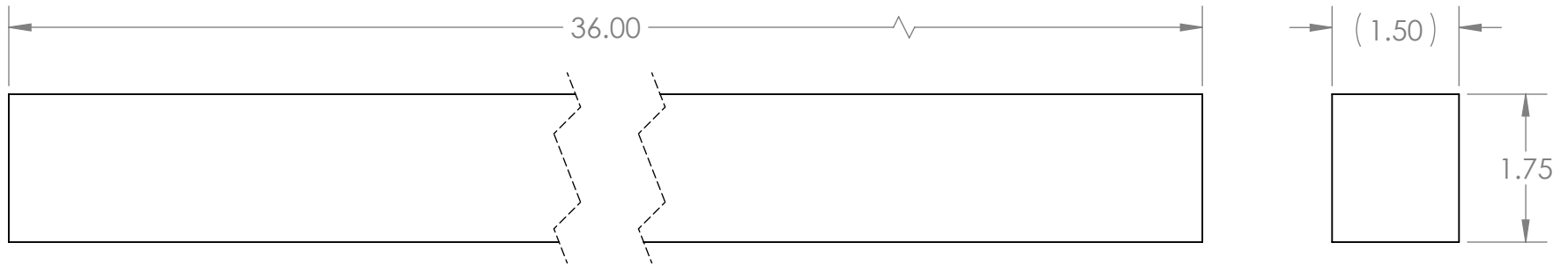



Notes:

1. Material: 2" x 4" Pine Lumber
2. QTY. Needed: 2
3. This part is only necessary for use with an optional vision target component of the assembly. If retroreflective tape is not going to be applied, this part is not necessary.
4. The 1.75" material height may be undersized to allow for cutting blade thickness.

A

A

<p>PROPRIETARY AND CONFIDENTIAL THE INFORMATION CONTAINED IN THIS DRAWING IS THE SOLE PROPERTY OF FIRST®. ANY REPRODUCTION IN PART OR AS A WHOLE WITHOUT THE WRITTEN PERMISSION OF FIRST® IS PROHIBITED.</p>			UNLESS OTHERWISE SPECIFIED:		NAME	DATE	 		
			DIMENSIONS ARE IN INCHES TOLERANCES: FRACTIONAL ± 1/16 ANGULAR: MACH ± 1° BEND ± 1° TWO PLACE DECIMAL ± .01 THREE PLACE DECIMAL ± .001	DRAWN				TITLE:	
			INTERPRET GEOMETRIC TOLERANCING PER:	CHECKED					
			MATERIAL	ENG APPR.					
			FINISH	MFG APPR.					
	NEXT ASSY	USED ON		Q.A.			SIZE	DWG. NO.	REV
	APPLICATION		DO NOT SCALE DRAWING	COMMENTS:			A	TE-18005-7	
							SCALE: 1:2	WEIGHT:	SHEET 1 OF 1

2

1

2

1

B

B

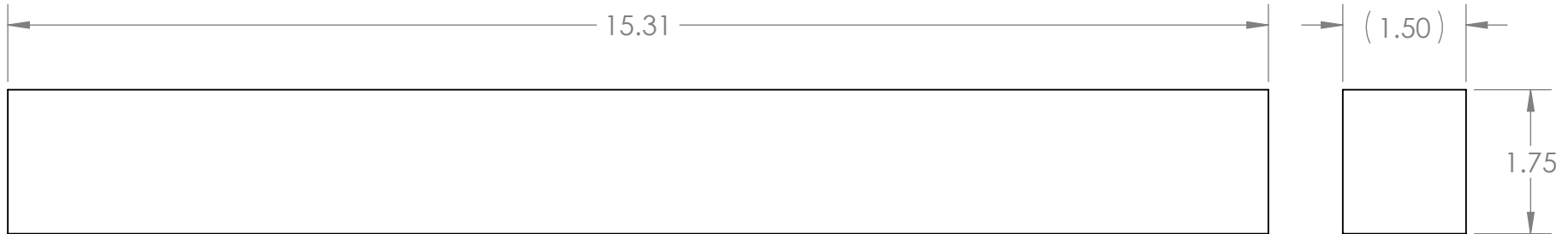

Notes:

1. Material: 2" x 4" Pine Lumber
2. QTY. Needed: 1
3. This part is only necessary for use with an optional vision target component of the assembly. If retroreflective tape is not going to be applied, this part is not necessary.
4. The 1.75" material height may be undersized to allow for cutting blade thickness.

A

A

PROPRIETARY AND CONFIDENTIAL
 THE INFORMATION CONTAINED IN THIS DRAWING IS THE SOLE PROPERTY OF **FIRST®**. ANY REPRODUCTION IN PART OR AS A WHOLE WITHOUT THE WRITTEN PERMISSION OF **FIRST®** IS PROHIBITED.

		UNLESS OTHERWISE SPECIFIED:		NAME	DATE
		DIMENSIONS ARE IN INCHES	DRAWN		
		TOLERANCES:	CHECKED		
		FRACTIONAL ± 1/16	ENG APPR.		
		ANGULAR: MACH ± 1° BEND ± 1°	MFG APPR.		
		TWO PLACE DECIMAL ± .01	Q.A.		
		THREE PLACE DECIMAL ± .001	COMMENTS:		
		INTERPRET GEOMETRIC TOLERANCING PER:			
		MATERIAL			
	NEXT ASSY	USED ON			
		FINISH			
		APPLICATION			
		DO NOT SCALE DRAWING			



TITLE:		
SIZE	DWG. NO.	REV
A	TE-18005-8	
SCALE: 1:2	WEIGHT:	SHEET 1 OF 1

2

1

2

1

B

B

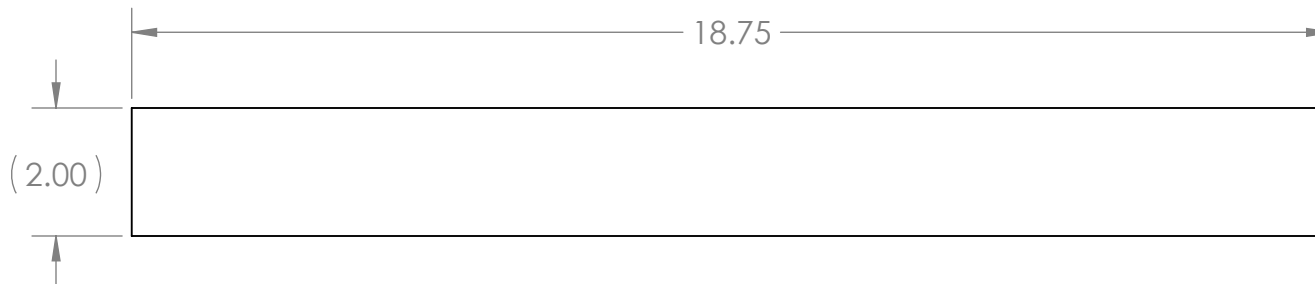

Notes:

1. Material: 2" Retroreflective tape
2. QTY. Needed: 2
3. This part is only necessary for use with an optional vision target component of the assembly.

A

A

PROPRIETARY AND CONFIDENTIAL
 THE INFORMATION CONTAINED IN THIS DRAWING IS THE SOLE PROPERTY OF **FIRST®**. ANY REPRODUCTION IN PART OR AS A WHOLE WITHOUT THE WRITTEN PERMISSION OF **FIRST®** IS PROHIBITED.

		UNLESS OTHERWISE SPECIFIED:		NAME	DATE
		DIMENSIONS ARE IN INCHES	DRAWN		
		TOLERANCES:	CHECKED		
		FRACTIONAL ± 1/16	ENG APPR.		
		ANGULAR: MACH ± 1° BEND ± 1°	MFG APPR.		
		TWO PLACE DECIMAL ± .01	Q.A.		
		THREE PLACE DECIMAL ± .001	COMMENTS:		
		INTERPRET GEOMETRIC TOLERANCING PER:			
		MATERIAL			
NEXT ASSY	USED ON	FINISH			
APPLICATION		DO NOT SCALE DRAWING			



TITLE:		
SIZE	DWG. NO.	REV
A	TE-18005-9	
SCALE: 1:3	WEIGHT:	SHEET 1 OF 1

2

1

2

1

B

B

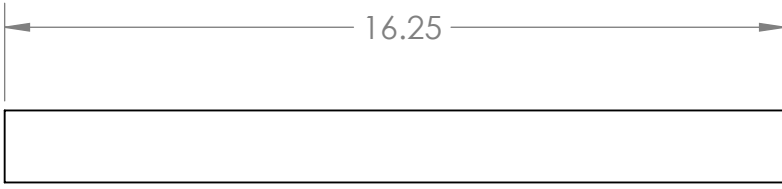
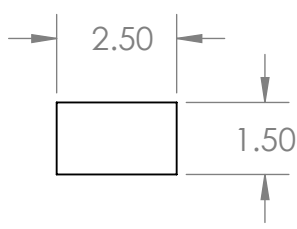

- Notes:
 1. Material: 2" x 3" Pine Lumber (1.5" x 2.5" actual)
 2. Qty. needed: 6

A

A

PROPRIETARY AND CONFIDENTIAL

THE INFORMATION CONTAINED IN THIS DRAWING IS THE SOLE PROPERTY OF **FIRST®**. Any REPRODUCTION IN PART OR AS A WHOLE WITHOUT THE WRITTEN PERMISSION OF **FIRST®** IS PROHIBITED.

		UNLESS OTHERWISE SPECIFIED:		NAME	DATE
		DIMENSIONS ARE IN INCHES	DRAWN		
		TOLERANCES:	CHECKED		
		FRACTIONAL ± 1/16	ENG APPR.		
		ANGULAR: MACH ± 1° BEND ± 1°	MFG APPR.		
		TWO PLACE DECIMAL ± .01	Q.A.		
		THREE PLACE DECIMAL ± .001	COMMENTS:		
		INTERPRET GEOMETRIC TOLERANCING PER:			
		MATERIAL			
		FINISH			
NEXT ASSY	USED ON				
APPLICATION		DO NOT SCALE DRAWING			



TITLE:		
SIZE	DWG. NO.	REV
A	TE-18005-10	
SCALE: 1:4	WEIGHT:	SHEET 1 OF 1

2

1

B

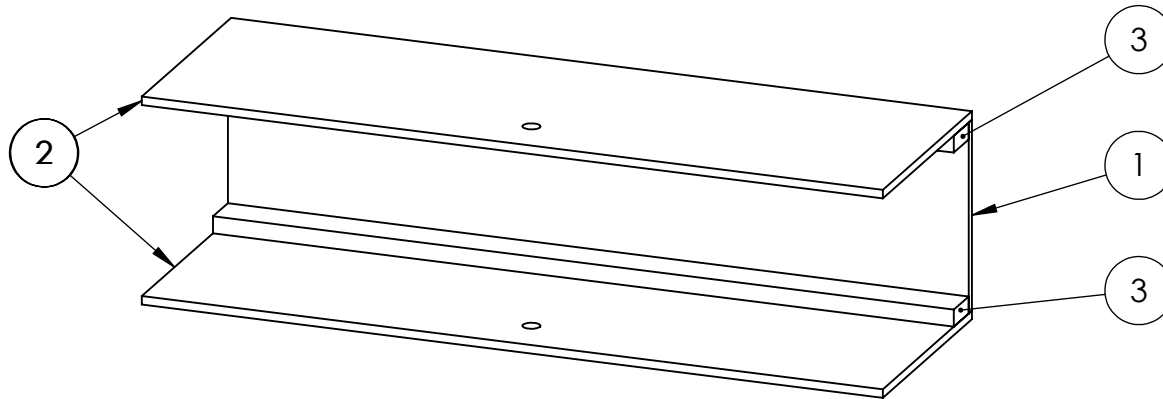



Align parts as shown and secure with wood screws or staples.

ITEM NO.	PART NUMBER	DESCRIPTION	QTY.
1	TE-18006-01		1
2	TE-18006-02		2
3	TE-18006-03		2

B

A

A

<p>PROPRIETARY AND CONFIDENTIAL THE INFORMATION CONTAINED IN THIS DRAWING IS THE SOLE PROPERTY OF FIRST®. Any REPRODUCTION IN PART OR AS A WHOLE WITHOUT THE WRITTEN PERMISSION OF FIRST® IS PROHIBITED.</p>			UNLESS OTHERWISE SPECIFIED:		NAME	DATE	 		
			DIMENSIONS ARE IN INCHES TOLERANCES: FRACTIONAL $\pm 1/16$ ANGULAR: MACH $\pm 1^\circ$ BEND $\pm 1^\circ$ TWO PLACE DECIMAL $\pm .01$ THREE PLACE DECIMAL $\pm .001$	DRAWN				<p>TITLE: Switch Frame</p>	
			INTERPRET GEOMETRIC TOLERANCING PER:	CHECKED					
			MATERIAL	ENG APPR.					
			FINISH	MFG APPR.					
	NEXT ASSY	USED ON		Q.A.			SIZE	DWG. NO.	REV
		APPLICATION	DO NOT SCALE DRAWING	COMMENTS:			A	TE-18006	
							SCALE: 1:16	WEIGHT:	SHEET 1 OF 1

2

1

B

2

1

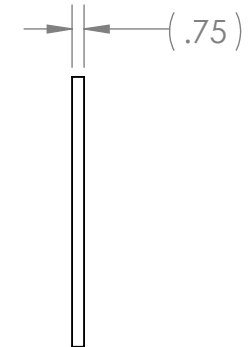
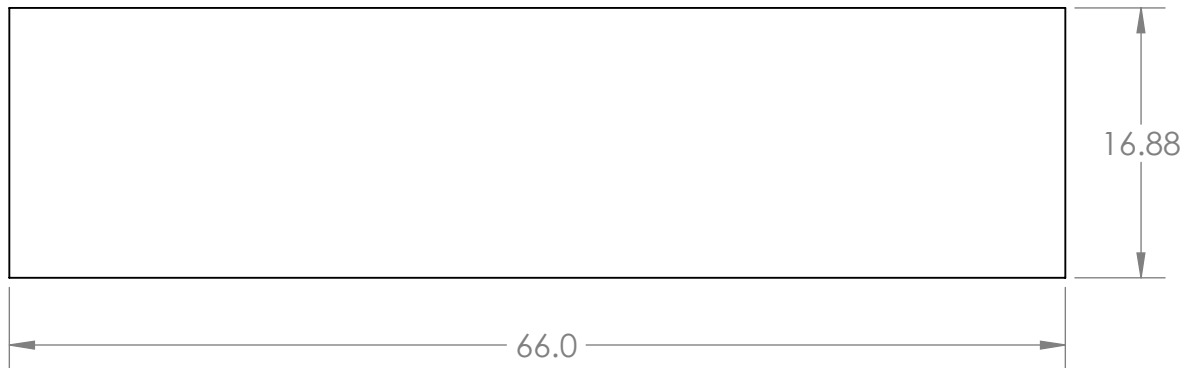



Notes:

1. Material: 3/4" AC Plywood
2. QTY. Needed: 1

A

A

PROPRIETARY AND CONFIDENTIAL THE INFORMATION CONTAINED IN THIS DRAWING IS THE SOLE PROPERTY OF FIRST® . Any REPRODUCTION IN PART OR AS A WHOLE WITHOUT THE WRITTEN PERMISSION OF FIRST® IS PROHIBITED.			UNLESS OTHERWISE SPECIFIED:		NAME	DATE	 			
			DIMENSIONS ARE IN INCHES	DRAWN				TITLE:		
			TOLERANCES:	CHECKED						
			FRACTIONAL $\pm 1/16$	ENG APPR.						
			ANGULAR: MACH $\pm 1^\circ$ BEND $\pm 1^\circ$	MFG APPR.						
		TWO PLACE DECIMAL $\pm .01$	Q.A.							
		THREE PLACE DECIMAL $\pm .001$	INTERPRET GEOMETRIC TOLERANCING PER:	COMMENTS:						
		MATERIAL	.75 Ply					SIZE	DWG. NO.	REV
		FINISH						A	TE-18006-01	
	NEXT ASSY	USED ON	DO NOT SCALE DRAWING			SCALE: 1:12	WEIGHT:	SHEET 1 OF 1		

2

1

B

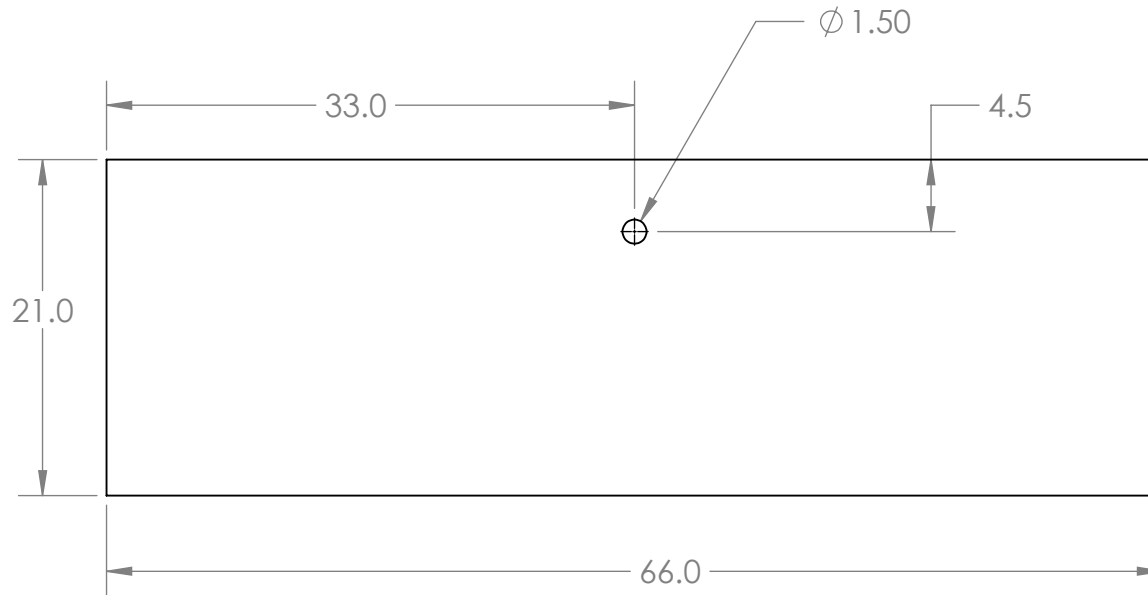



B

Notes:

1. Material: 3/4" AC Plywood
2. QTY. Needed: 2

A

A

PROPRIETARY AND CONFIDENTIAL THE INFORMATION CONTAINED IN THIS DRAWING IS THE SOLE PROPERTY OF FIRST® . Any REPRODUCTION IN PART OR AS A WHOLE WITHOUT THE WRITTEN PERMISSION OF FIRST® IS PROHIBITED.			UNLESS OTHERWISE SPECIFIED:		NAME	DATE	 	
			DIMENSIONS ARE IN INCHES	DRAWN				TITLE:
			TOLERANCES:	CHECKED				
			FRACTIONAL $\pm 1/16$	ENG APPR.				
			ANGULAR: MACH $\pm 1^\circ$ BEND $\pm 1^\circ$	MFG APPR.				
		TWO PLACE DECIMAL $\pm .01$	Q.A.					
		THREE PLACE DECIMAL $\pm .001$	INTERPRET GEOMETRIC TOLERANCING PER:	COMMENTS:				
		MATERIAL	.75 Ply				SIZE DWG. NO. REV	
	NEXT ASSY	USED ON	FINISH				A TE-18006-02	
	APPLICATION		DO NOT SCALE DRAWING				SCALE: 1:12 WEIGHT: SHEET 1 OF 1	

2

1

2

1

B

B



Notes:

- 1. Material: 2" x 4" Lumber
- 2. QTY. Needed: 2

A

A

PROPRIETARY AND CONFIDENTIAL
 THE INFORMATION CONTAINED IN THIS DRAWING IS THE SOLE PROPERTY OF **FIRST®**. Any REPRODUCTION IN PART OR AS A WHOLE WITHOUT THE WRITTEN PERMISSION OF **FIRST®** IS PROHIBITED.

		UNLESS OTHERWISE SPECIFIED:		NAME	DATE
		DIMENSIONS ARE IN INCHES	DRAWN		
		TOLERANCES:	CHECKED		
		FRACTIONAL ± 1/16	ENG APPR.		
		ANGULAR: MACH ± 1° BEND ± 1°	MFG APPR.		
		TWO PLACE DECIMAL ± .01	Q.A.		
		THREE PLACE DECIMAL ± .001	COMMENTS:		
		INTERPRET GEOMETRIC TOLERANCING PER:			
		MATERIAL			
		2x4			
		FINISH			
NEXT ASSY	USED ON				
APPLICATION		DO NOT SCALE DRAWING			



TITLE:		
SIZE	DWG. NO.	REV
A	TE-18006-03	
SCALE: 1:12	WEIGHT:	SHEET 1 OF 1

2

1

4

3

2

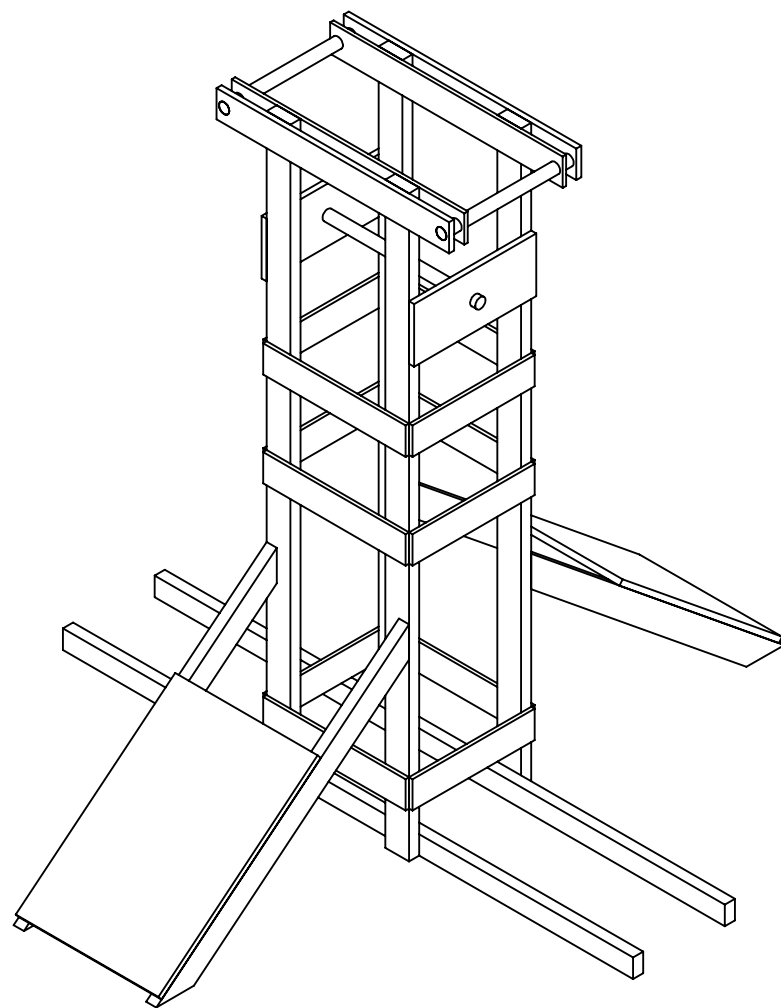

1



ITEM NO.	PART NUMBER	DESCRIPTION	QTY.
1	TE-18007-1		2
2	TE-18007-2		1
3	TE-18007-3		6
4	TE-18007-4		2
5	TE-18007-5		2
6	TE-18007-6		6
7	TE-18007-8		2
8	TE-18007-7		4
9	TE-18007-10		2
10	TE-18007-9		4
11	TE-18007-11		2

PROPRIETARY AND CONFIDENTIAL
 THE INFORMATION CONTAINED IN THIS DRAWING IS THE SOLE PROPERTY OF <INSERT COMPANY NAME HERE>. ANY REPRODUCTION IN PART OR AS A WHOLE WITHOUT THE WRITTEN PERMISSION OF <INSERT COMPANY NAME HERE> IS PROHIBITED.

		UNLESS OTHERWISE SPECIFIED:	NAME	DATE
		DIMENSIONS ARE IN INCHES TOLERANCES: FRACTIONAL $\pm 1/16$ ANGULAR: MACH $\pm 1^\circ$ BEND $\pm 1^\circ$ TWO PLACE DECIMAL $\pm .01$ THREE PLACE DECIMAL $\pm .001$	DRAWN	
		INTERPRET GEOMETRIC TOLERANCING PER:	CHECKED	
		MATERIAL	ENG APPR.	
NEXT ASSY	USED ON	FINISH	MFG APPR.	
APPLICATION		DO NOT SCALE DRAWING	Q.A.	
			COMMENTS:	

TITLE:

Scale Frame

SIZE	DWG. NO.	REV
B	TE-18007	
SCALE: 1:20 WEIGHT:		SHEET 1 OF 3

4

3

2

1

B

B

A

A

4

3

2

1

B

B

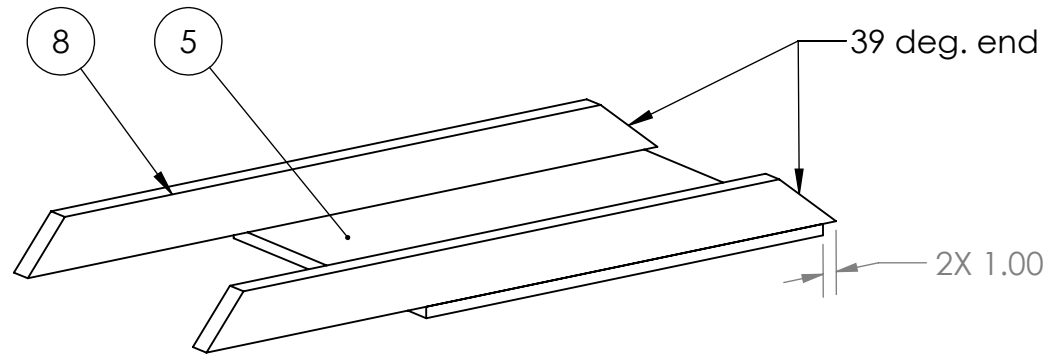

Step 1: Attach as shown with wood screws. Build qty. 2.

Only attach with 2 screws until final assembly.

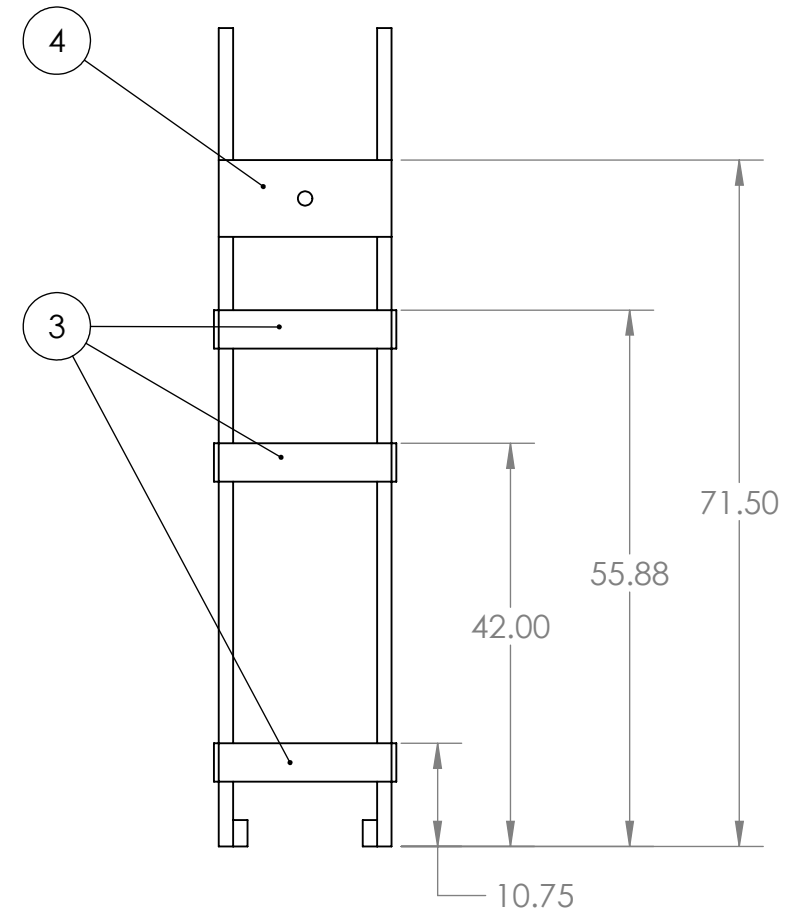
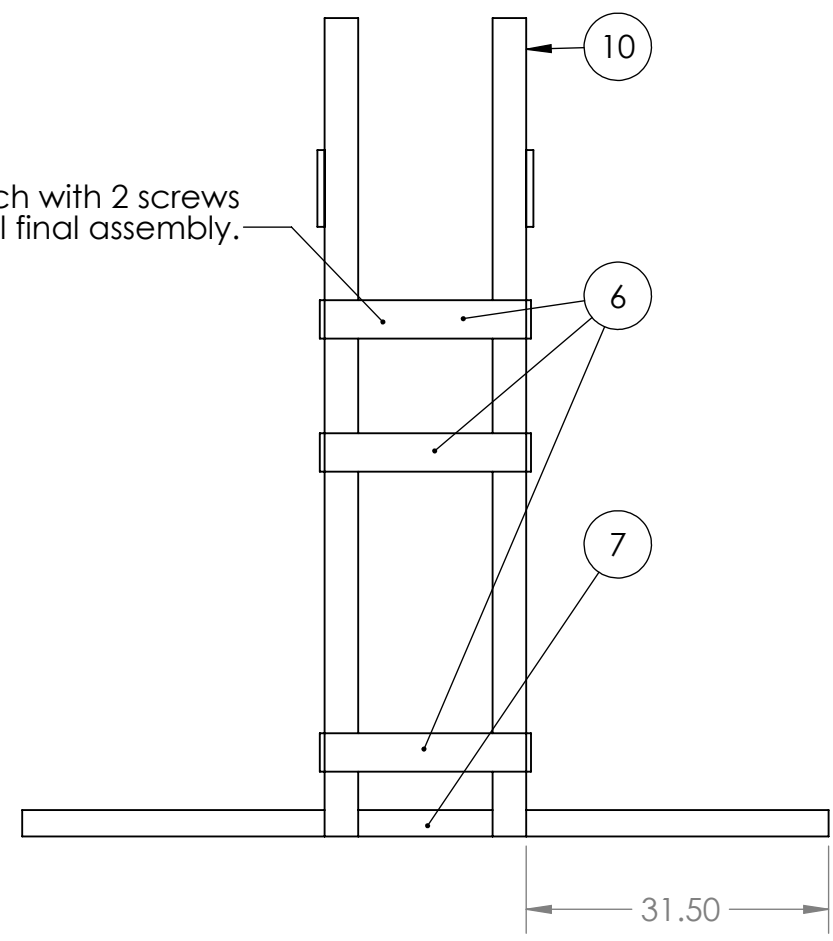



Step 2: Attach as shown with wood screws. Use wooden dowel to help align Item 4 (qty. 2).

A

A

PROPRIETARY AND CONFIDENTIAL
 THE INFORMATION CONTAINED IN THIS DRAWING IS THE SOLE PROPERTY OF <INSERT COMPANY NAME HERE>. ANY REPRODUCTION IN PART OR AS A WHOLE WITHOUT THE WRITTEN PERMISSION OF <INSERT COMPANY NAME HERE> IS PROHIBITED.

		UNLESS OTHERWISE SPECIFIED:		NAME	DATE
		DIMENSIONS ARE IN INCHES		DRAWN	
		TOLERANCES:		CHECKED	
		FRACTIONAL ±1/16		ENG APPR.	
		ANGULAR: MACH ±1° BEND ±1°		MFG APPR.	
		TWO PLACE DECIMAL ±.01		Q.A.	
		THREE PLACE DECIMAL ±.001		COMMENTS:	
		INTERPRET GEOMETRIC TOLERANCING PER:			
		MATERIAL			
NEXT ASSY	USED ON	FINISH			
APPLICATION		DO NOT SCALE DRAWING			
				 	
				TITLE: Scale Frame	
SIZE	DWG. NO.			REV	
B	TE-18007				
SCALE: 1:32			WEIGHT:	SHEET 2 OF 3	

4

3

2

1

4

3

2

1

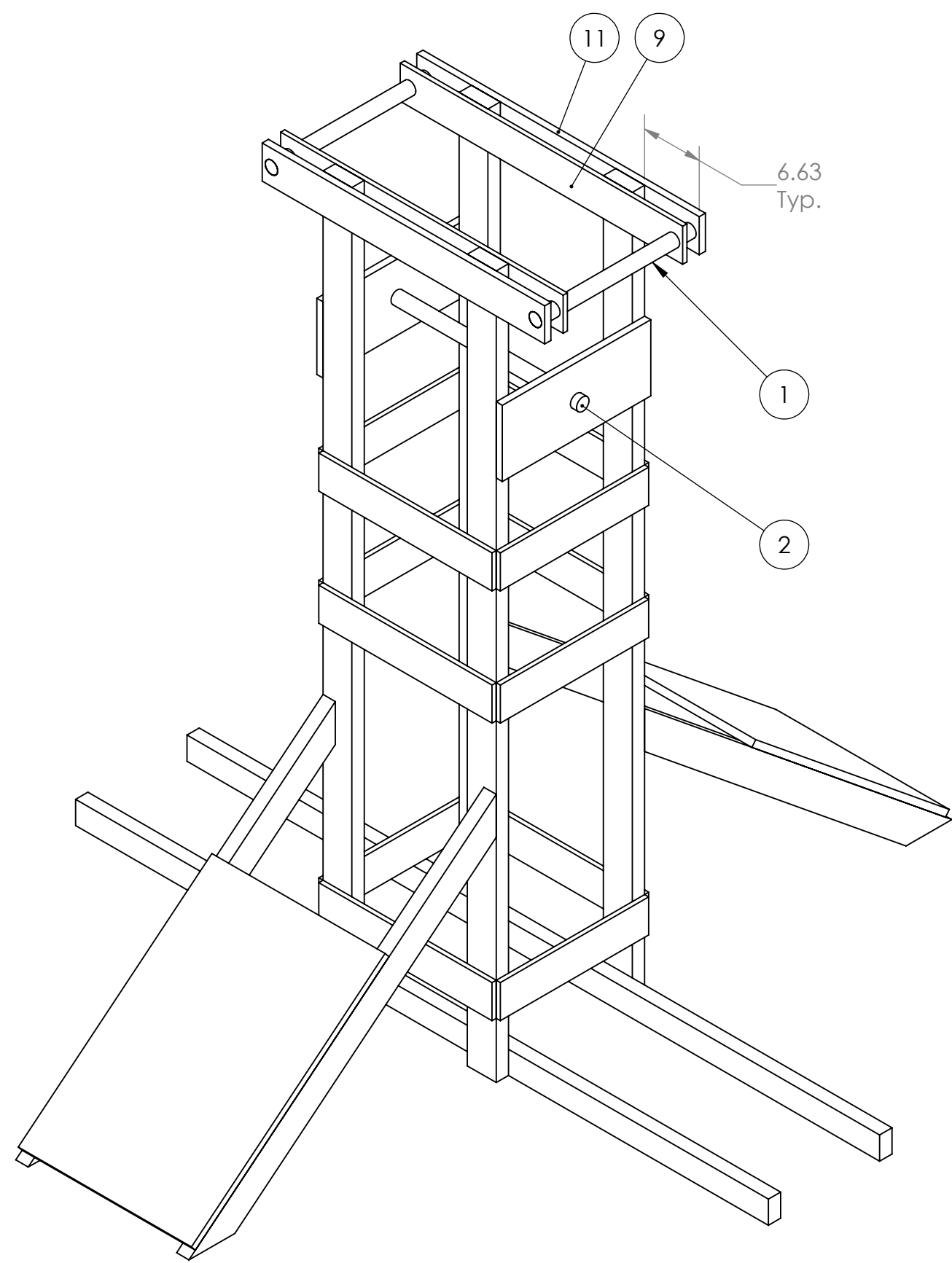

Step 3: Attach two assemblies from Step 1 to the main assembly. When attaching items 1, 9 and 11, ensure that dowel is level and the top surface is 84" from the ground. Use wood screws to keep dowel from rotating.

Do not fasten Item 2.



B

B

A

A

PROPRIETARY AND CONFIDENTIAL
 THE INFORMATION CONTAINED IN THIS DRAWING IS THE SOLE PROPERTY OF <INSERT COMPANY NAME HERE>. ANY REPRODUCTION IN PART OR AS A WHOLE WITHOUT THE WRITTEN PERMISSION OF <INSERT COMPANY NAME HERE> IS PROHIBITED.

		UNLESS OTHERWISE SPECIFIED:	NAME	DATE	 
		DIMENSIONS ARE IN INCHES TOLERANCES: FRACTIONAL ±1/16 ANGULAR: MACH ±1° BEND ±1° TWO PLACE DECIMAL ±.01 THREE PLACE DECIMAL ±.001	DRAWN		
		INTERPRET GEOMETRIC TOLERANCING PER:	CHECKED		SIZE DWG. NO. REV B TE-18007
		MATERIAL	ENG APPR.		
NEXT ASSY	USED ON	FINISH	MFG APPR.		SCALE: 1:32 WEIGHT: SHEET 3 OF 3
APPLICATION		DO NOT SCALE DRAWING	Q.A.	COMMENTS:	

4

3

2

1

2

1

B

B

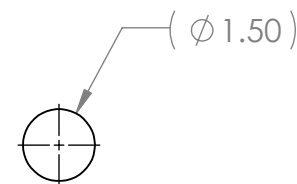
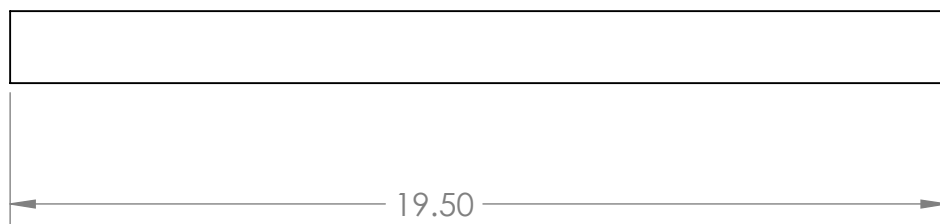

- Notes:
1. Material: 1.5" dowel rod
 2. QTY. Needed: 2

A

A

PROPRIETARY AND CONFIDENTIAL
 THE INFORMATION CONTAINED IN THIS DRAWING IS THE SOLE PROPERTY OF **FIRST®**. Any REPRODUCTION IN PART OR AS A WHOLE WITHOUT THE WRITTEN PERMISSION OF **FIRST®** IS PROHIBITED.

		UNLESS OTHERWISE SPECIFIED:		NAME	DATE
		DIMENSIONS ARE IN INCHES	DRAWN		
		TOLERANCES:	CHECKED		
		FRACTIONAL ± 1/16	ENG APPR.		
		ANGULAR: MACH ± 1° BEND ± 1°	MFG APPR.		
		TWO PLACE DECIMAL ± .01	Q.A.		
		THREE PLACE DECIMAL ± .001	COMMENTS:		
		INTERPRET GEOMETRIC TOLERANCING PER:			
		MATERIAL			
		FINISH			
NEXT ASSY	USED ON				
APPLICATION		DO NOT SCALE DRAWING			



TITLE:		
SIZE	DWG. NO.	REV
A	TE-18007-1	
SCALE: 1:4	WEIGHT:	SHEET 1 OF 1

2

1

2

1

B

B

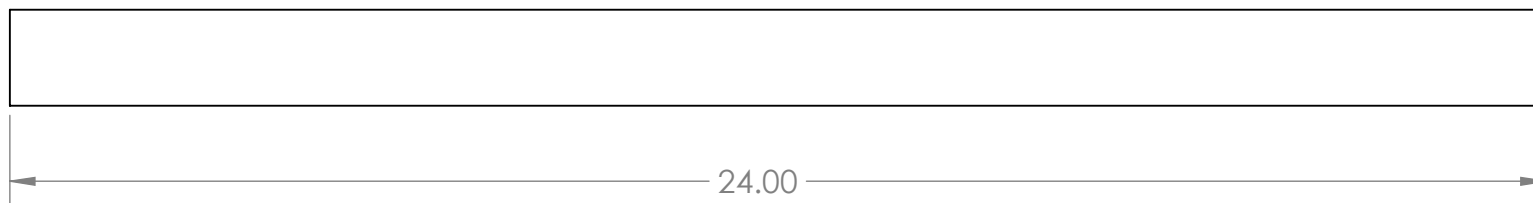

- Notes:
1. Material: 1.5" dowel rod
 2. QTY. Needed: 1

A

A

PROPRIETARY AND CONFIDENTIAL
 THE INFORMATION CONTAINED IN THIS DRAWING IS THE SOLE PROPERTY OF **FIRST®**. Any REPRODUCTION IN PART OR AS A WHOLE WITHOUT THE WRITTEN PERMISSION OF **FIRST®** IS PROHIBITED.

		UNLESS OTHERWISE SPECIFIED:		NAME	DATE
		DIMENSIONS ARE IN INCHES	DRAWN		
		TOLERANCES:	CHECKED		
		FRACTIONAL ± 1/16	ENG APPR.		
		ANGULAR: MACH ± 1° BEND ± 1°	MFG APPR.		
		TWO PLACE DECIMAL ± .01	Q.A.		
		THREE PLACE DECIMAL ± .001	COMMENTS:		
		INTERPRET GEOMETRIC TOLERANCING PER:			
		MATERIAL			
		FINISH			
NEXT ASSY	USED ON				
APPLICATION		DO NOT SCALE DRAWING			



TITLE:		
SIZE	DWG. NO.	REV
A	TE-18007-2	
SCALE: 1:3	WEIGHT:	SHEET 1 OF 1

2

1

B

2

1

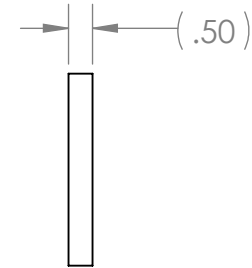
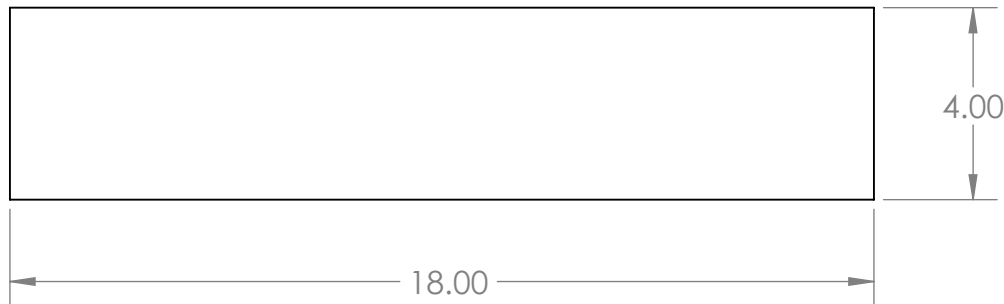



B

Notes:

1. Material: 1/2" AC Plywood
2. QTY. Needed: 6

A

A

PROPRIETARY AND CONFIDENTIAL THE INFORMATION CONTAINED IN THIS DRAWING IS THE SOLE PROPERTY OF FIRST® . Any REPRODUCTION IN PART OR AS A WHOLE WITHOUT THE WRITTEN PERMISSION OF FIRST® IS PROHIBITED.			UNLESS OTHERWISE SPECIFIED:		NAME	DATE	 	
			DIMENSIONS ARE IN INCHES	DRAWN				TITLE:
			TOLERANCES:	CHECKED				
			FRACTIONAL $\pm 1/16$	ENG APPR.				
			ANGULAR: MACH $\pm 1^\circ$ BEND $\pm 1^\circ$	MFG APPR.				
		TWO PLACE DECIMAL $\pm .01$	Q.A.					
		THREE PLACE DECIMAL $\pm .001$	INTERPRET GEOMETRIC TOLERANCING PER:	COMMENTS:				
		MATERIAL						
		FINISH						
	NEXT ASSY	USED ON	APPLICATION	DO NOT SCALE DRAWING	SIZE	DWG. NO.	REV	
					A	TE-18007-3		
					SCALE: 1:4	WEIGHT:	SHEET 1 OF 1	

2

1

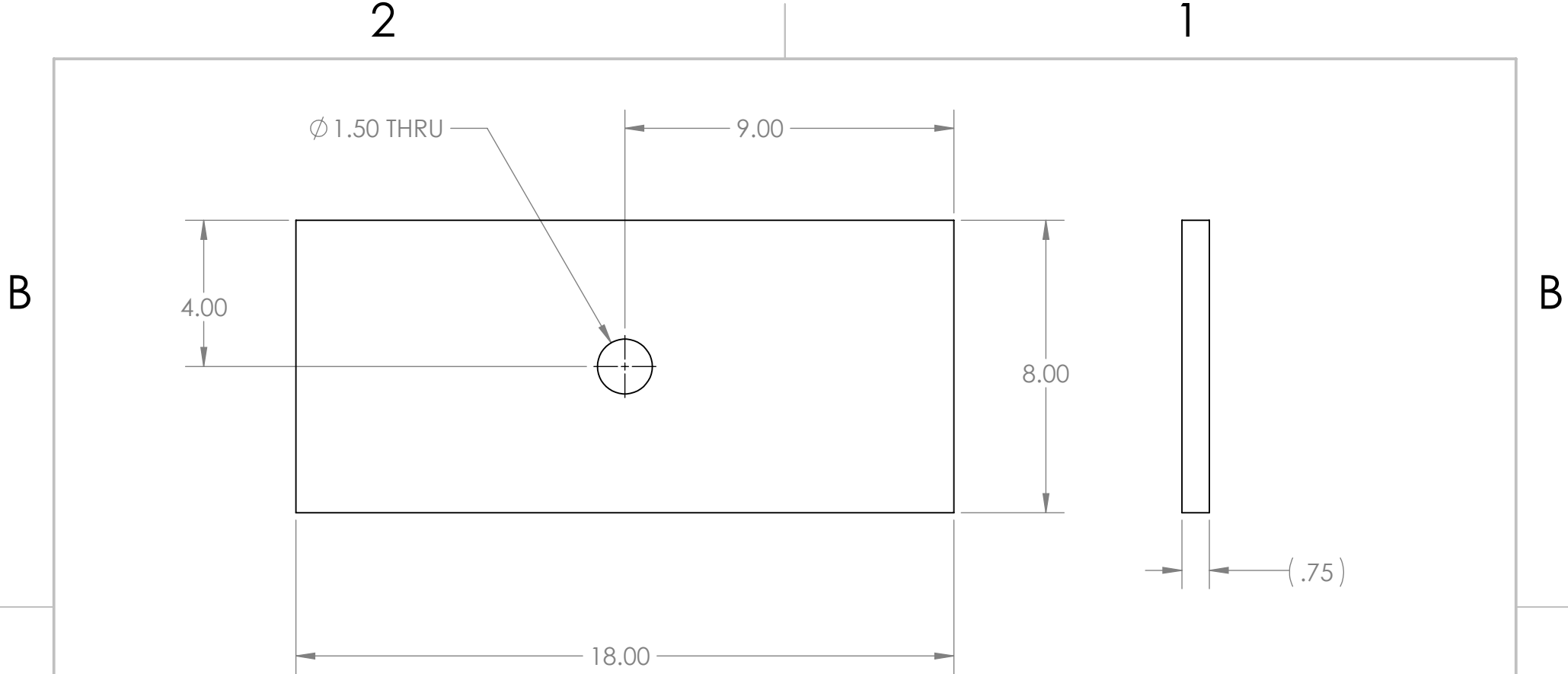

Notes:

1. Material: 3/4" AC Plywood
2. QTY. Needed: 2

PROPRIETARY AND CONFIDENTIAL
 THE INFORMATION CONTAINED IN THIS DRAWING IS THE SOLE PROPERTY OF **FIRST®**. Any REPRODUCTION IN PART OR AS A WHOLE WITHOUT THE WRITTEN PERMISSION OF **FIRST®** IS PROHIBITED.



		UNLESS OTHERWISE SPECIFIED:		NAME	DATE
		DIMENSIONS ARE IN INCHES	DRAWN		
		TOLERANCES:	CHECKED		
		FRACTIONAL ± 1/16	ENG APPR.		
		ANGULAR: MACH ± 1° BEND ± 1°	MFG APPR.		
		TWO PLACE DECIMAL ± .01	Q.A.		
		THREE PLACE DECIMAL ± .001	COMMENTS:		
		INTERPRET GEOMETRIC TOLERANCING PER:			
		MATERIAL			
NEXT ASSY	USED ON	FINISH			
APPLICATION		DO NOT SCALE DRAWING			

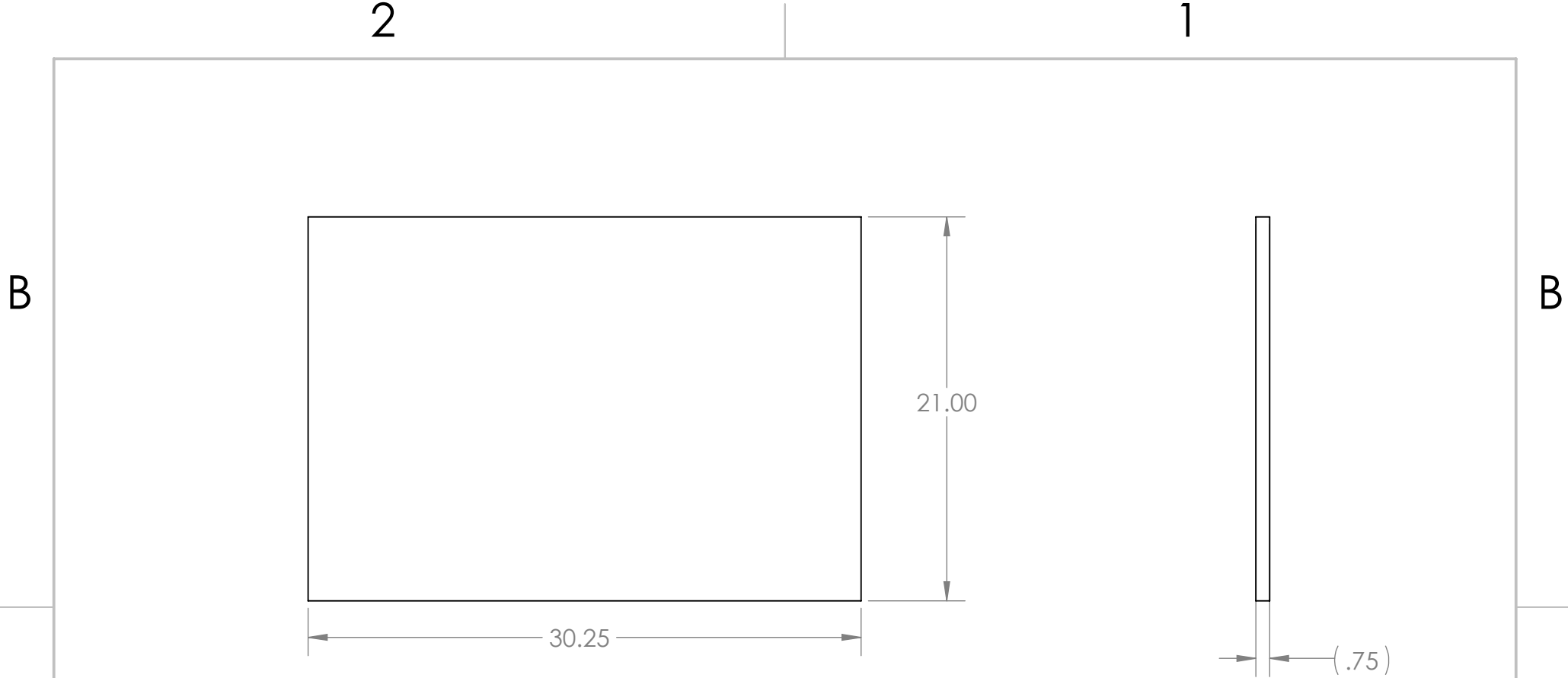

TITLE:		
SIZE	DWG. NO.	REV
A	TE-18007-4	
SCALE: 1:4	WEIGHT:	SHEET 1 OF 1



- Notes:
1. Material: 3/4" AC Plywood
 2. QTY. Needed: 2

<p>PROPRIETARY AND CONFIDENTIAL</p> <p>THE INFORMATION CONTAINED IN THIS DRAWING IS THE SOLE PROPERTY OF FIRST®. Any REPRODUCTION IN PART OR AS A WHOLE WITHOUT THE WRITTEN PERMISSION OF FIRST® IS PROHIBITED.</p>			UNLESS OTHERWISE SPECIFIED:		NAME	DATE	 		
			DIMENSIONS ARE IN INCHES	DRAWN				TITLE:	
			TOLERANCES:	CHECKED					
			FRACTIONAL $\pm 1/16$	ENG APPR.					
			ANGULAR: MACH $\pm 1^\circ$ BEND $\pm 1^\circ$	MFG APPR.					
		TWO PLACE DECIMAL $\pm .01$	Q.A.						
		THREE PLACE DECIMAL $\pm .001$	COMMENTS:						
		INTERPRET GEOMETRIC TOLERANCING PER:	MATERIAL				SIZE	DWG. NO.	REV
			FINISH				A	TE-18007-5	
	NEXT ASSY	USED ON					SCALE: 1:8	WEIGHT:	SHEET 1 OF 1
	APPLICATION		DO NOT SCALE DRAWING						

B

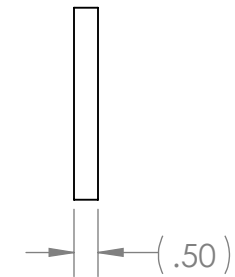
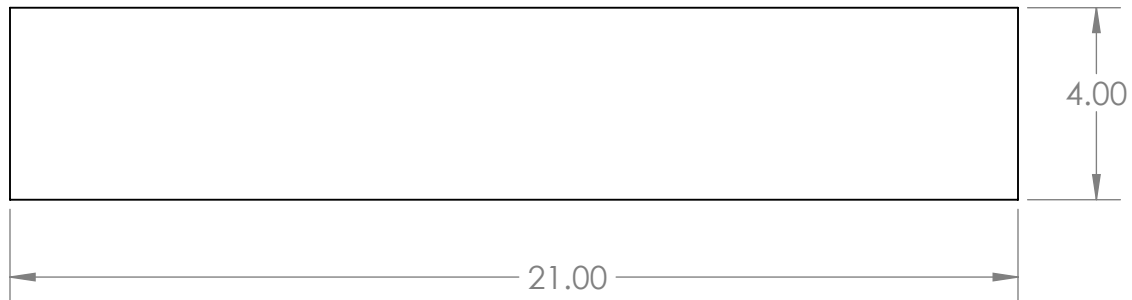



Notes:

1. Material: 1/2" AC Plywood
2. QTY. Needed: 6

A

A

PROPRIETARY AND CONFIDENTIAL
 THE INFORMATION CONTAINED IN THIS DRAWING IS THE SOLE PROPERTY OF **FIRST®**. Any REPRODUCTION IN PART OR AS A WHOLE WITHOUT THE WRITTEN PERMISSION OF **FIRST®** IS PROHIBITED.

		UNLESS OTHERWISE SPECIFIED:	NAME	DATE	 		
		DIMENSIONS ARE IN INCHES	DRAWN		TITLE:		
		TOLERANCES:	CHECKED				
		FRACTIONAL $\pm 1/16$	ENG APPR.				
		ANGULAR: MACH $\pm 1^\circ$ BEND $\pm 1^\circ$	MFG APPR.				
		TWO PLACE DECIMAL $\pm .01$	Q.A.				
		THREE PLACE DECIMAL $\pm .001$	COMMENTS:				
		INTERPRET GEOMETRIC TOLERANCING PER:			SIZE	DWG. NO.	REV
		MATERIAL			A	TE-18007-6	
NEXT ASSY	USED ON	FINISH			SCALE: 1:4	WEIGHT:	SHEET 1 OF 1
APPLICATION		DO NOT SCALE DRAWING					

2

1

2

1

B

B

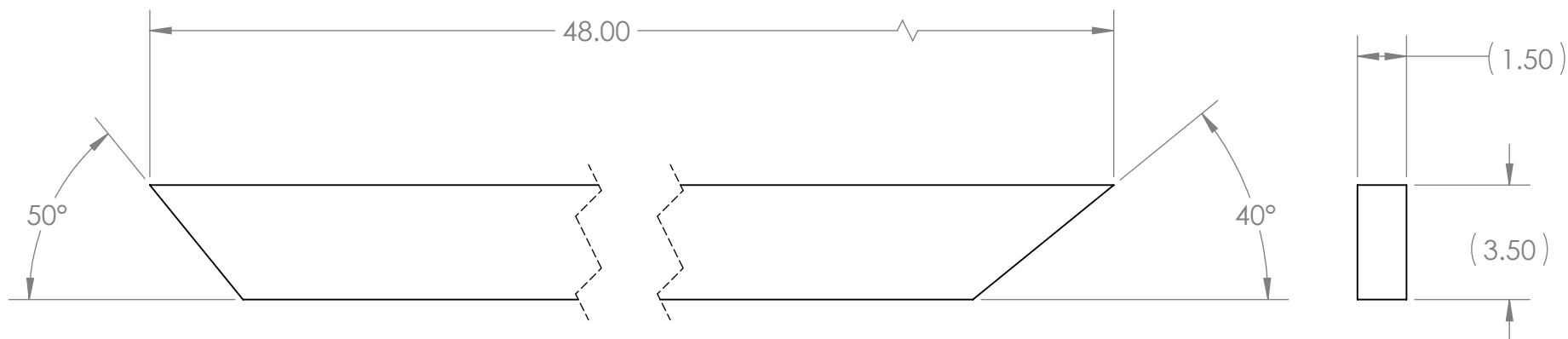

Notes:

- 1. Material: 2" x 4" Pine Lumber
- 2. QTY. Needed: 4

A

A

PROPRIETARY AND CONFIDENTIAL
 THE INFORMATION CONTAINED IN THIS DRAWING IS THE SOLE PROPERTY OF **FIRST®**. Any REPRODUCTION IN PART OR AS A WHOLE WITHOUT THE WRITTEN PERMISSION OF **FIRST®** IS PROHIBITED.

		UNLESS OTHERWISE SPECIFIED:		NAME	DATE
		DIMENSIONS ARE IN INCHES	DRAWN		
		TOLERANCES:	CHECKED		
		FRACTIONAL ± 1/16	ENG APPR.		
		ANGULAR: MACH ± 1° BEND ± 1°	MFG APPR.		
		TWO PLACE DECIMAL ± .01	Q.A.		
		THREE PLACE DECIMAL ± .001	COMMENTS:		
		INTERPRET GEOMETRIC TOLERANCING PER:			
		MATERIAL			
		FINISH			
NEXT ASSY	USED ON				
APPLICATION		DO NOT SCALE DRAWING			



TITLE:		
SIZE	DWG. NO.	REV
A	TE-18007-7	
SCALE: 1:5	WEIGHT:	SHEET 1 OF 1

2

1

2

1

B

B

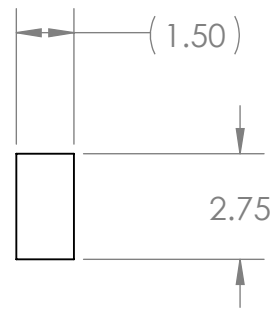
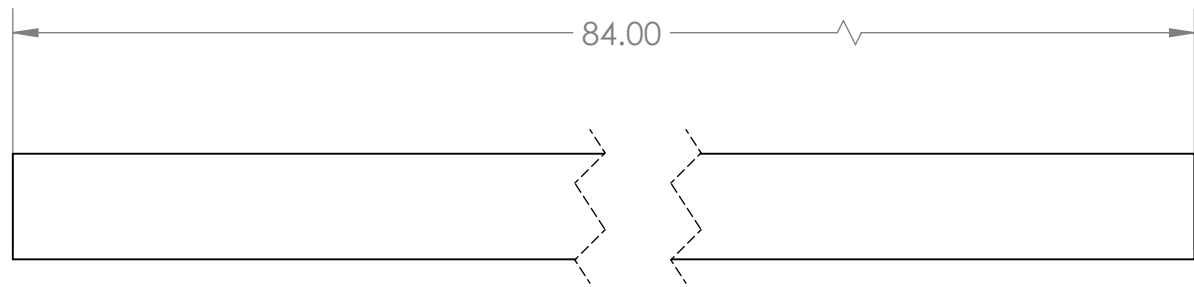

Notes:

- 1. Material: 2" x 4" Pine Lumber
- 2. QTY. Needed: 2

A

A

PROPRIETARY AND CONFIDENTIAL
 THE INFORMATION CONTAINED IN THIS DRAWING IS THE SOLE PROPERTY OF **FIRST®**. Any REPRODUCTION IN PART OR AS A WHOLE WITHOUT THE WRITTEN PERMISSION OF **FIRST®** IS PROHIBITED.

		UNLESS OTHERWISE SPECIFIED:		NAME	DATE
		DIMENSIONS ARE IN INCHES	DRAWN		
		TOLERANCES:	CHECKED		
		FRACTIONAL ± 1/16	ENG APPR.		
		ANGULAR: MACH ± 1° BEND ± 1°	MFG APPR.		
		TWO PLACE DECIMAL ± .01	Q.A.		
		THREE PLACE DECIMAL ± .001	COMMENTS:		
		INTERPRET GEOMETRIC TOLERANCING PER:			
		MATERIAL			
		FINISH			
NEXT ASSY	USED ON				
APPLICATION		DO NOT SCALE DRAWING			



TITLE:		
SIZE	DWG. NO.	REV
A	TE-18007-8	
SCALE: 1:5	WEIGHT:	SHEET 1 OF 1

2

1

2

1

B

B

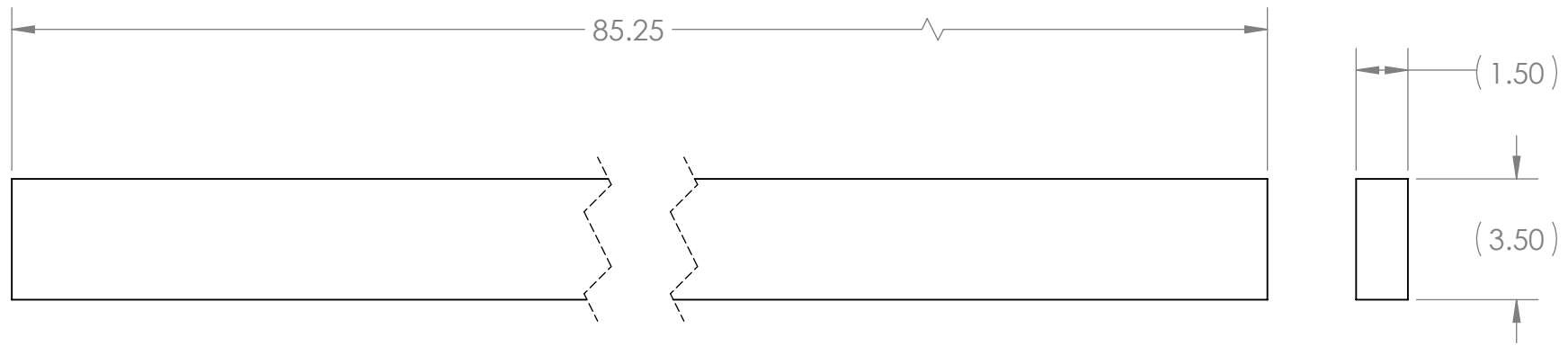

Notes:



- 1. Material: 2" x 4" Pine Lumber
- 2. QTY. Needed: 4

A

A

PROPRIETARY AND CONFIDENTIAL
 THE INFORMATION CONTAINED IN THIS DRAWING IS THE SOLE PROPERTY OF **FIRST®**. Any REPRODUCTION IN PART OR AS A WHOLE WITHOUT THE WRITTEN PERMISSION OF **FIRST®** IS PROHIBITED.

		UNLESS OTHERWISE SPECIFIED:		NAME	DATE
		DIMENSIONS ARE IN INCHES	DRAWN		
		TOLERANCES:	CHECKED		
		FRACTIONAL ± 1/16	ENG APPR.		
		ANGULAR: MACH ± 1° BEND ± 1°	MFG APPR.		
		TWO PLACE DECIMAL ± .01	Q.A.		
		THREE PLACE DECIMAL ± .001	COMMENTS:		
		INTERPRET GEOMETRIC TOLERANCING PER:			
		MATERIAL			
NEXT ASSY	USED ON	FINISH			
APPLICATION		DO NOT SCALE DRAWING			





TITLE:

SIZE	DWG. NO.	REV
A	TE-18007-9	
SCALE: 1:5	WEIGHT:	SHEET 1 OF 1

2

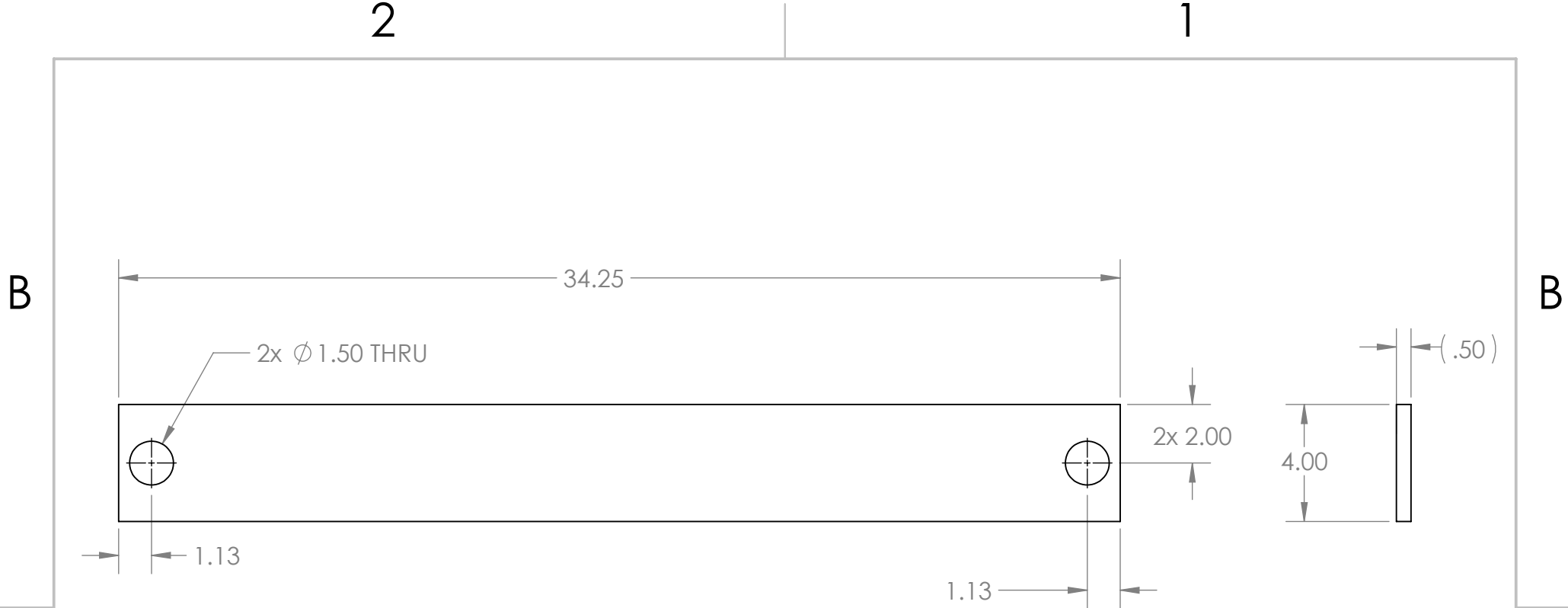
1



Notes:

1. Material: 1/2" AC Plywood
2. QTY. Needed: 2

PROPRIETARY AND CONFIDENTIAL
 THE INFORMATION CONTAINED IN THIS DRAWING IS THE SOLE PROPERTY OF **FIRST®**. Any REPRODUCTION IN PART OR AS A WHOLE WITHOUT THE WRITTEN PERMISSION OF **FIRST®** IS PROHIBITED.

		UNLESS OTHERWISE SPECIFIED:	NAME	DATE
		DIMENSIONS ARE IN INCHES	DRAWN	
		TOLERANCES:	CHECKED	
		FRACTIONAL $\pm 1/16$	ENG APPR.	
		ANGULAR: MACH $\pm 1^\circ$ BEND $\pm 1^\circ$	MFG APPR.	
		TWO PLACE DECIMAL $\pm .01$	Q.A.	
		THREE PLACE DECIMAL $\pm .001$	COMMENTS:	
		INTERPRET GEOMETRIC TOLERANCING PER:		
		MATERIAL		
NEXT ASSY	USED ON	FINISH		
APPLICATION		DO NOT SCALE DRAWING		



TITLE:		
SIZE	DWG. NO.	REV
A	TE-18007-10	
SCALE: 1:5	WEIGHT:	SHEET 1 OF 1



Notes:

1. Material: 3/4" AC Plywood
2. QTY. Needed: 2

PROPRIETARY AND CONFIDENTIAL
 THE INFORMATION CONTAINED IN THIS DRAWING IS THE SOLE PROPERTY OF **FIRST®**. Any REPRODUCTION IN PART OR AS A WHOLE WITHOUT THE WRITTEN PERMISSION OF **FIRST®** IS PROHIBITED.

		UNLESS OTHERWISE SPECIFIED:		NAME	DATE
		DIMENSIONS ARE IN INCHES	DRAWN		
		TOLERANCES:	CHECKED		
		FRACTIONAL $\pm 1/16$	ENG APPR.		
		ANGULAR: MACH $\pm 1^\circ$ BEND $\pm 1^\circ$	MFG APPR.		
		TWO PLACE DECIMAL $\pm .01$	Q.A.		
		THREE PLACE DECIMAL $\pm .001$	COMMENTS:		
		INTERPRET GEOMETRIC TOLERANCING PER:			
		MATERIAL			
		FINISH			
NEXT ASSY	USED ON				
APPLICATION		DO NOT SCALE DRAWING			



TITLE:		
SIZE	DWG. NO.	REV
A	TE-18007-11	
SCALE: 1:5	WEIGHT:	SHEET 1 OF 1

4

3

2

1

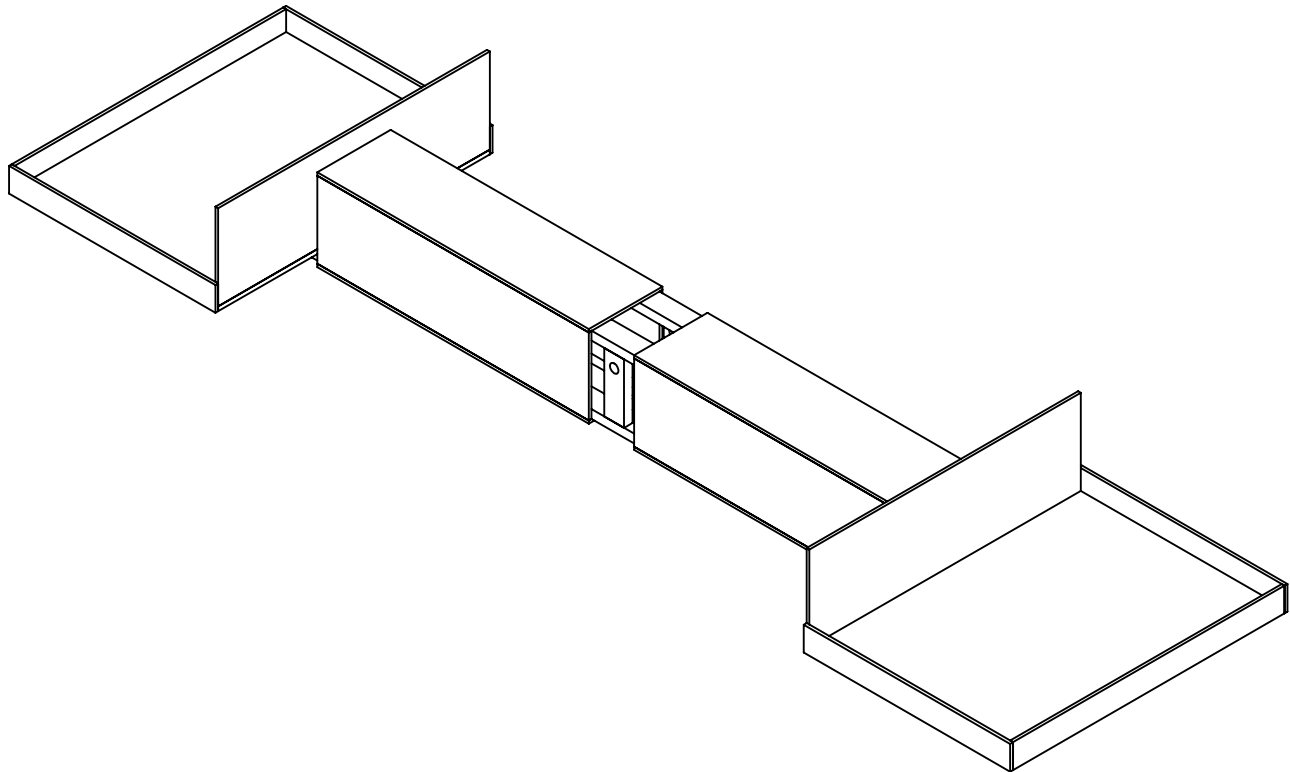

ITEM NO.	PART NUMBER	DESCRIPTION	QTY.
1	TE-18008-07		2
2	TE-18008-08		2
3	TE-18008-04		2
4	TE-18008-01		4
5	TE-18008-05		2
6	TE-18008-06		4
7	TE-18008-02		4
8	TE-18008-11		2
9	TE-18008-03		2
10	TE-18008-09		4
11	TE-18008-10		2

B

B

A

A

PROPRIETARY AND CONFIDENTIAL
 THE INFORMATION CONTAINED IN THIS DRAWING IS THE SOLE PROPERTY OF **FIRST®**. Any REPRODUCTION IN PART OR AS A WHOLE WITHOUT THE WRITTEN PERMISSION OF **FIRST®** IS PROHIBITED.

UNLESS OTHERWISE SPECIFIED:		NAME	DATE
DIMENSIONS ARE IN INCHES		DRAWN	
TOLERANCES:		CHECKED	
FRACTIONAL ±1/16		ENG APPR.	
ANGULAR: MACH ±1° BEND ±1°		MFG APPR.	
TWO PLACE DECIMAL ±.01		Q.A.	
THREE PLACE DECIMAL ±.001		COMMENTS:	
INTERPRET GEOMETRIC TOLERANCING PER:			
MATERIAL			
NEXT ASSY	USED ON		
FINISH			
APPLICATION			
DO NOT SCALE DRAWING			



TITLE: **Scale Arm**

SIZE DWG. NO. REV
B **TE-18008**

SCALE: 1:32 WEIGHT: SHEET 1 OF 3

4

3

2

1

4

3

2

1

B

B

A

A

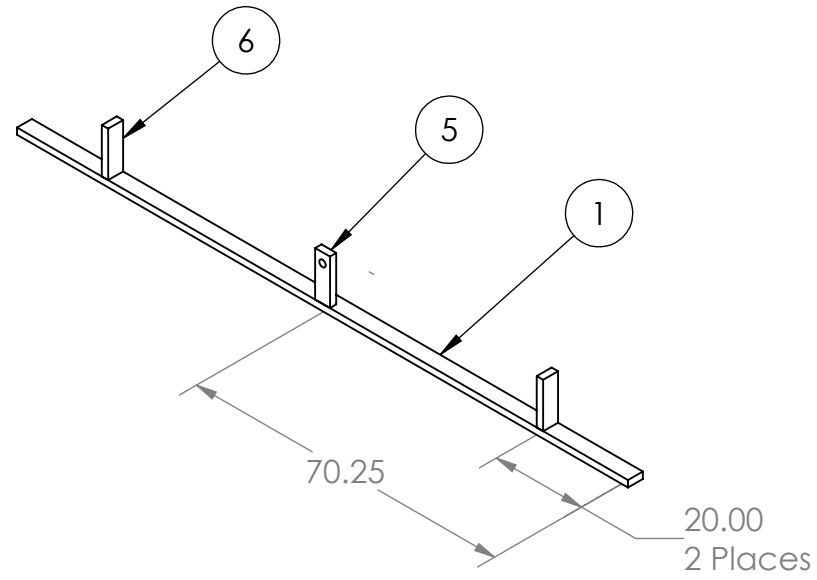

Step 1: Attach Item 6 (qty. 2) and Item 5 to Item 1 as shown using wood screws. Build 2 identical assemblies.

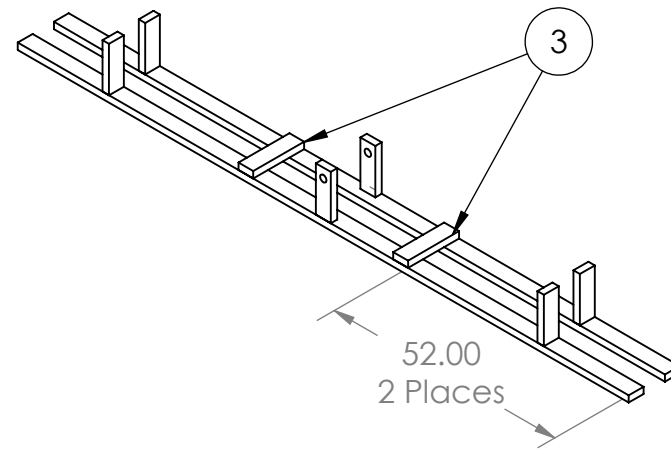

Step 2: Attach Item 3 (qty. 2) to the two assemblies from Step 1 using wood screws.

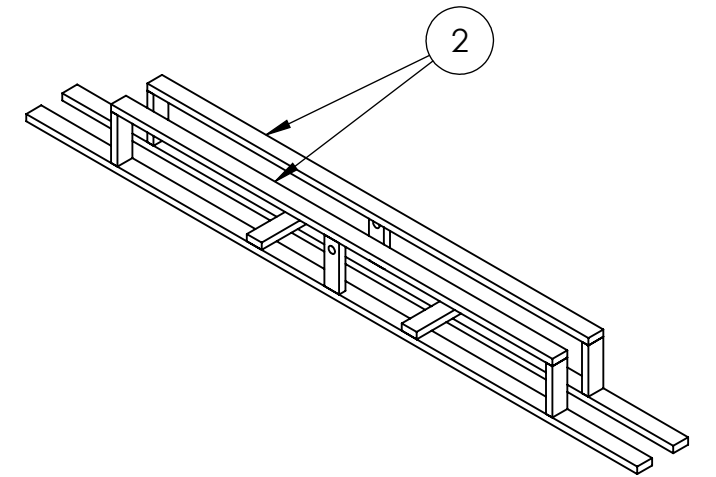

Step 3: Attach Item 2 (qty. 2) as shown using wood screws.

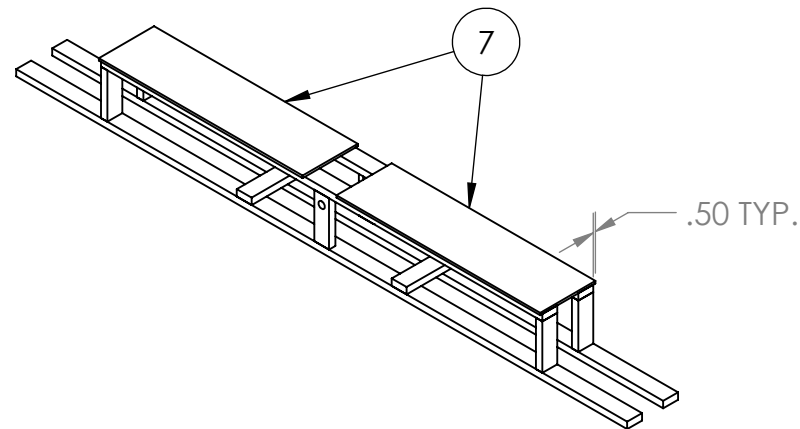

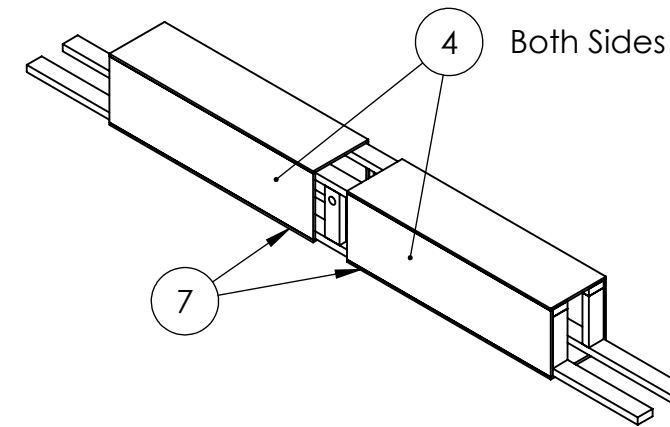

Step 4: Attach Item 7 (qty. 2) as shown using wood screws. There should be a 1/2" overhang on each side.



Step 5: Attach Item 4 (qty. 4) and as shown using wood screws. Flip assembly over and attach Item 7 (qty. 2).

PROPRIETARY AND CONFIDENTIAL
THE INFORMATION CONTAINED IN THIS DRAWING IS THE SOLE PROPERTY OF **FIRST®**. Any REPRODUCTION IN PART OR AS A WHOLE WITHOUT THE WRITTEN PERMISSION OF **FIRST®** IS PROHIBITED.

		UNLESS OTHERWISE SPECIFIED:		NAME	DATE
		DIMENSIONS ARE IN INCHES		DRAWN	
		TOLERANCES:		CHECKED	
		FRACTIONAL ±1/16		ENG APPR.	
		ANGULAR: MACH ±1° BEND ±1°		MFG APPR.	
		TWO PLACE DECIMAL ±.01		Q.A.	
		THREE PLACE DECIMAL ±.001		COMMENTS:	
		INTERPRET GEOMETRIC TOLERANCING PER:			
		MATERIAL			
		FINISH			
NEXT ASSY	USED ON	APPLICATION		DO NOT SCALE DRAWING	

TITLE:

Scale Arm

SIZE	DWG. NO.	REV
B	TE-18008	
SCALE: 1:32 WEIGHT:		SHEET 2 OF 3

4

3

2

1

4

3

2

1

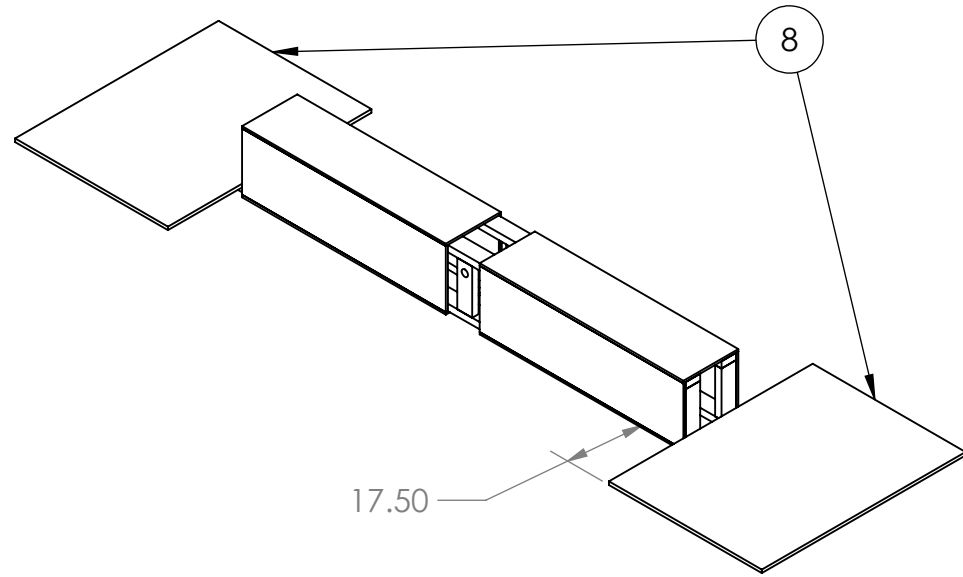

DO NOT PROCEED TO THIS STEP UNTIL YOU HAVE ASSEMBLED TO THE SCALE FRAME (See Drawing TE-18014)

Step 6: Attach Item 8 (qty. 2) as shown using wood screws.

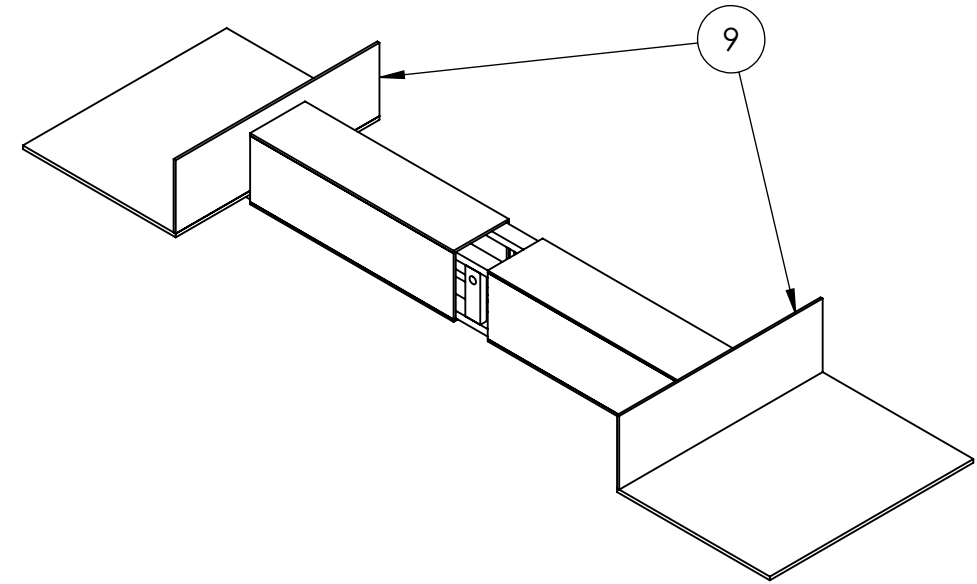

DO NOT PROCEED TO THIS STEP UNTIL YOU HAVE ASSEMBLED TO THE SCALE FRAME

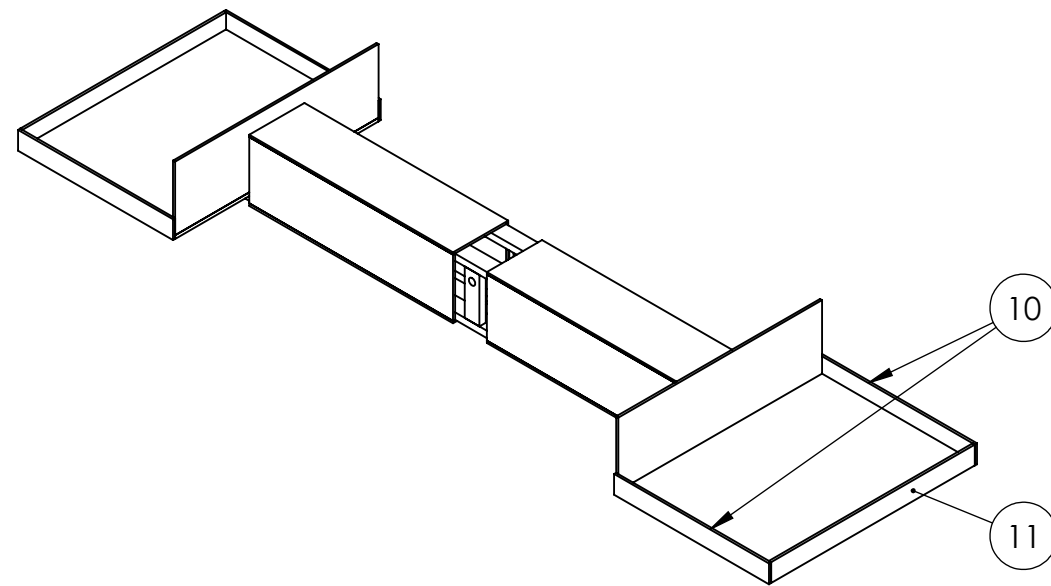

Step 7: Attach Item 9 (qty. 2) as shown using wood screws.



DO NOT PROCEED TO THIS STEP UNTIL YOU HAVE ASSEMBLED TO THE SCALE FRAME

Step 8: Attach Item 10 (qty. 4) and Item 11 (qty. 2) and as shown using wood screws or staples. Pre-drill holes to avoid splitting.

PROPRIETARY AND CONFIDENTIAL
THE INFORMATION CONTAINED IN THIS DRAWING IS THE SOLE PROPERTY OF **FIRST®**. Any REPRODUCTION IN PART OR AS A WHOLE WITHOUT THE WRITTEN PERMISSION OF **FIRST®** IS PROHIBITED.

		UNLESS OTHERWISE SPECIFIED:		NAME	DATE
		DIMENSIONS ARE IN INCHES TOLERANCES: FRACTIONAL: ±1/16 ANGULAR: MACH ±1° BEND ±1° TWO PLACE DECIMAL ±.01 THREE PLACE DECIMAL ±.001		DRAWN	
		INTERPRET GEOMETRIC TOLERANCING PER:		CHECKED	
		MATERIAL		ENG APPR.	
		FINISH		MFG APPR.	
NEXT ASSY	USED ON			Q.A.	
APPLICATION		DO NOT SCALE DRAWING		COMMENTS:	
				 	
				TITLE: Scale Arm	
SIZE	DWG. NO.			REV	
B	TE-18008				
SCALE: 1:32				WEIGHT:	SHEET 3 OF 3

4

3

2

1

B

B

A

A

2

1

B

B

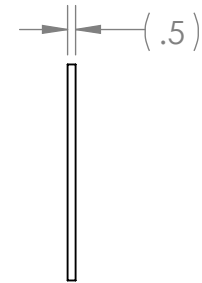
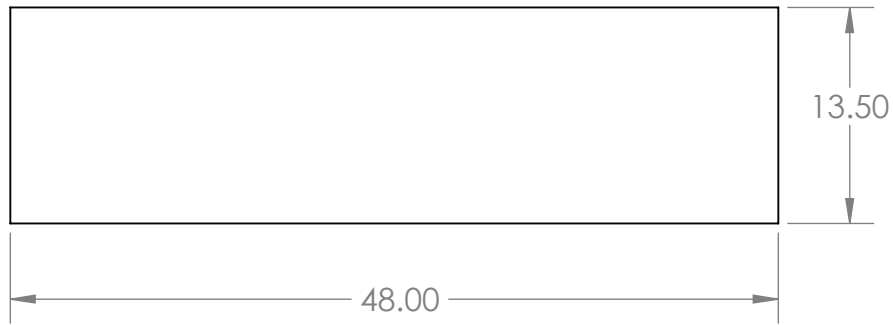

Notes:

- 1. Material: 1/2" AC Plywood
- 2. QTY. Needed: 4

A

A

PROPRIETARY AND CONFIDENTIAL
 THE INFORMATION CONTAINED IN THIS DRAWING IS THE SOLE PROPERTY OF **FIRST®**. Any REPRODUCTION IN PART OR AS A WHOLE WITHOUT THE WRITTEN PERMISSION OF **FIRST®** IS PROHIBITED.

		UNLESS OTHERWISE SPECIFIED:		NAME	DATE
		DIMENSIONS ARE IN INCHES	DRAWN		
		TOLERANCES:	CHECKED		
		FRACTIONAL ± 1/16	ENG APPR.		
		ANGULAR: MACH ± 1° BEND ± 1°	MFG APPR.		
		TWO PLACE DECIMAL ± .01	Q.A.		
		THREE PLACE DECIMAL ± .001	COMMENTS:		
		INTERPRET GEOMETRIC TOLERANCING PER:			
		MATERIAL			
		1/2" Ply			
		FINISH			
NEXT ASSY	USED ON				
APPLICATION		DO NOT SCALE DRAWING			



TITLE:		
SIZE	DWG. NO.	REV
A	TE-18008-01	
SCALE: 1:12	WEIGHT:	SHEET 1 OF 1

2

1

2

1

B

B

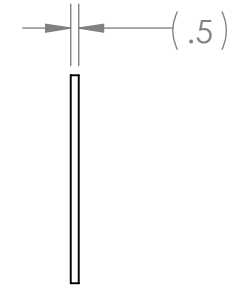
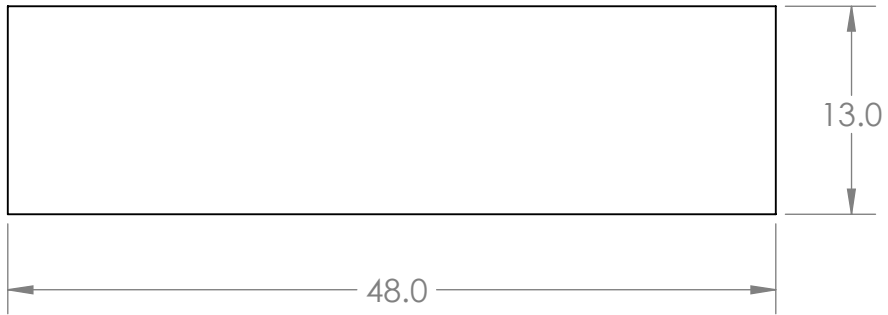

- Notes:
1. Material: 1/2" AC Plywood
 2. QTY. Needed: 4

A

A

PROPRIETARY AND CONFIDENTIAL
 THE INFORMATION CONTAINED IN THIS DRAWING IS THE SOLE PROPERTY OF **FIRST®**. Any REPRODUCTION IN PART OR AS A WHOLE WITHOUT THE WRITTEN PERMISSION OF **FIRST®** IS PROHIBITED.

		UNLESS OTHERWISE SPECIFIED:		NAME	DATE
		DIMENSIONS ARE IN INCHES	DRAWN		
		TOLERANCES:	CHECKED		
		FRACTIONAL ± 1/16	ENG APPR.		
		ANGULAR: MACH ± 1° BEND ± 1°	MFG APPR.		
		TWO PLACE DECIMAL ± .01	Q.A.		
		THREE PLACE DECIMAL ± .001	COMMENTS:		
		INTERPRET GEOMETRIC TOLERANCING PER:			
		MATERIAL			
		FINISH			
NEXT ASSY	USED ON				
APPLICATION		DO NOT SCALE DRAWING			



TITLE:		
SIZE	DWG. NO.	REV
A	TE-18008-02	
SCALE: 1:12	WEIGHT:	SHEET 1 OF 1

2

1

2

1

B

B

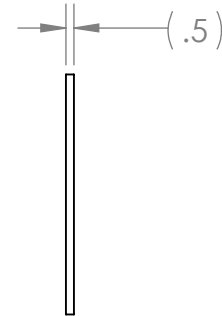
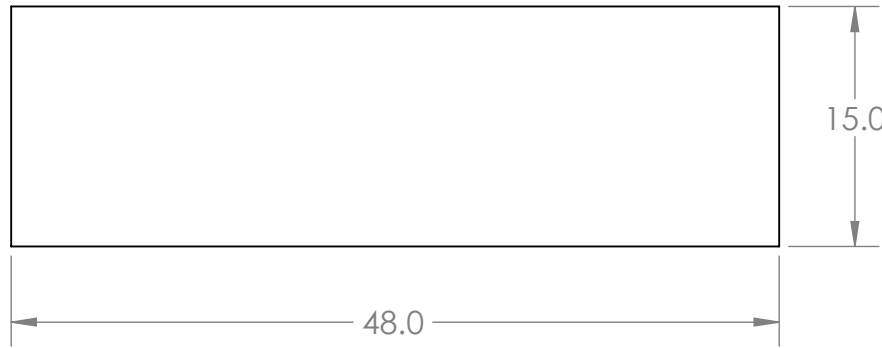

Notes:

- 1. Material: 1/2" AC Plywood
- 2. QTY. Needed: 2

A

A

PROPRIETARY AND CONFIDENTIAL
 THE INFORMATION CONTAINED IN THIS DRAWING IS THE SOLE PROPERTY OF **FIRST®**. Any REPRODUCTION IN PART OR AS A WHOLE WITHOUT THE WRITTEN PERMISSION OF **FIRST®** IS PROHIBITED.

		UNLESS OTHERWISE SPECIFIED:		NAME	DATE
		DIMENSIONS ARE IN INCHES	DRAWN		
		TOLERANCES:	CHECKED		
		FRACTIONAL ± 1/16	ENG APPR.		
		ANGULAR: MACH ± 1° BEND ± 1°	MFG APPR.		
		TWO PLACE DECIMAL ± .01	Q.A.		
		THREE PLACE DECIMAL ± .001	COMMENTS:		
		INTERPRET GEOMETRIC TOLERANCING PER:			
		MATERIAL			
		1/2" Ply			
		FINISH			
NEXT ASSY	USED ON				
	APPLICATION	DO NOT SCALE DRAWING			



TITLE:		
SIZE	DWG. NO.	REV
A	TE-18008-03	
SCALE: 1:12	WEIGHT:	SHEET 1 OF 1

2

1

2

1

B

B

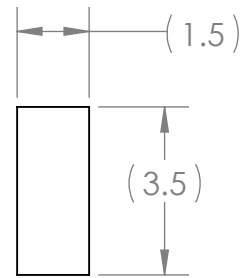
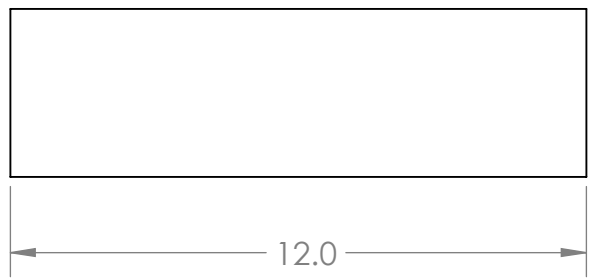

Notes:

- 1. Material: 2" x 4" Pine Lumber
- 2. QTY. Needed: 2

A

A

PROPRIETARY AND CONFIDENTIAL
 THE INFORMATION CONTAINED IN THIS DRAWING IS THE SOLE PROPERTY OF **FIRST®**. Any REPRODUCTION IN PART OR AS A WHOLE WITHOUT THE WRITTEN PERMISSION OF **FIRST®** IS PROHIBITED.

		UNLESS OTHERWISE SPECIFIED:		NAME	DATE
		DIMENSIONS ARE IN INCHES	DRAWN		
		TOLERANCES:	CHECKED		
		FRACTIONAL ± 1/16	ENG APPR.		
		ANGULAR: MACH ± 1° BEND ± 1°	MFG APPR.		
		TWO PLACE DECIMAL ± .01	Q.A.		
		THREE PLACE DECIMAL ± .001	COMMENTS:		
		INTERPRET GEOMETRIC TOLERANCING PER:			
		MATERIAL			
		2x4			
		FINISH			
NEXT ASSY	USED ON				
APPLICATION		DO NOT SCALE DRAWING			



TITLE:		
SIZE	DWG. NO.	REV
A	TE-18008-04	
SCALE: 1:4	WEIGHT:	SHEET 1 OF 1

2

1

2

1

B

B

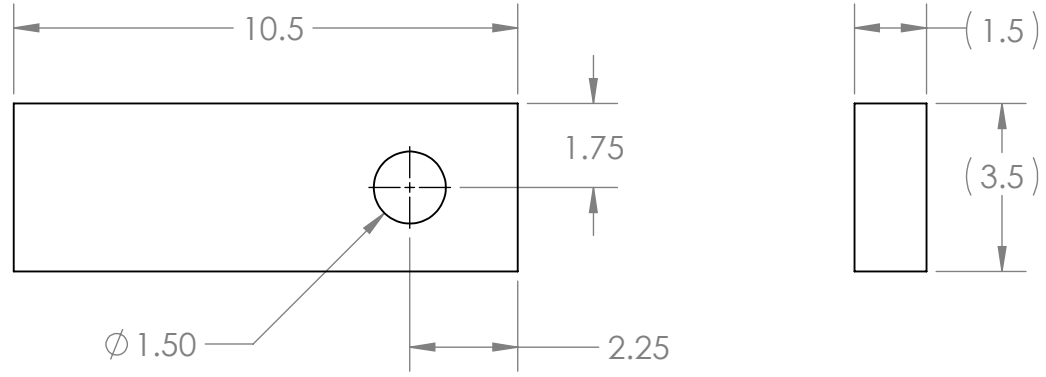

- Notes:
1. Material: 2" x 4" Pine Lumber
 2. QTY. Needed: 2

A

A

PROPRIETARY AND CONFIDENTIAL
 THE INFORMATION CONTAINED IN THIS DRAWING IS THE SOLE PROPERTY OF **FIRST®**. Any REPRODUCTION IN PART OR AS A WHOLE WITHOUT THE WRITTEN PERMISSION OF **FIRST®** IS PROHIBITED.

		UNLESS OTHERWISE SPECIFIED:		NAME	DATE
		DIMENSIONS ARE IN INCHES TOLERANCES: FRACTIONAL ± 1/16 ANGULAR: MACH ± 1° BEND ± 1° TWO PLACE DECIMAL ± .01 THREE PLACE DECIMAL ± .001	DRAWN		
		INTERPRET GEOMETRIC TOLERANCING PER:	CHECKED		
		MATERIAL 2x4	ENG APPR.		
NEXT ASSY	USED ON	FINISH	MFG APPR.		
		APPLICATION	Q.A.		
		DO NOT SCALE DRAWING	COMMENTS:		



TITLE:		
SIZE	DWG. NO.	REV
A	TE-18008-05	
SCALE: 1:4	WEIGHT:	SHEET 1 OF 1

2

1

2

1

B

B

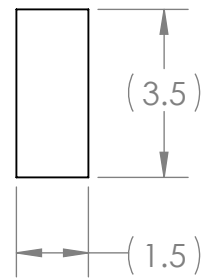
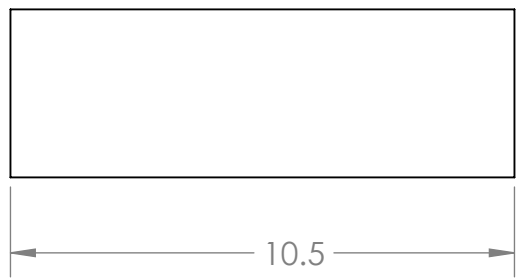

- Notes:
1. Material: 2" x 4" Pine Lumber
 2. QTY. Needed: 4

A

A

PROPRIETARY AND CONFIDENTIAL
 THE INFORMATION CONTAINED IN THIS DRAWING IS THE SOLE PROPERTY OF **FIRST®**. Any REPRODUCTION IN PART OR AS A WHOLE WITHOUT THE WRITTEN PERMISSION OF **FIRST®** IS PROHIBITED.

		UNLESS OTHERWISE SPECIFIED:		NAME	DATE
		DIMENSIONS ARE IN INCHES	DRAWN		
		TOLERANCES:	CHECKED		
		FRACTIONAL ± 1/16	ENG APPR.		
		ANGULAR: MACH ± 1° BEND ± 1°	MFG APPR.		
		TWO PLACE DECIMAL ± .01	Q.A.		
		THREE PLACE DECIMAL ± .001	COMMENTS:		
		INTERPRET GEOMETRIC TOLERANCING PER:			
		MATERIAL			
		2x4			
NEXT ASSY	USED ON	FINISH			
		DO NOT SCALE DRAWING			



TITLE:		
SIZE	DWG. NO.	REV
A	TE-18008-06	
SCALE: 1:4	WEIGHT:	SHEET 1 OF 1

2

1

2

1

B

B

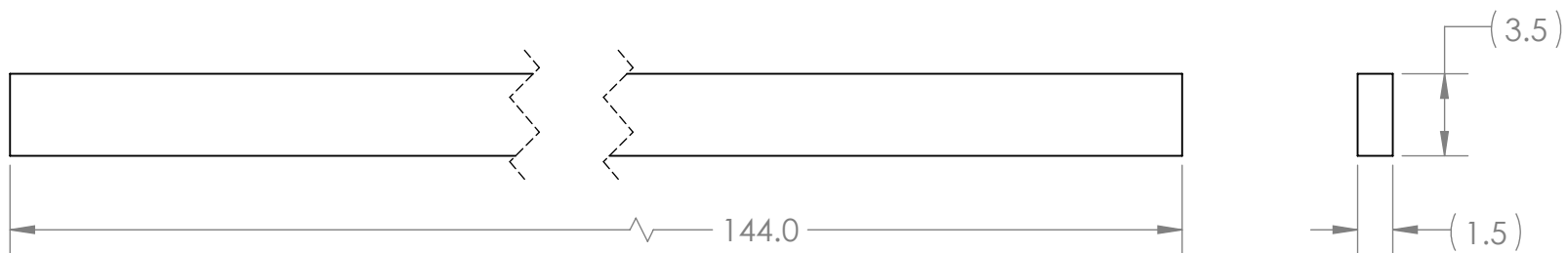



Notes:

1. Material: 2" x 4" Pine Lumber
2. QTY. Needed: 2

A

A

<p>PROPRIETARY AND CONFIDENTIAL THE INFORMATION CONTAINED IN THIS DRAWING IS THE SOLE PROPERTY OF FIRST®. Any REPRODUCTION IN PART OR AS A WHOLE WITHOUT THE WRITTEN PERMISSION OF FIRST® IS PROHIBITED.</p>			UNLESS OTHERWISE SPECIFIED:		NAME	DATE	 		
			DIMENSIONS ARE IN INCHES TOLERANCES: FRACTIONAL $\pm 1/16$ ANGULAR: MACH $\pm 1^\circ$ BEND $\pm 1^\circ$ TWO PLACE DECIMAL $\pm .01$ THREE PLACE DECIMAL $\pm .001$	DRAWN				TITLE:	
			INTERPRET GEOMETRIC TOLERANCING PER:	CHECKED					
			MATERIAL 2x4x12	ENG APPR.					
			FINISH	MFG APPR.					
	NEXT ASSY	USED ON		Q.A.			SIZE	DWG. NO.	REV
	APPLICATION		DO NOT SCALE DRAWING	COMMENTS:			A TE-18008-07		
							SCALE: 1:8	WEIGHT:	SHEET 1 OF 1

2

1

2

1

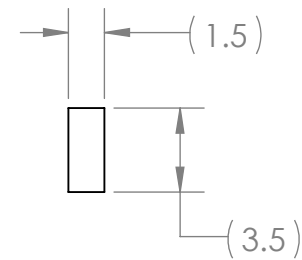
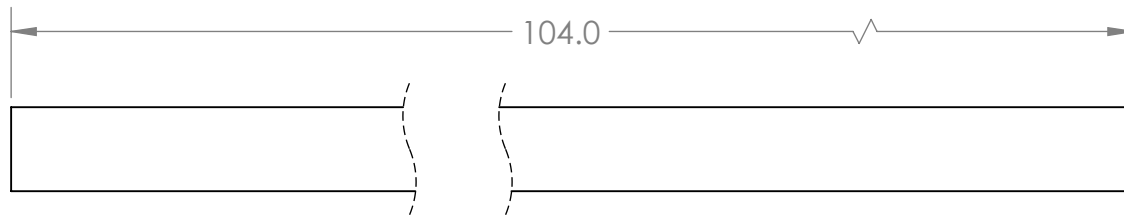

Notes:

- 1. Material: 2" x 4" Pine Lumber
- 2. QTY. Needed: 2

B

B

A

A

PROPRIETARY AND CONFIDENTIAL
 THE INFORMATION CONTAINED IN THIS DRAWING IS THE SOLE PROPERTY OF **FIRST®**. Any REPRODUCTION IN PART OR AS A WHOLE WITHOUT THE WRITTEN PERMISSION OF **FIRST®** IS PROHIBITED.

		UNLESS OTHERWISE SPECIFIED:		NAME	DATE
		DIMENSIONS ARE IN INCHES	DRAWN		
		TOLERANCES:	CHECKED		
		FRACTIONAL ± 1/16	ENG APPR.		
		ANGULAR: MACH ± 1° BEND ± 1°	MFG APPR.		
		TWO PLACE DECIMAL ± .01	Q.A.		
		THREE PLACE DECIMAL ± .001	COMMENTS:		
		INTERPRET GEOMETRIC TOLERANCING PER:			
		MATERIAL			
		2x4x12			
		FINISH			
NEXT ASSY	USED ON				
APPLICATION		DO NOT SCALE DRAWING			



TITLE:		
SIZE	DWG. NO.	REV
A	TE-18008-08	
SCALE: 1:8	WEIGHT:	SHEET 1 OF 1

2

1

2

1

B

B

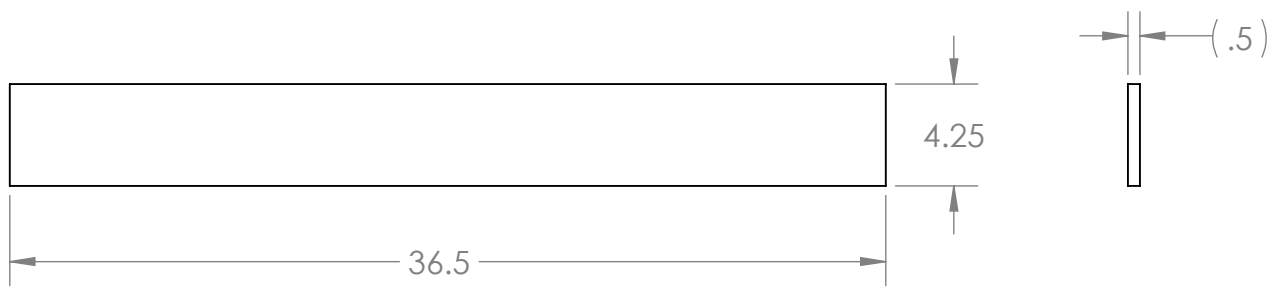

Notes:

- 1. Material: 1/2" AC Plywood
- 2. QTY. Needed: 4

A

A

PROPRIETARY AND CONFIDENTIAL
 THE INFORMATION CONTAINED IN THIS DRAWING IS THE SOLE PROPERTY OF **FIRST®**. Any REPRODUCTION IN PART OR AS A WHOLE WITHOUT THE WRITTEN PERMISSION OF **FIRST®** IS PROHIBITED.

		UNLESS OTHERWISE SPECIFIED:		NAME	DATE
		DIMENSIONS ARE IN INCHES	DRAWN		
		TOLERANCES:	CHECKED		
		FRACTIONAL ± 1/16	ENG APPR.		
		ANGULAR: MACH ± 1° BEND ± 1°	MFG APPR.		
		TWO PLACE DECIMAL ± .01	Q.A.		
		THREE PLACE DECIMAL ± .001	COMMENTS:		
		INTERPRET GEOMETRIC TOLERANCING PER:			
		MATERIAL			
		1/2" Ply			
		FINISH			
NEXT ASSY	USED ON				
		APPLICATION			
		DO NOT SCALE DRAWING			



TITLE:		
SIZE	DWG. NO.	REV
A	TE-18008-09	
SCALE: 1:8	WEIGHT:	SHEET 1 OF 1

2

1

2

1

B

B

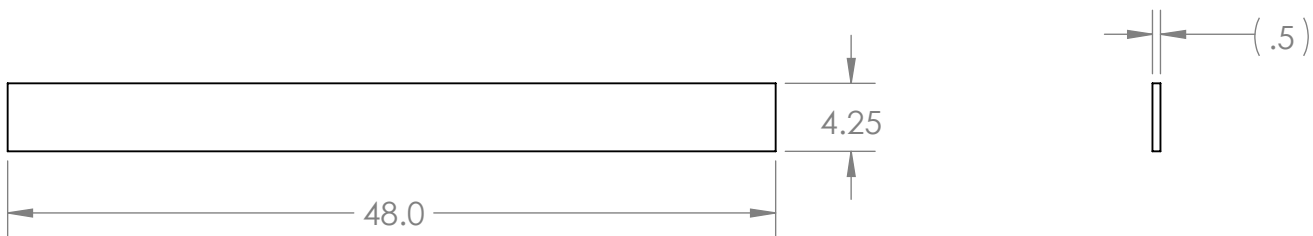



Notes:

- 1. Material: 1/2" AC Plywood
- 2. QTY. Needed: 2

A

A

<p>PROPRIETARY AND CONFIDENTIAL</p> <p>THE INFORMATION CONTAINED IN THIS DRAWING IS THE SOLE PROPERTY OF FIRST®. Any REPRODUCTION IN PART OR AS A WHOLE WITHOUT THE WRITTEN PERMISSION OF FIRST® IS PROHIBITED.</p>			UNLESS OTHERWISE SPECIFIED:		NAME	DATE	 		
			DIMENSIONS ARE IN INCHES	DRAWN				TITLE:	
			TOLERANCES:	CHECKED					
			FRACTIONAL ± 1/16	ENG APPR.					
			ANGULAR: MACH ± 1° BEND ± 1°	MFG APPR.					
		TWO PLACE DECIMAL ± .01	Q.A.						
		THREE PLACE DECIMAL ± .001	COMMENTS:						
		INTERPRET GEOMETRIC TOLERANCING PER:	MATERIAL				SIZE	DWG. NO.	REV
			1/2 Ply				A	TE-18008-10	
	NEXT ASSY	USED ON	FINISH				SCALE: 1:12	WEIGHT:	SHEET 1 OF 1
	APPLICATION		DO NOT SCALE DRAWING						

2

1

2

1

B

B

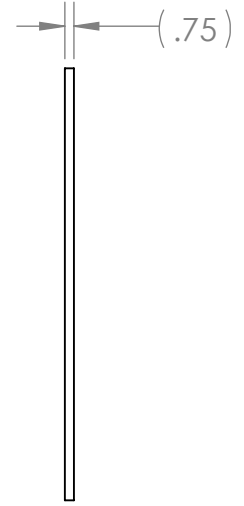
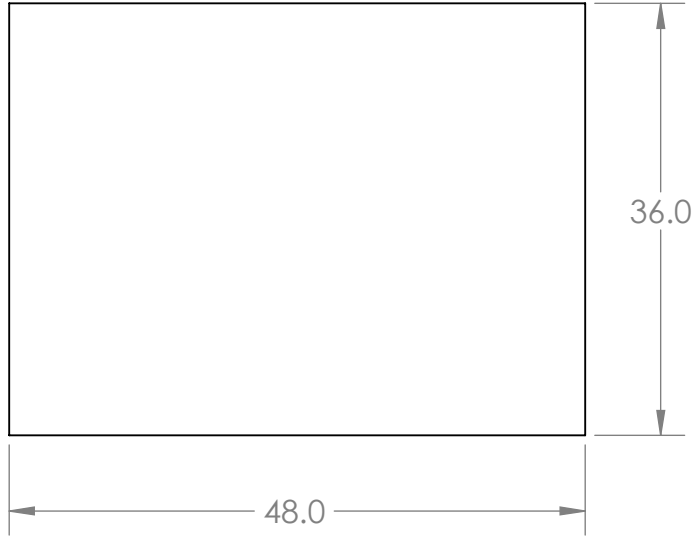

Notes:

- 1. Material: 3/4" AC Plywood
- 2. QTY. Needed: 2

A

A

PROPRIETARY AND CONFIDENTIAL
 THE INFORMATION CONTAINED IN THIS DRAWING IS THE SOLE PROPERTY OF **FIRST®**. Any REPRODUCTION IN PART OR AS A WHOLE WITHOUT THE WRITTEN PERMISSION OF **FIRST®** IS PROHIBITED.

		UNLESS OTHERWISE SPECIFIED:		NAME	DATE
		DIMENSIONS ARE IN INCHES	DRAWN		
		TOLERANCES:	CHECKED		
		FRACTIONAL ± 1/16	ENG APPR.		
		ANGULAR: MACH ± 1° BEND ± 1°	MFG APPR.		
		TWO PLACE DECIMAL ± .01	Q.A.		
		THREE PLACE DECIMAL ± .001	COMMENTS:		
		INTERPRET GEOMETRIC TOLERANCING PER:			
		MATERIAL			
		3/4" Ply			
		FINISH			
NEXT ASSY	USED ON				
APPLICATION		DO NOT SCALE DRAWING			



TITLE:		
SIZE	DWG. NO.	REV
A	TE-18008-11	
SCALE: 1:16	WEIGHT:	SHEET 1 OF 1

2

1

2

1

B

B

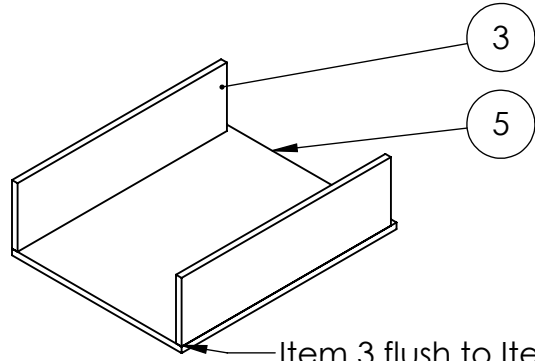

Item 3 flush to Item 5.
Secure with staples or screws.
Pre-drill in all steps to avoid splitting.

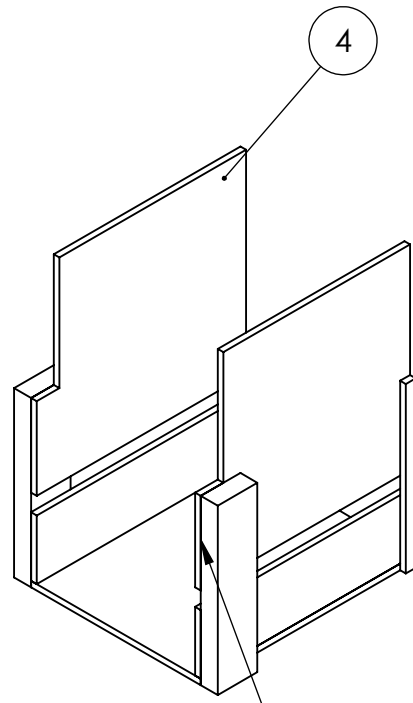

Item 4 flush to Item 6.
Secure with staples or screws.

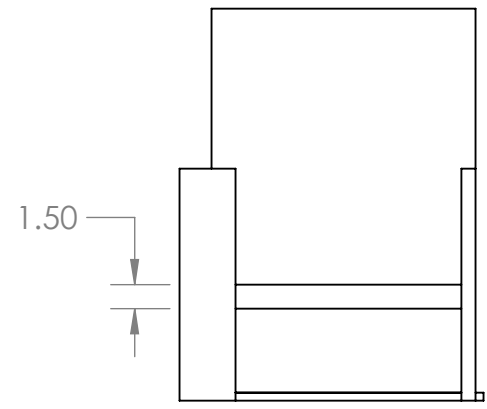

1.50

A

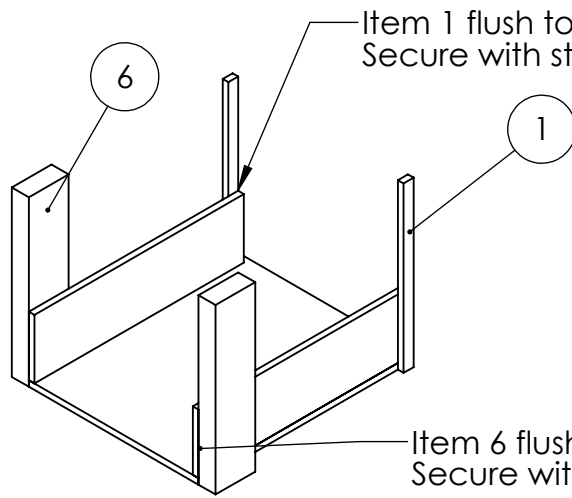

A



Item 1 flush to Item 3.
Secure with staples or screws.

Item 6 flush to Item 5.
Secure with staples or screws.

		UNLESS OTHERWISE SPECIFIED:		NAME	DATE
		DIMENSIONS ARE IN INCHES		DRAWN	
		TOLERANCES:		CHECKED	
		FRACTIONAL $\pm 1/16$		ENG APPR.	
		ANGULAR: MACH $\pm 1^\circ$ BEND $\pm 1^\circ$		MFG APPR.	
		TWO PLACE DECIMAL $\pm .01$		Q.A.	
		THREE PLACE DECIMAL $\pm .001$		COMMENTS:	
		INTERPRET GEOMETRIC TOLERANCING PER:			
		MATERIAL			
NEXT ASSY	USED ON	FINISH			
APPLICATION		DO NOT SCALE DRAWING			

TITLE:
Chute Assembly

SIZE	DWG. NO.	REV
A	TE-18009	

SCALE: 1:12 WEIGHT: SHEET 2 OF 3

PROPRIETARY AND CONFIDENTIAL
THE INFORMATION CONTAINED IN THIS DRAWING IS THE SOLE PROPERTY OF **FIRST®**. Any REPRODUCTION IN PART OR AS A WHOLE WITHOUT THE WRITTEN PERMISSION OF **FIRST®** IS PROHIBITED.

2

1

2

1

B

B

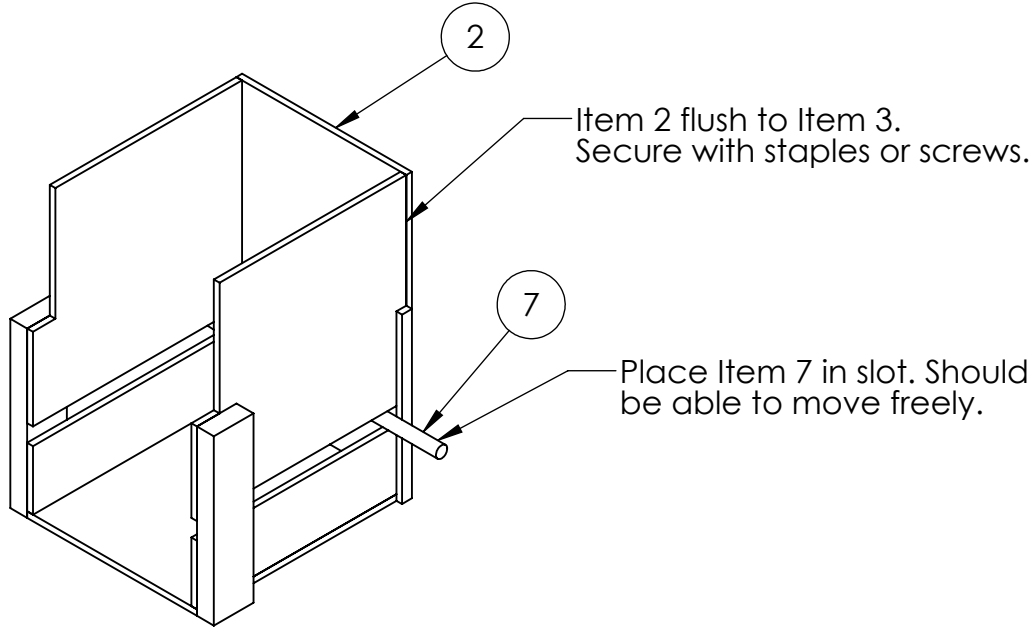

A

A

PROPRIETARY AND CONFIDENTIAL

THE INFORMATION CONTAINED IN THIS DRAWING IS THE SOLE PROPERTY OF **FIRST®**. Any REPRODUCTION IN PART OR AS A WHOLE WITHOUT THE WRITTEN PERMISSION OF **FIRST®** IS PROHIBITED.

		UNLESS OTHERWISE SPECIFIED:		NAME	DATE
		DIMENSIONS ARE IN INCHES	DRAWN		
		TOLERANCES:	CHECKED		
		FRACTIONAL ± 1/16	ENG APPR.		
		ANGULAR: MACH ± 1° BEND ± 1°	MFG APPR.		
		TWO PLACE DECIMAL ± .01	Q.A.		
		THREE PLACE DECIMAL ± .001	COMMENTS:		
		INTERPRET GEOMETRIC TOLERANCING PER:			
		MATERIAL			
		FINISH			
NEXT ASSY	USED ON				
APPLICATION		DO NOT SCALE DRAWING			



TITLE:
Chute Assembly

SIZE	DWG. NO.	REV
A	TE-18009	

SCALE: 1:12 WEIGHT: SHEET 3 OF 3

2

1

2

1

B

B

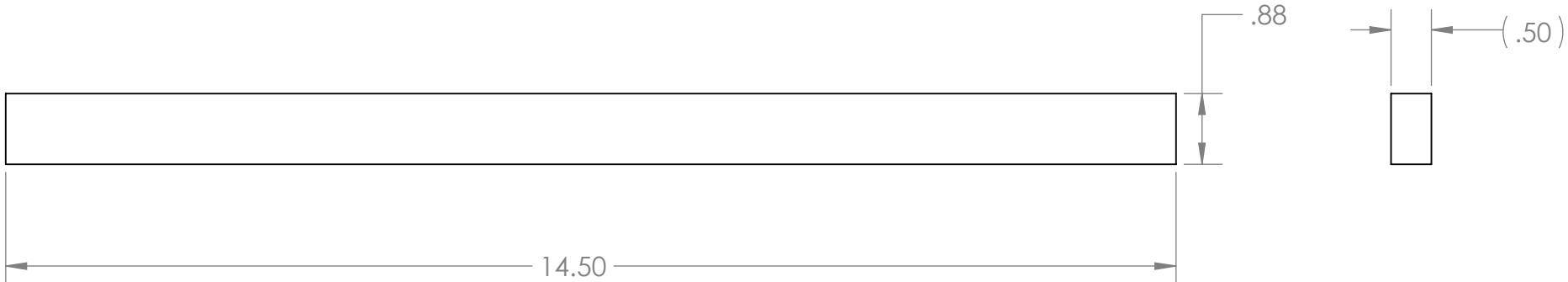

- Notes:
1. Material: 1/2" AC Plywood
 2. QTY. Needed: 4

A

A

PROPRIETARY AND CONFIDENTIAL
 THE INFORMATION CONTAINED IN THIS DRAWING IS THE SOLE PROPERTY OF **FIRST®**. Any REPRODUCTION IN PART OR AS A WHOLE WITHOUT THE WRITTEN PERMISSION OF **FIRST®** IS PROHIBITED.

		UNLESS OTHERWISE SPECIFIED:		NAME	DATE
		DIMENSIONS ARE IN INCHES	DRAWN		
		TOLERANCES:	CHECKED		
		FRACTIONAL ± 1/16	ENG APPR.		
		ANGULAR: MACH ± 1° BEND ± 1°	MFG APPR.		
		TWO PLACE DECIMAL ± .01	Q.A.		
		THREE PLACE DECIMAL ± .001	COMMENTS:		
		INTERPRET GEOMETRIC TOLERANCING PER:			
		MATERIAL			
		FINISH			
NEXT ASSY	USED ON				
APPLICATION		DO NOT SCALE DRAWING			



TITLE:		
SIZE	DWG. NO.	REV
A	TE-18009-1	
SCALE: 1:2	WEIGHT:	SHEET 1 OF 1

2

1

2

1

B

B

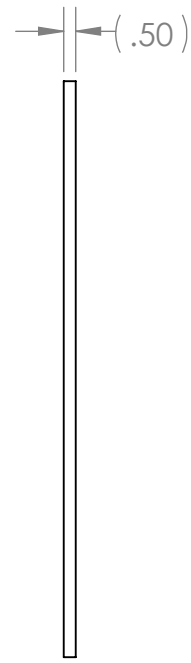
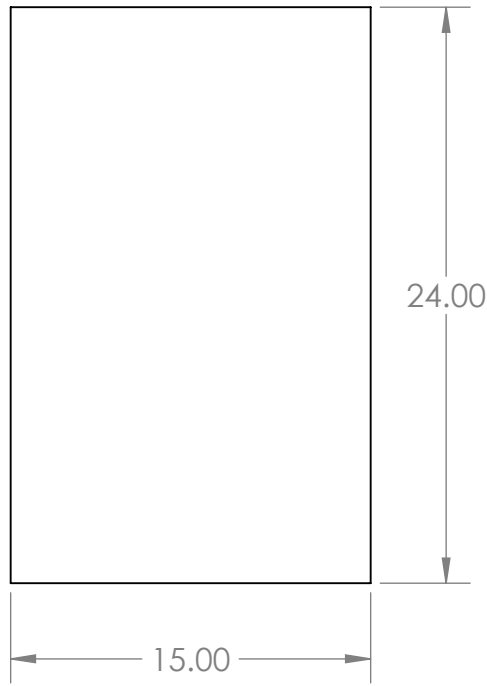

- Notes:
1. Material: 1/2" AC Plywood
 2. QTY. Needed: 2

A

A

PROPRIETARY AND CONFIDENTIAL
 THE INFORMATION CONTAINED IN THIS DRAWING IS THE SOLE PROPERTY OF **FIRST®**. Any REPRODUCTION IN PART OR AS A WHOLE WITHOUT THE WRITTEN PERMISSION OF **FIRST®** IS PROHIBITED.

		UNLESS OTHERWISE SPECIFIED:		NAME	DATE
		DIMENSIONS ARE IN INCHES	DRAWN		
		TOLERANCES:	CHECKED		
		FRACTIONAL ± 1/16	ENG APPR.		
		ANGULAR: MACH ± 1° BEND ± 1°	MFG APPR.		
		TWO PLACE DECIMAL ± .01	Q.A.		
		THREE PLACE DECIMAL ± .001	COMMENTS:		
		INTERPRET GEOMETRIC TOLERANCING PER:			
		MATERIAL			
NEXT ASSY	USED ON	FINISH			
APPLICATION		DO NOT SCALE DRAWING			



TITLE:		
SIZE	DWG. NO.	REV
A	TE-18009-2	
SCALE: 1:8	WEIGHT:	SHEET 1 OF 1

2

1

2

1

B

B

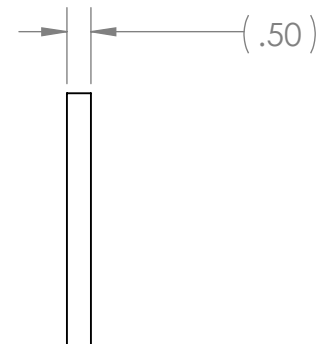

Notes:

1. Material: 1/2" AC Plywood
2. QTY. Needed: 4

A

A

PROPRIETARY AND CONFIDENTIAL
 THE INFORMATION CONTAINED IN THIS DRAWING IS THE SOLE PROPERTY OF **FIRST®**. Any REPRODUCTION IN PART OR AS A WHOLE WITHOUT THE WRITTEN PERMISSION OF **FIRST®** IS PROHIBITED.

		UNLESS OTHERWISE SPECIFIED:		NAME	DATE
		DIMENSIONS ARE IN INCHES	DRAWN		
		TOLERANCES:	CHECKED		
		FRACTIONAL ± 1/16	ENG APPR.		
		ANGULAR: MACH ± 1° BEND ± 1°	MFG APPR.		
		TWO PLACE DECIMAL ± .01	Q.A.		
		THREE PLACE DECIMAL ± .001	COMMENTS:		
		INTERPRET GEOMETRIC TOLERANCING PER:			
		MATERIAL			
NEXT ASSY	USED ON	FINISH			
APPLICATION		DO NOT SCALE DRAWING			



TITLE:		
SIZE	DWG. NO.	REV
A	TE-18009-3	
SCALE: 1:4	WEIGHT:	SHEET 1 OF 1

2

1

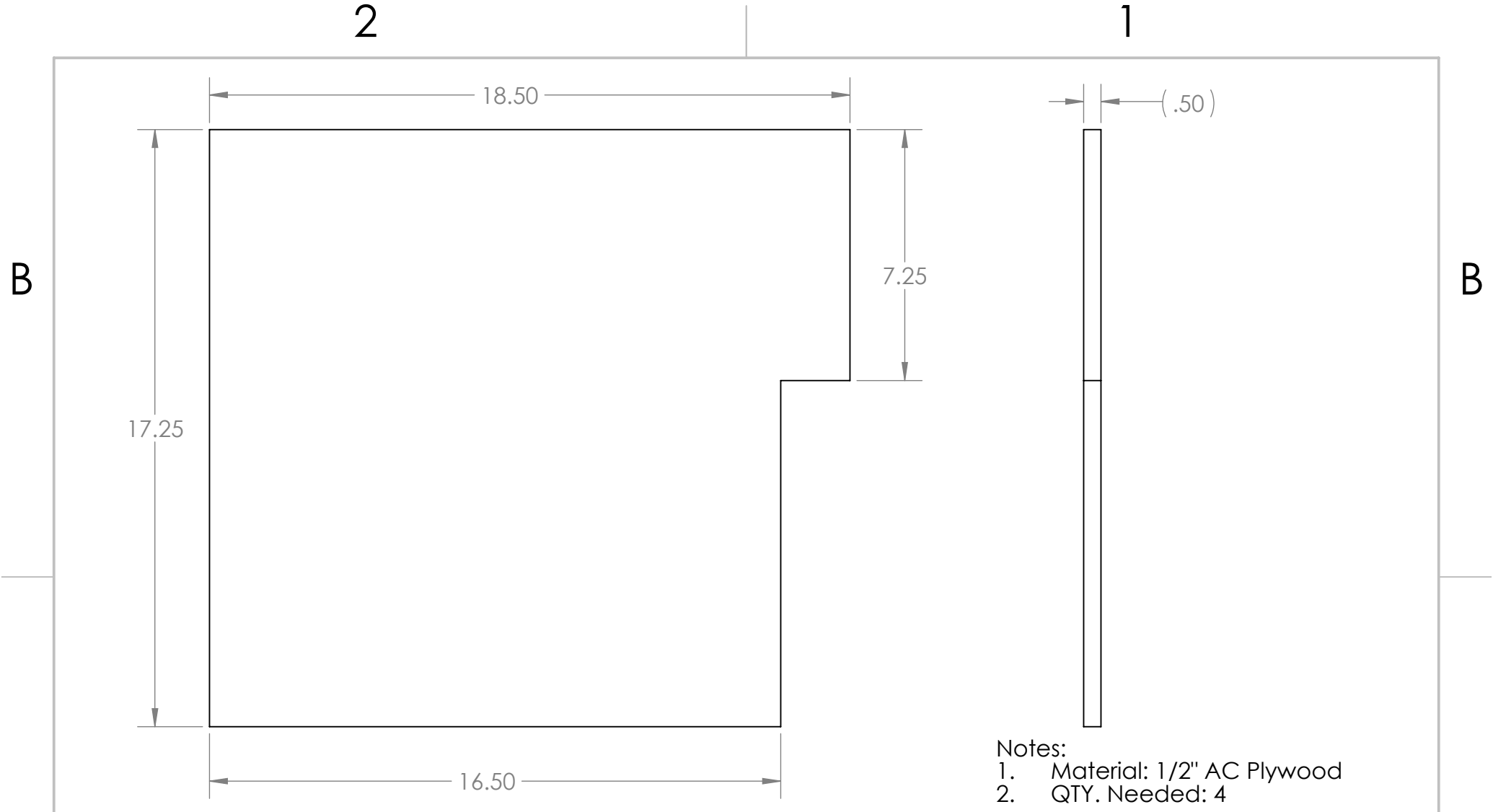

- Notes:
 1. Material: 1/2" AC Plywood
 2. QTY. Needed: 4

A

A

PROPRIETARY AND CONFIDENTIAL
 THE INFORMATION CONTAINED IN THIS DRAWING IS THE SOLE PROPERTY OF **FIRST®**. Any REPRODUCTION IN PART OR AS A WHOLE WITHOUT THE WRITTEN PERMISSION OF **FIRST®** IS PROHIBITED.

		UNLESS OTHERWISE SPECIFIED:		NAME	DATE
		DIMENSIONS ARE IN INCHES	DRAWN		
		TOLERANCES:	CHECKED		
		FRACTIONAL $\pm 1/16$	ENG APPR.		
		ANGULAR: MACH $\pm 1^\circ$ BEND $\pm 1^\circ$	MFG APPR.		
		TWO PLACE DECIMAL $\pm .01$	Q.A.		
		THREE PLACE DECIMAL $\pm .001$	COMMENTS:		
		INTERPRET GEOMETRIC TOLERANCING PER:			
		MATERIAL			
		.5 Ply			
NEXT ASSY	USED ON	FINISH			
	APPLICATION	DO NOT SCALE DRAWING			



TITLE:		
SIZE	DWG. NO.	REV
A	TE-18009-4	
SCALE: 1:4	WEIGHT:	SHEET 1 OF 1

2

1

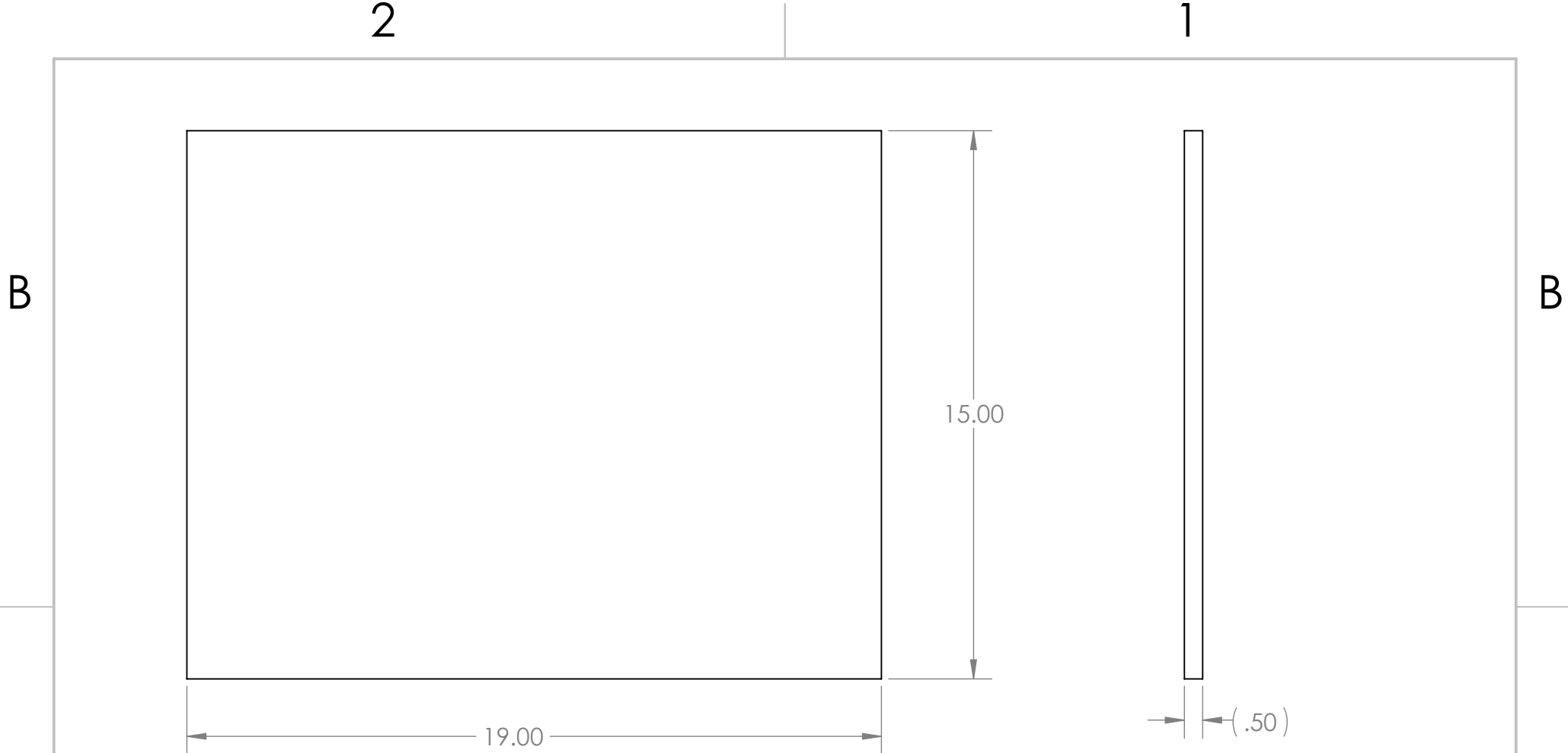



Notes:

1. Material: 1/2" AC Plywood
2. QTY. Needed: 2

PROPRIETARY AND CONFIDENTIAL
 THE INFORMATION CONTAINED IN THIS DRAWING IS THE SOLE PROPERTY OF **FIRST®**. Any REPRODUCTION IN PART OR AS A WHOLE WITHOUT THE WRITTEN PERMISSION OF **FIRST®** IS PROHIBITED.

		UNLESS OTHERWISE SPECIFIED:		NAME	DATE
		DIMENSIONS ARE IN INCHES	DRAWN		
		TOLERANCES:	CHECKED		
		FRACTIONAL ± 1/16	ENG APPR.		
		ANGULAR: MACH ± 1° BEND ± 1°	MFG APPR.		
		TWO PLACE DECIMAL ± .01	Q.A.		
		THREE PLACE DECIMAL ± .001	COMMENTS:		
		INTERPRET GEOMETRIC TOLERANCING PER:			
		MATERIAL			
NEXT ASSY	USED ON	FINISH			
APPLICATION		DO NOT SCALE DRAWING			

TITLE:

SIZE	DWG. NO.	REV
A	TE-18009-5	
SCALE: 1:4	WEIGHT:	SHEET 1 OF 1

A

A

2

1

2

1

B

B

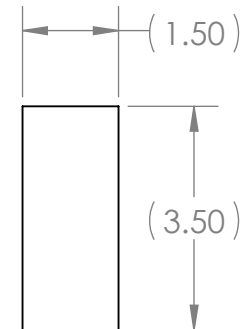
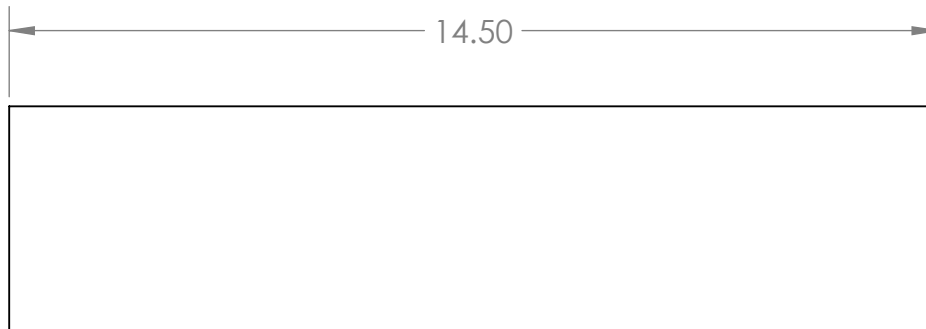

Notes:

- 1. Material: 2" x 4" Pine Lumber
- 2. QTY. Needed: 4

A

A

PROPRIETARY AND CONFIDENTIAL
 THE INFORMATION CONTAINED IN THIS DRAWING IS THE SOLE PROPERTY OF **FIRST®**. ANY REPRODUCTION IN PART OR AS A WHOLE WITHOUT THE WRITTEN PERMISSION OF **FIRST®** IS PROHIBITED.

		UNLESS OTHERWISE SPECIFIED:		NAME	DATE
		DIMENSIONS ARE IN INCHES	DRAWN		
		TOLERANCES:	CHECKED		
		FRACTIONAL ± 1/16	ENG APPR.		
		ANGULAR: MACH ± 1° BEND ± 1°	MFG APPR.		
		TWO PLACE DECIMAL ± .01	Q.A.		
		THREE PLACE DECIMAL ± .001	COMMENTS:		
		INTERPRET GEOMETRIC TOLERANCING PER:			
		MATERIAL			
	NEXT ASSY	FINISH			
	USED ON				
	APPLICATION	DO NOT SCALE DRAWING			



TITLE:		
SIZE	DWG. NO.	REV
A	TE-18009-6	
SCALE: 1:3	WEIGHT:	SHEET 1 OF 1

2

1

2

1

B

B

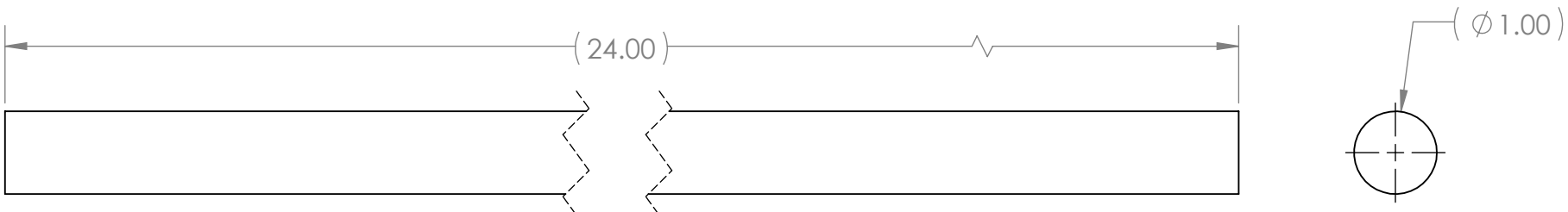

- Notes:
1. Material: 1" Dowel Rod
 2. QTY. Needed: 2

A

A

PROPRIETARY AND CONFIDENTIAL
 THE INFORMATION CONTAINED IN THIS DRAWING IS THE SOLE PROPERTY OF **FIRST®**. ANY REPRODUCTION IN PART OR AS A WHOLE WITHOUT THE WRITTEN PERMISSION OF **FIRST®** IS PROHIBITED.

		UNLESS OTHERWISE SPECIFIED:		NAME	DATE
		DIMENSIONS ARE IN INCHES	DRAWN		
		TOLERANCES:	CHECKED		
		FRACTIONAL $\pm 1/16$	ENG APPR.		
		ANGULAR: MACH $\pm 1^\circ$ BEND $\pm 1^\circ$	MFG APPR.		
		TWO PLACE DECIMAL $\pm .01$	Q.A.		
		THREE PLACE DECIMAL $\pm .001$	COMMENTS:		
		INTERPRET GEOMETRIC TOLERANCING PER:			
		MATERIAL			
		FINISH			
NEXT ASSY	USED ON				
APPLICATION		DO NOT SCALE DRAWING			





TITLE:		
SIZE	DWG. NO.	REV
A	TE-18009-7	
SCALE: 1:2	WEIGHT:	SHEET 1 OF 1

2

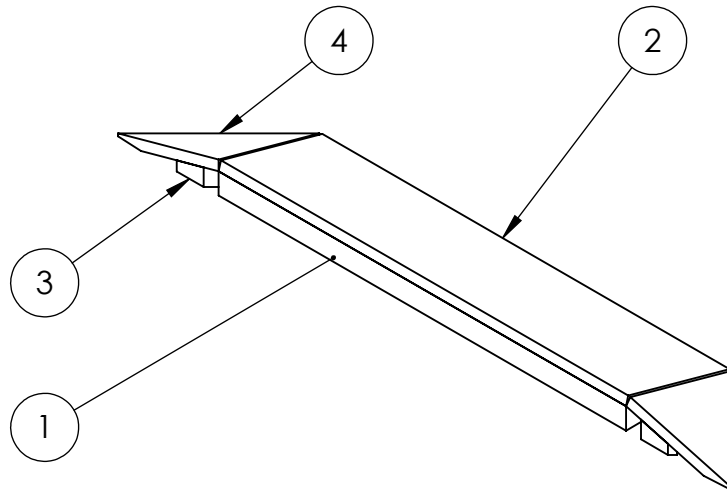
1



ITEM NO.	PART NUMBER	DESCRIPTION	QTY.
1	TE-18010-02		1
2	TE-18010-03		1
3	TE-18010-04		2
4	TE-18010-05		2

<p>PROPRIETARY AND CONFIDENTIAL</p> <p>THE INFORMATION CONTAINED IN THIS DRAWING IS THE SOLE PROPERTY OF FIRST®. Any REPRODUCTION IN PART OR AS A WHOLE WITHOUT THE WRITTEN PERMISSION OF FIRST® IS PROHIBITED.</p>			UNLESS OTHERWISE SPECIFIED:		NAME	DATE	  <p>TITLE:</p> <h1>Ramp, Exchange</h1> <p>SIZE DWG. NO. REV</p> <p>A TE-18010</p> <p>SCALE: 1:8 WEIGHT: SHEET 1 OF 3</p>
			DIMENSIONS ARE IN INCHES TOLERANCES: FRACTIONAL $\pm 1/16$ ANGULAR: MACH $\pm 1^\circ$ BEND $\pm 1^\circ$ TWO PLACE DECIMAL $\pm .01$ THREE PLACE DECIMAL $\pm .001$	DRAWN			
			INTERPRET GEOMETRIC TOLERANCING PER:	CHECKED			
			MATERIAL	ENG APPR.			
			FINISH	MFG APPR.			
	NEXT ASSY	USED ON	COMMENTS:				
	APPLICATION		DO NOT SCALE DRAWING				

B

B

A

A

2

1

2

1

2

1

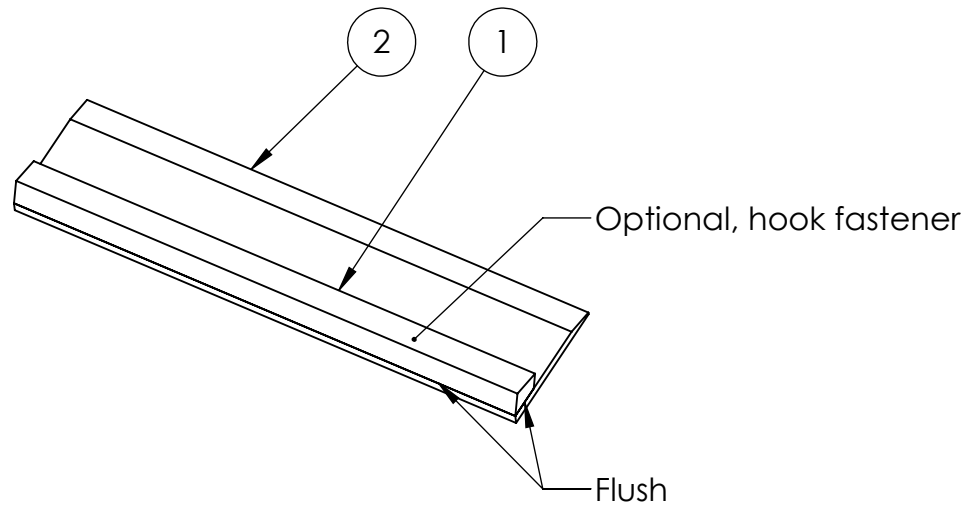

Align Item 1 and Item 2 as shown.
Fasten with wood screws.

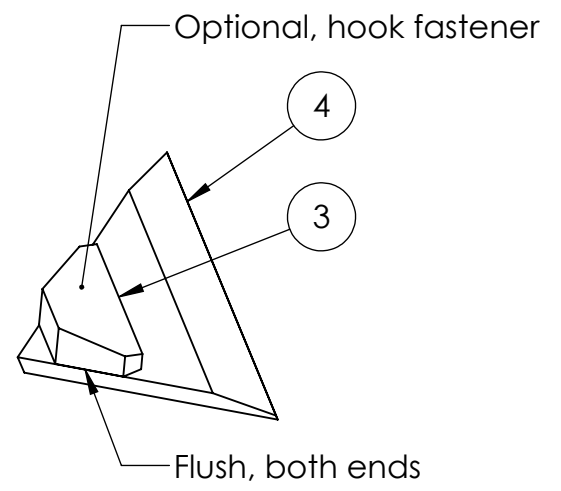

Align Item 3 and Item 4 as shown.
Fasten with wood screws. Build a qty. of two.

B



B

A

A

PROPRIETARY AND CONFIDENTIAL
THE INFORMATION CONTAINED IN THIS DRAWING IS THE SOLE PROPERTY OF **FIRST®**. Any REPRODUCTION IN PART OR AS A WHOLE WITHOUT THE WRITTEN PERMISSION OF **FIRST®**S PROHIBITED.

		UNLESS OTHERWISE SPECIFIED:		NAME	DATE
		DIMENSIONS ARE IN INCHES	DRAWN		
		TOLERANCES:	CHECKED		
		FRACTIONAL ± 1/16	ENG APPR.		
		ANGULAR: MACH ± 1° BEND ± 1°	MFG APPR.		
		TWO PLACE DECIMAL ± .01	Q.A.		
		THREE PLACE DECIMAL ± .001	COMMENTS:		
		INTERPRET GEOMETRIC TOLERANCING PER:			
		MATERIAL			
	NEXT ASSY	USED ON			
		FINISH			
		APPLICATION			
		DO NOT SCALE DRAWING			

TITLE:

Ramp, Exchange

SIZE	DWG. NO.	REV
A	TE-18010	
SCALE: 1:8	WEIGHT:	SHEET 2 OF 3

2

1

2

1

B

B

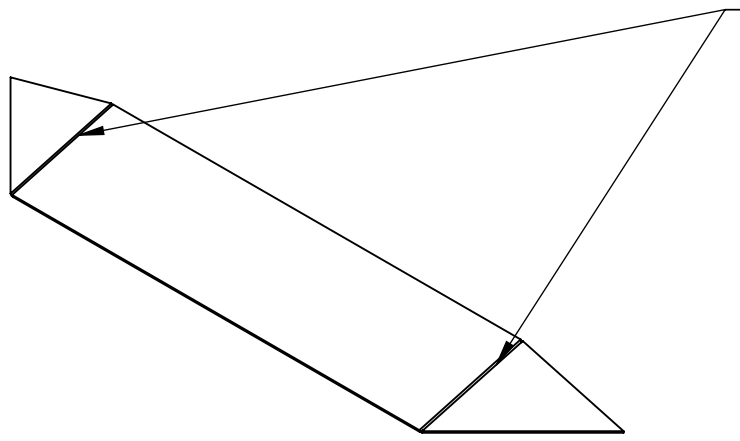

For Kickoff, assemble using tape at the seams, and to the floor.

A

A

PROPRIETARY AND CONFIDENTIAL
 THE INFORMATION CONTAINED IN THIS DRAWING IS THE SOLE PROPERTY OF <INSERT COMPANY NAME HERE>. ANY REPRODUCTION IN PART OR AS A WHOLE WITHOUT THE WRITTEN PERMISSION OF <INSERT COMPANY NAME HERE> IS PROHIBITED.

		UNLESS OTHERWISE SPECIFIED:		NAME	DATE
		DIMENSIONS ARE IN INCHES	DRAWN		
		TOLERANCES:	CHECKED		
		FRACTIONAL ±	ENG APPR.		
		ANGULAR: MACH ± BEND ±	MFG APPR.		
		TWO PLACE DECIMAL ±	Q.A.		
		THREE PLACE DECIMAL ±	COMMENTS:		
		INTERPRET GEOMETRIC TOLERANCING PER:			
		MATERIAL			
NEXT ASSY	USED ON	FINISH			
APPLICATION		DO NOT SCALE DRAWING			



TITLE:		
<h1>Ramp, Exchange</h1>		
SIZE	DWG. NO.	REV
A	TE-18010	
SCALE: 1:8	WEIGHT:	SHEET 3 OF 3

2

1

2

1

B

B

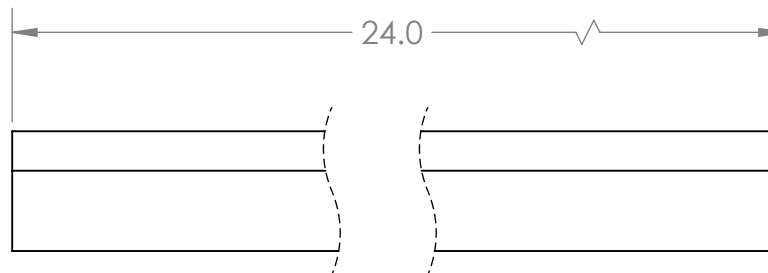
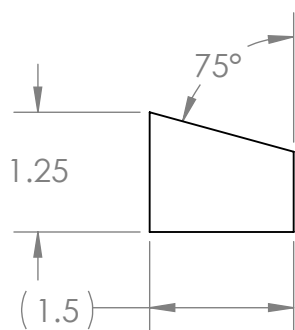



Notes:

1. Material: 2" x 4" Pine Lumber
2. QTY. Needed: 1

A

A

<p>PROPRIETARY AND CONFIDENTIAL</p> <p>THE INFORMATION CONTAINED IN THIS DRAWING IS THE SOLE PROPERTY OF FIRST®. Any REPRODUCTION IN PART OR AS A WHOLE WITHOUT THE WRITTEN PERMISSION OF FIRST® IS PROHIBITED.</p>			UNLESS OTHERWISE SPECIFIED:		NAME	DATE	 		
			DIMENSIONS ARE IN INCHES	DRAWN				TITLE:	
			TOLERANCES:	CHECKED					
			FRACTIONAL $\pm 1/16$	ENG APPR.					
			ANGULAR: MACH $\pm 1^\circ$ BEND $\pm 1^\circ$	MFG APPR.					
		TWO PLACE DECIMAL $\pm .01$	Q.A.						
		THREE PLACE DECIMAL $\pm .001$	COMMENTS:						
		INTERPRET GEOMETRIC TOLERANCING PER:	MATERIAL				SIZE	DWG. NO.	REV
	NEXT ASSY	USED ON	FINISH				A	TE-18010-02	
	APPLICATION		DO NOT SCALE DRAWING				SCALE: 1:2	WEIGHT:	SHEET 1 OF 1

2

1

2

1

B

B

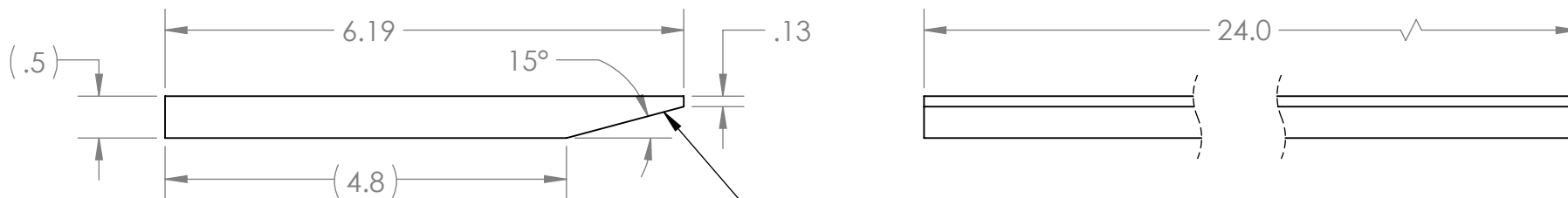



Please exercise caution when cutting chamfer. If you feel the cut is too dangerous, cut a simplified 4.75" x 24" piece of plywood. Both versions will be able to represent the assembly, but the chamfered will be closer to the real design.

Notes:

1. Material: 1/2" AC Plywood
2. QTY. Needed: 1

A

A

		UNLESS OTHERWISE SPECIFIED:		NAME	DATE	 	
		DIMENSIONS ARE IN INCHES TOLERANCES: FRACTIONAL ± 1/16 ANGULAR: MACH ± 1° BEND ± 1° TWO PLACE DECIMAL ± .01 THREE PLACE DECIMAL ± .001		DRAWN			TITLE:
		INTERPRET GEOMETRIC TOLERANCING PER:		CHECKED			
		MATERIAL		ENG APPR.			
		FINISH		MFG APPR.			
		APPLICATION		COMMENTS:		Q.A.	
		DO NOT SCALE DRAWING					
						SIZE	
						DWG. NO.	
						REV	
						A	
						TE-18010-03	
						SCALE: 1:2	
						WEIGHT:	
						SHEET 1 OF 1	

PROPRIETARY AND CONFIDENTIAL

THE INFORMATION CONTAINED IN THIS DRAWING IS THE SOLE PROPERTY OF **FIRST®**. Any REPRODUCTION IN PART OR AS A WHOLE WITHOUT THE WRITTEN PERMISSION OF **FIRST®** IS PROHIBITED.

2

1

2

1

B

B

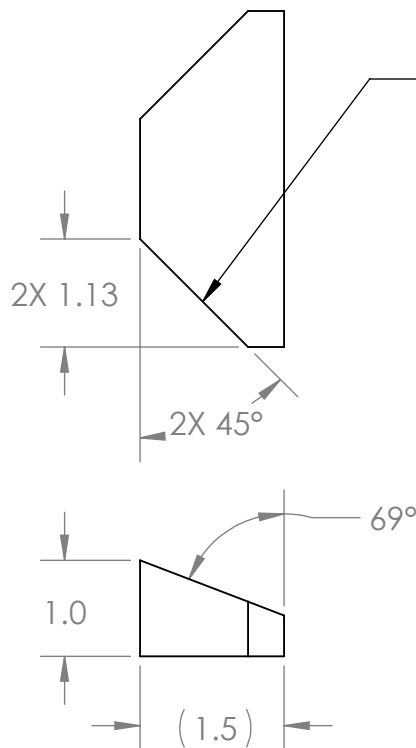

Please use caution when making chamfers. If you are unable to make this part, it may be omitted. It's a nice-to-have, not mandatory.

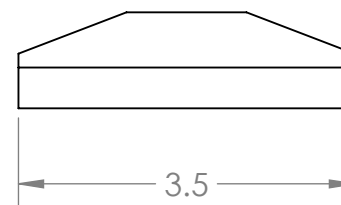
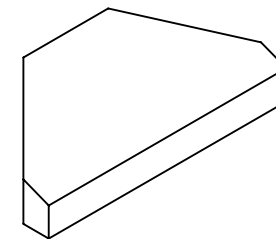



Notes:

1. Material: 2" x 4" Pine Lumber
2. QTY. Needed: 2

A

A

		UNLESS OTHERWISE SPECIFIED:			NAME	DATE	 	
		DIMENSIONS ARE IN INCHES		DRAWN			TITLE:	
		TOLERANCES:		CHECKED				
		FRACTIONAL ± 1/16		ENG APPR.				
		ANGULAR: MACH ± 1° BEND ± 1°		MFG APPR.				
		TWO PLACE DECIMAL ± .01		Q.A.			SIZE DWG. NO. REV	
		THREE PLACE DECIMAL ± .001		COMMENTS:			A TE-18010-04	
		INTERPRET GEOMETRIC TOLERANCING PER:					SCALE: 1:2 WEIGHT: SHEET 1 OF 1	
		MATERIAL						
		FINISH						
NEXT ASSY		USED ON						
APPLICATION		DO NOT SCALE DRAWING						

PROPRIETARY AND CONFIDENTIAL

THE INFORMATION CONTAINED IN THIS DRAWING IS THE SOLE PROPERTY OF **FIRST®**. Any REPRODUCTION IN PART OR AS A WHOLE WITHOUT THE WRITTEN PERMISSION OF **FIRST®** IS PROHIBITED.

2

1

B

B

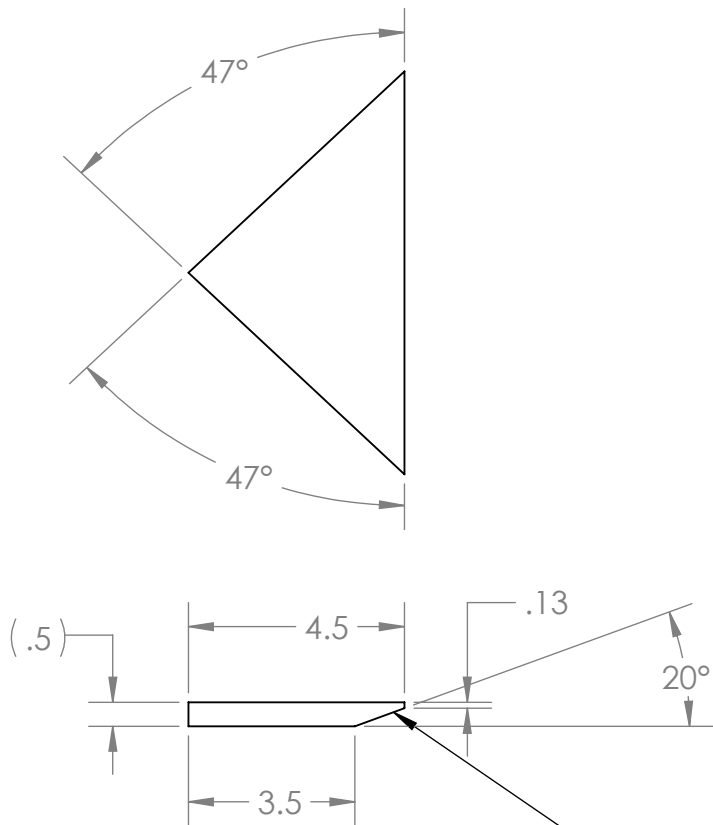



Notes:

1. Material; 1/2" AC Plywood
2. QTY. Needed: 2

Please exercise caution when cutting chamfer. Please note, if you feel you are unable to make this part, it can be omitted.

A

A

PROPRIETARY AND CONFIDENTIAL			UNLESS OTHERWISE SPECIFIED:		NAME	DATE	 	
			DIMENSIONS ARE IN INCHES	DRAWN				TITLE:
			TOLERANCES:	CHECKED				
			FRACTIONAL $\pm 1/16$	ENG APPR.				
			ANGULAR: MACH $\pm 1^\circ$ BEND $\pm 1^\circ$	MFG APPR.				
		TWO PLACE DECIMAL $\pm .01$	Q.A.				SIZE DWG. NO. REV A TE-18010-05	
		THREE PLACE DECIMAL $\pm .001$	COMMENTS:					
		INTERPRET GEOMETRIC TOLERANCING PER:						
		MATERIAL						
		FINISH						
		NEXT ASSY	USED ON					
		APPLICATION	DO NOT SCALE DRAWING					

2

1

SCALE: 1:4

WEIGHT:

SHEET 1 OF 1

4

3

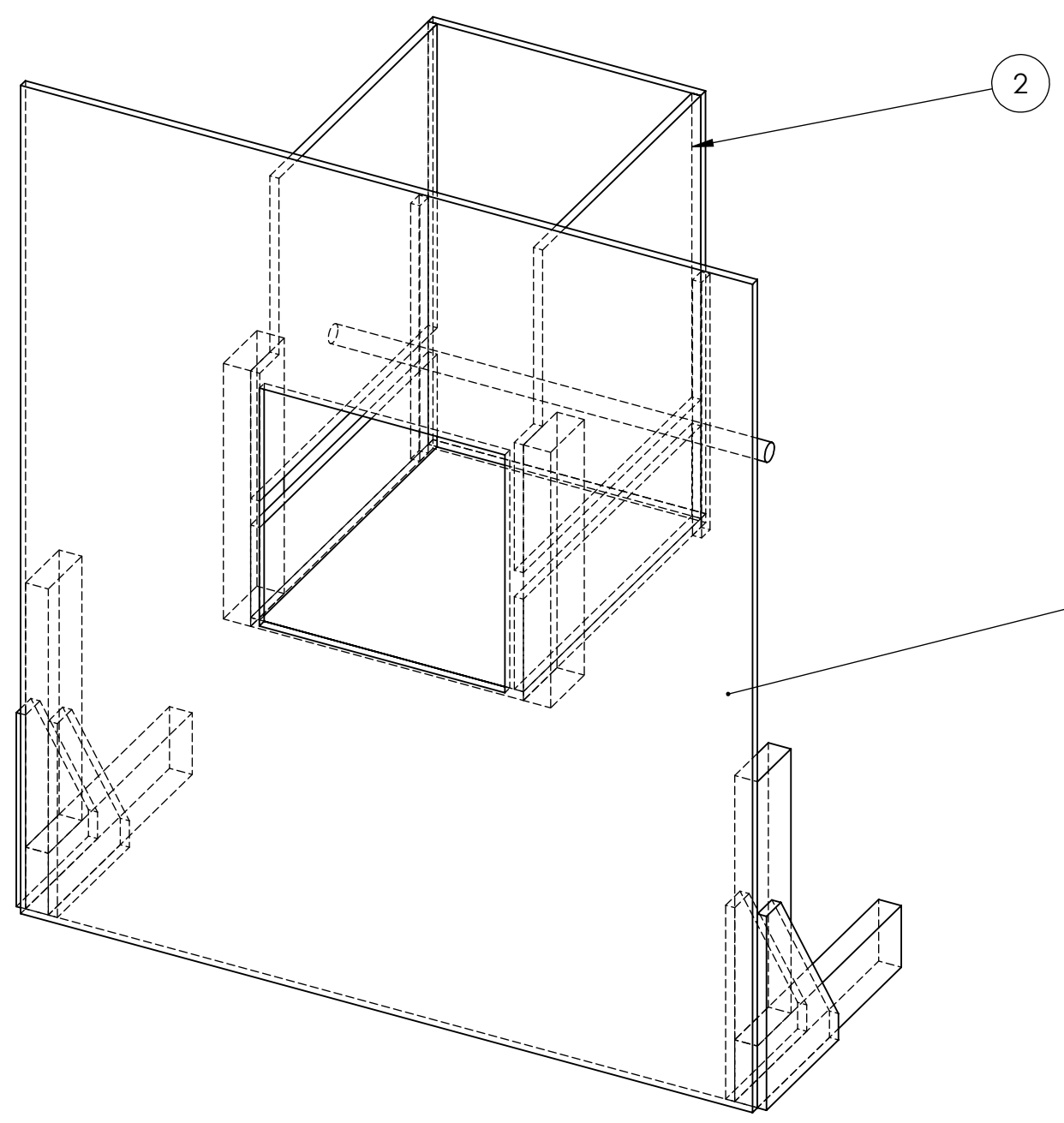

2

1



ITEM NO.	PART NUMBER	DESCRIPTION	QTY.
1	TE-18002	Portal	1
2	TE-18009	Chute Assembly	1

PROPRIETARY AND CONFIDENTIAL
 THE INFORMATION CONTAINED IN THIS DRAWING IS THE SOLE PROPERTY OF **FIRST®**. ANY REPRODUCTION IN PART OR AS A WHOLE WITHOUT THE WRITTEN PERMISSION OF **FIRST®** IS PROHIBITED.

UNLESS OTHERWISE SPECIFIED:		NAME	DATE	 
DIMENSIONS ARE IN INCHES TOLERANCES: FRACTIONAL ±1/16 ANGULAR: MACH ±1° BEND ±1° TWO PLACE DECIMAL ±.01 THREE PLACE DECIMAL ±.001		DRAWN		
INTERPRET GEOMETRIC TOLERANCING PER:		CHECKED		TITLE: <h2 style="text-align: center;">Portal Full Assembly</h2>
MATERIAL		ENG APPR.		
FINISH		MFG APPR.		
NEXT ASSY	USED ON	Q.A.		SIZE B DWG. NO. TE-18011 REV
APPLICATION		COMMENTS:		SCALE: 1:8 WEIGHT: SHEET 1 OF 2
DO NOT SCALE DRAWING				

4

3

2

1

A

A

B

B

4

3

2

1

1

2

B

B

A

A

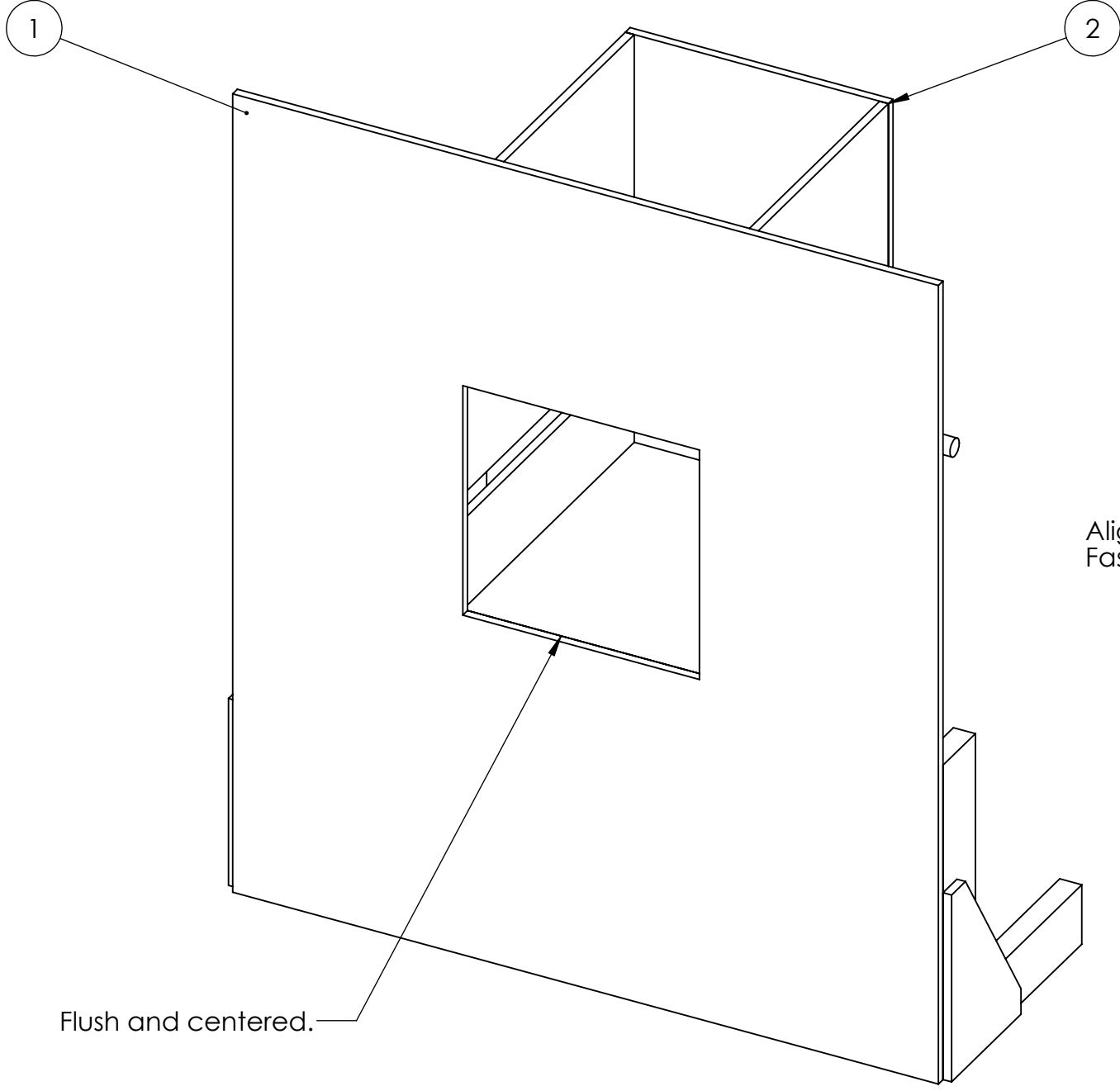

Align Item 2 as shown.
Fasten using wood screws.

Flush and centered.

PROPRIETARY AND CONFIDENTIAL
THE INFORMATION CONTAINED IN THIS DRAWING IS THE SOLE PROPERTY OF **FIRST®**. ANY REPRODUCTION IN PART OR AS A WHOLE WITHOUT THE WRITTEN PERMISSION OF **FIRST®** IS PROHIBITED.

		UNLESS OTHERWISE SPECIFIED:		NAME	DATE
		DIMENSIONS ARE IN INCHES	DRAWN		
		TOLERANCES:	CHECKED		
		FRACTIONAL: ±1/16	ENG APPR.		
		ANGULAR: MACH ±1° BEND ±1°	MFG APPR.		
		TWO PLACE DECIMAL ±.01	Q.A.		
		THREE PLACE DECIMAL ±.001	COMMENTS:		
		INTERPRET GEOMETRIC TOLERANCING PER:			
		MATERIAL			
		FINISH			
NEXT ASSY	USED ON				
APPLICATION		DO NOT SCALE DRAWING			



TITLE:		
Portal Full Assembly		
SIZE	DWG. NO.	REV
B	TE-18011	
SCALE: 1:8	WEIGHT:	SHEET 2 OF 2

4

3

2

1

4

3

2

1

B

B

A

A

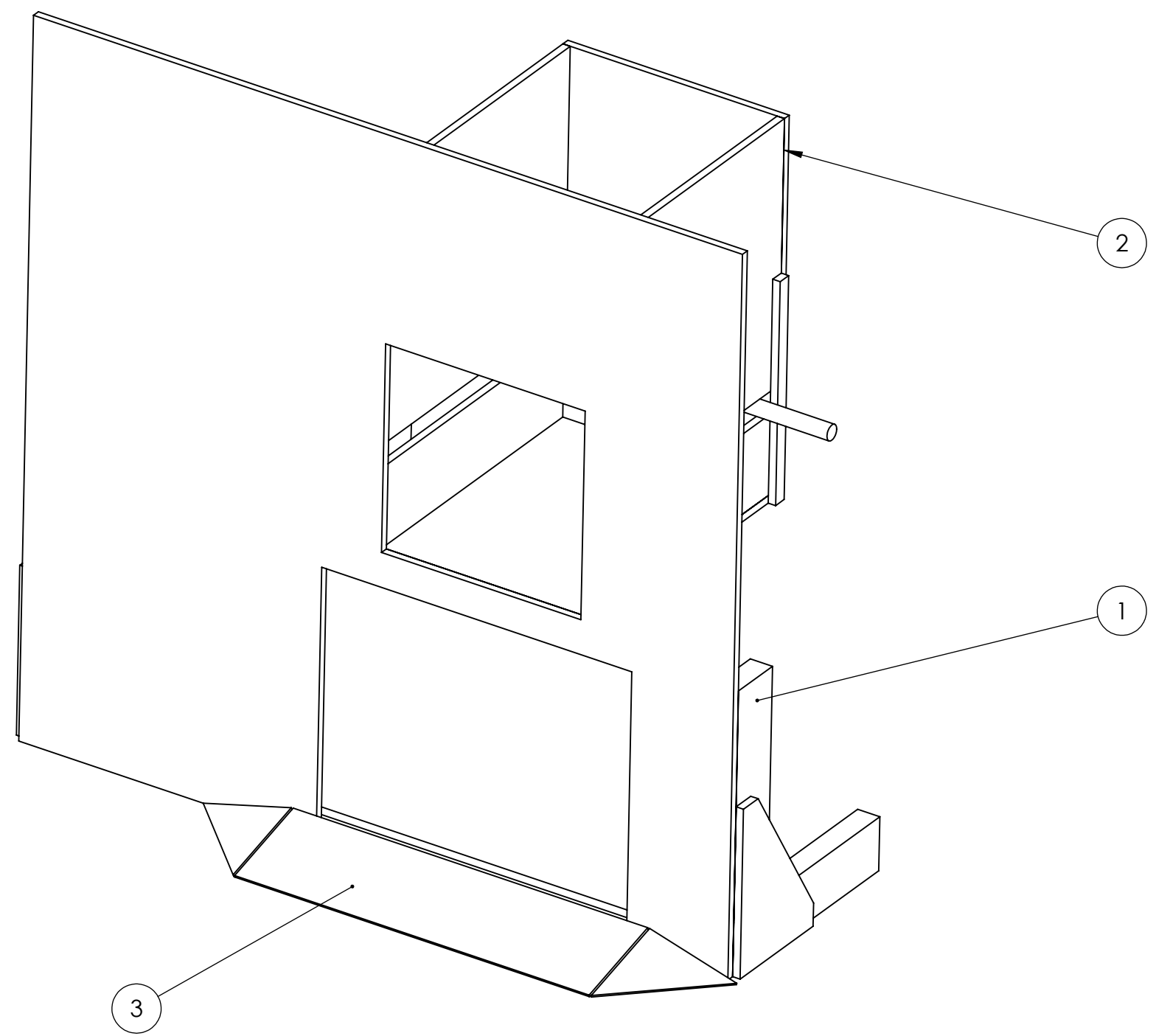

ITEM NO.	PART NUMBER	DESCRIPTION	QTY.
1	TE-18001	Exchange	1
2	TE-18009	Chute Assembly	1
3	TE-18010	Ramp, Exchange	1

PROPRIETARY AND CONFIDENTIAL
 THE INFORMATION CONTAINED IN THIS DRAWING IS THE SOLE PROPERTY OF **FIRST®**. ANY REPRODUCTION IN PART OR AS A WHOLE WITHOUT THE WRITTEN PERMISSION OF **FIRST®** IS PROHIBITED.

		UNLESS OTHERWISE SPECIFIED:	NAME	DATE
		DIMENSIONS ARE IN INCHES	DRAWN	
		TOLERANCES:	CHECKED	
		FRACTIONAL ±1/16	ENG APPR.	
		ANGULAR: MACH ±1° BEND ±1°	MFG APPR.	
		TWO PLACE DECIMAL ±.01	Q.A.	
		THREE PLACE DECIMAL ±.001	COMMENTS:	
		INTERPRET GEOMETRIC TOLERANCING PER:		
		MATERIAL		
NEXT ASSY	USED ON	FINISH		
APPLICATION		DO NOT SCALE DRAWING		



TITLE:
Exchange Full Assembly

SIZE DWG. NO. REV
B TE-18012

SCALE: 1:8 WEIGHT: SHEET 1 OF 2

4

3

2

1

4

3

2

1

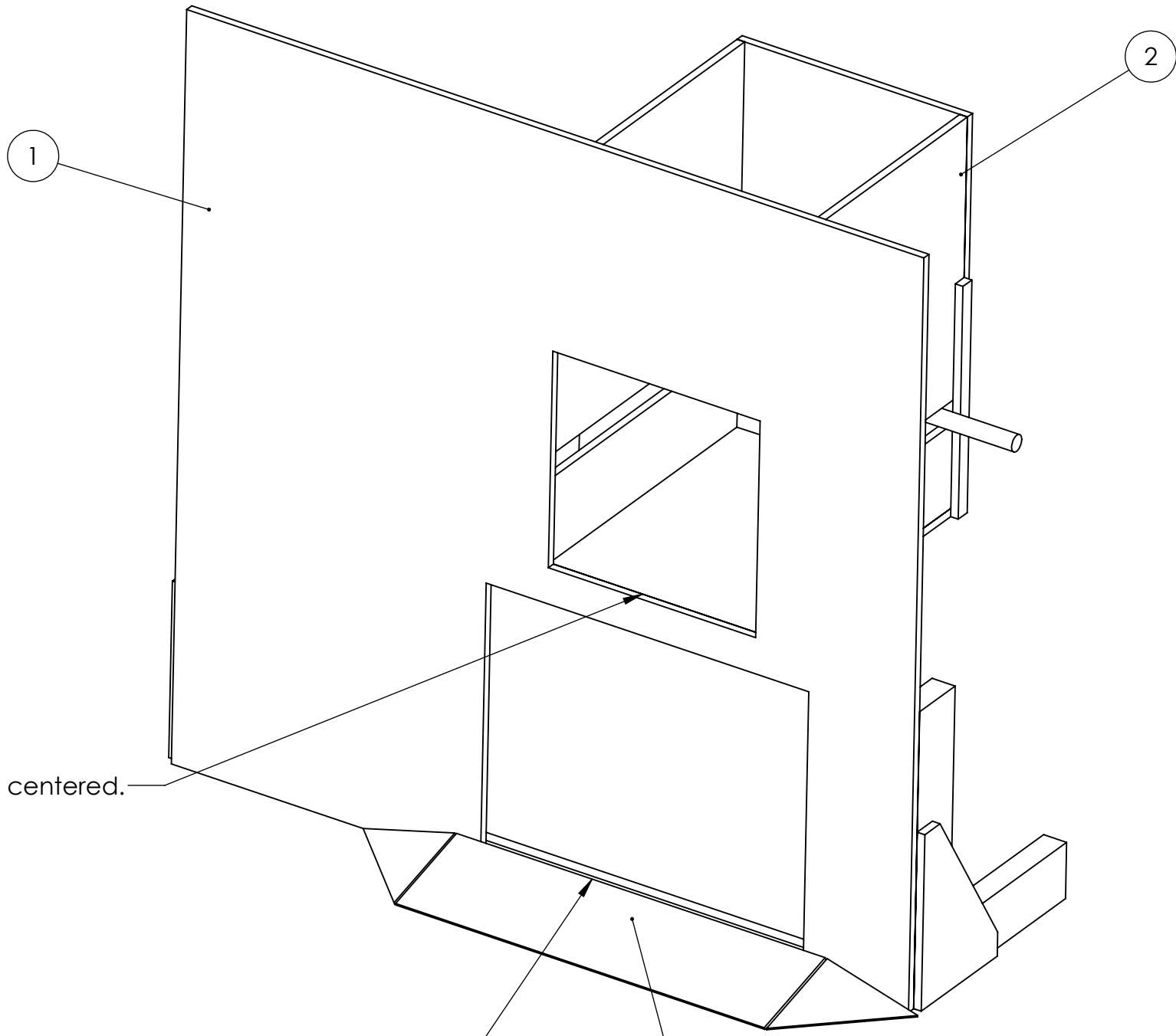

Step 1: Align Item 2 so it is flush and centered with the top opening. Fasten using wood screws.



Step 2: Align Item 3 so it is flush and centered with the bottom opening. Affix to floor using tape or hook and loop.

Flush and centered.

Flush and centered.

PROPRIETARY AND CONFIDENTIAL
 THE INFORMATION CONTAINED IN THIS DRAWING IS THE SOLE PROPERTY OF **FIRST®**. ANY REPRODUCTION IN PART OR AS A WHOLE WITHOUT THE WRITTEN PERMISSION OF **FIRST®** IS PROHIBITED.

		UNLESS OTHERWISE SPECIFIED:		NAME	DATE
		DIMENSIONS ARE IN INCHES TOLERANCES: FRACTIONAL ±1/16 ANGULAR: MACH ±1° BEND ±1° TWO PLACE DECIMAL ±.01 THREE PLACE DECIMAL ±.001		DRAWN	
		INTERPRET GEOMETRIC TOLERANCING PER:		CHECKED	
		MATERIAL		ENG APPR.	
		FINISH		MFG APPR.	
NEXT ASSY	USED ON			Q.A.	
APPLICATION		DO NOT SCALE DRAWING		COMMENTS:	

 		
TITLE:		
<h1>Exchange Full Assembly</h1>		
SIZE	DWG. NO.	REV
B	TE-18012	
SCALE: 1:8	WEIGHT:	SHEET 2 OF 2

4

3

2

1

B

B

A

A

4

3

2

1

B

B

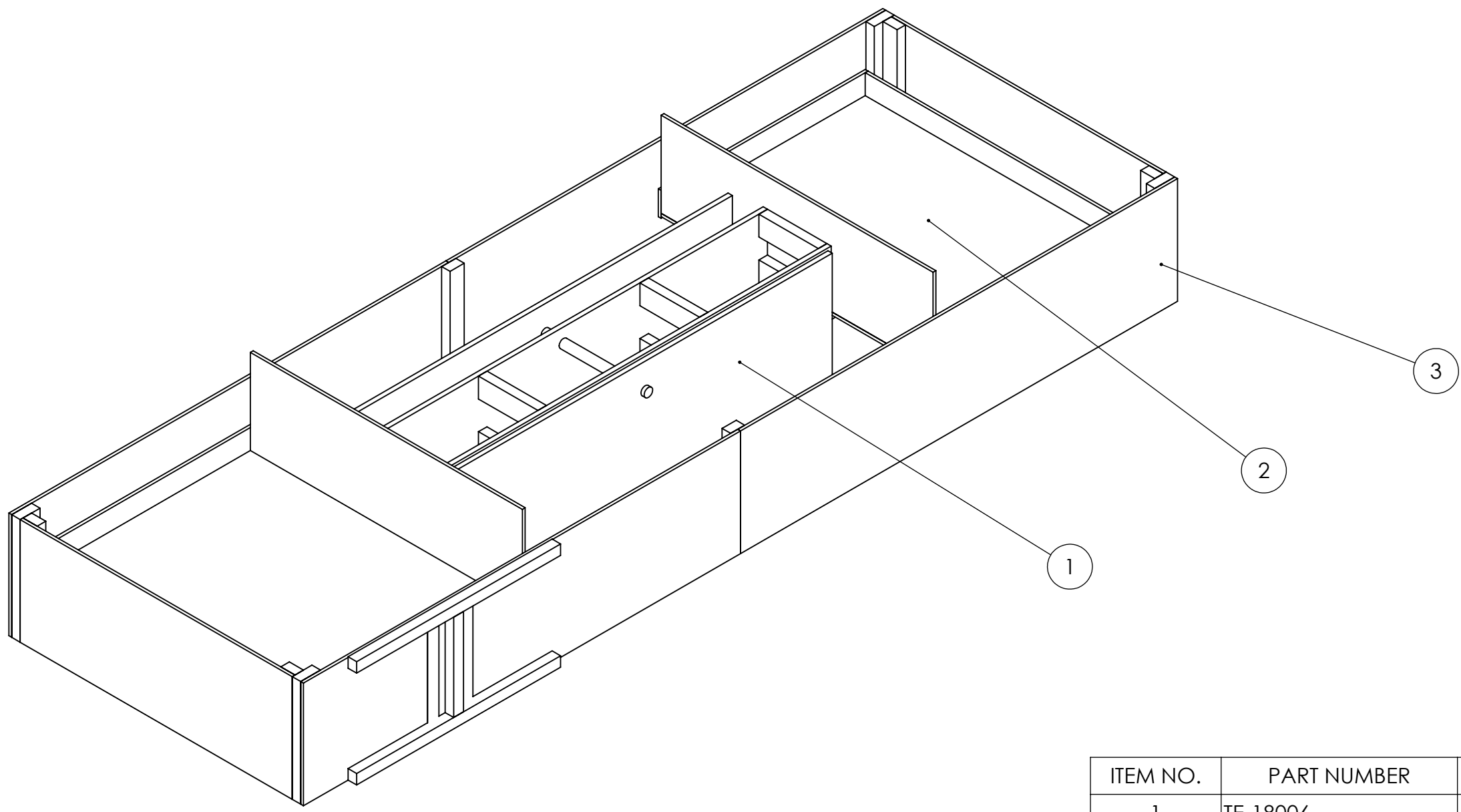



ITEM NO.	PART NUMBER	DESCRIPTION	QTY.
1	TE-18006	Switch Frame	1
2	TE-18004	Switch Arm	1
3	TE-18005	Fence	1

A

A

PROPRIETARY AND CONFIDENTIAL
 THE INFORMATION CONTAINED IN THIS DRAWING IS THE SOLE PROPERTY OF **FIRST®**. ANY REPRODUCTION IN PART OR AS A WHOLE WITHOUT THE WRITTEN PERMISSION OF **FIRST®** IS PROHIBITED.

UNLESS OTHERWISE SPECIFIED:		NAME	DATE	 
DIMENSIONS ARE IN INCHES TOLERANCES: FRACTIONAL ±1/16 ANGULAR: MACH ±1° BEND ±1° TWO PLACE DECIMAL ±.01 THREE PLACE DECIMAL ±.001		DRAWN		
INTERPRET GEOMETRIC TOLERANCING PER:		CHECKED		TITLE: <h2>Switch Full Assembly</h2>
MATERIAL		ENG APPR.		
NEXT ASSY	USED ON	MFG APPR.		SIZE B DWG. NO. TE-18013 REV
APPLICATION		FINISH		SCALE: 1:16 WEIGHT: SHEET 1 OF 2
		DO NOT SCALE DRAWING		

4

3

2

1

4

3

2

1

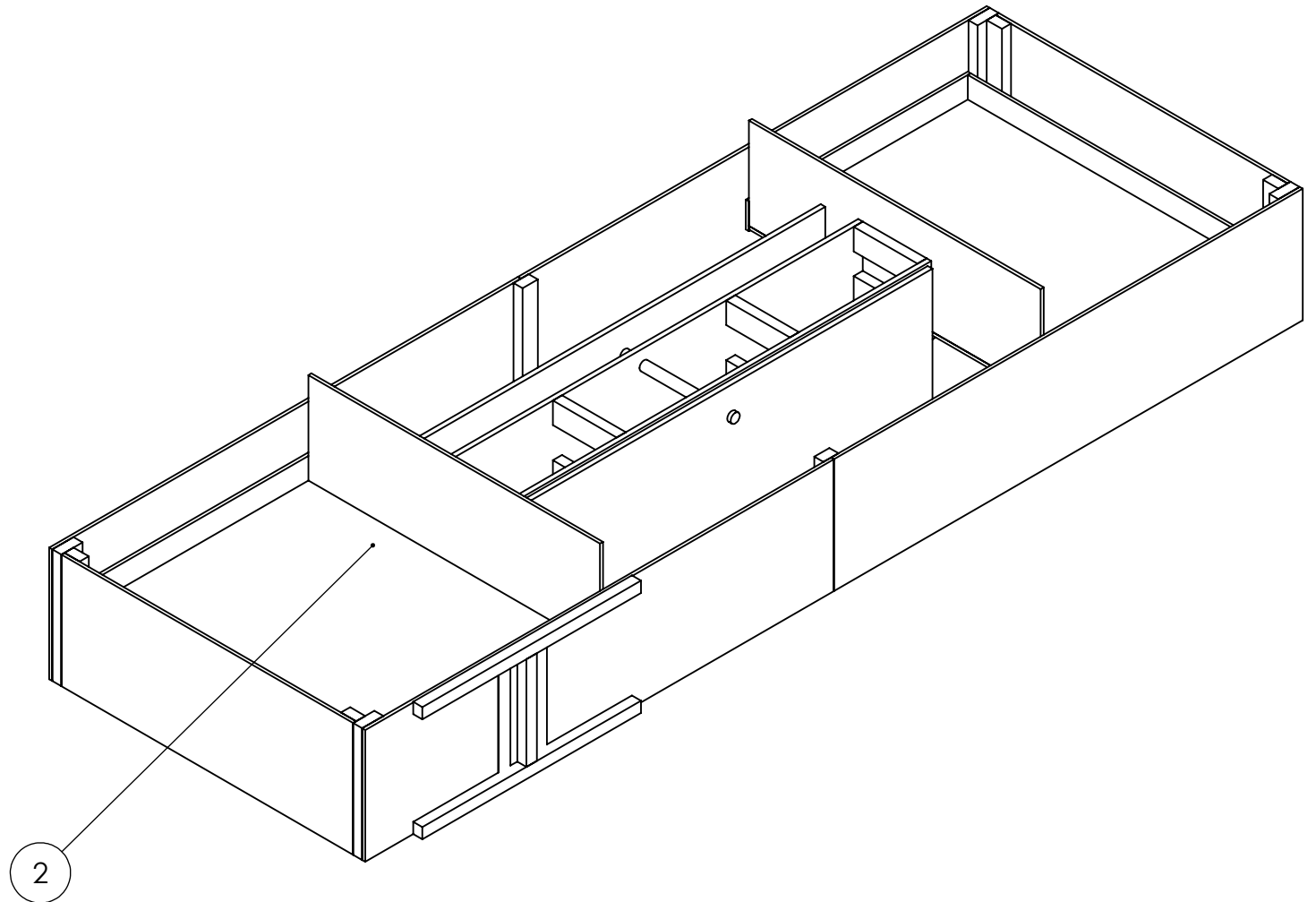
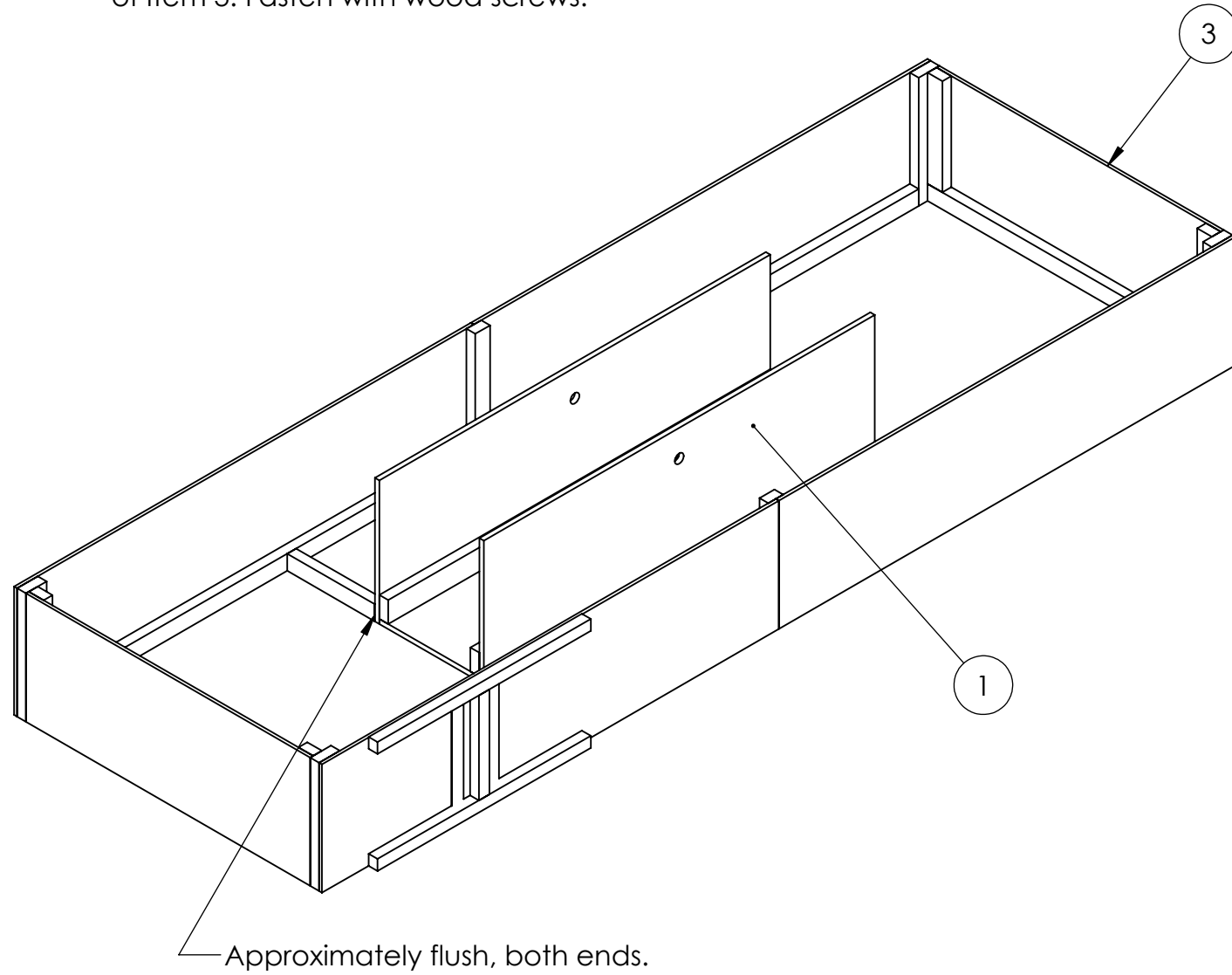

Step 1: Insert Item 1 into the middle of Item 3. Fasten with wood screws.

Step 2: Attach Item 2 to Item 1 using the shaft (TE-18004-06) from Item 1. Shaft will have to be removed prior to installation.



PROPRIETARY AND CONFIDENTIAL
 THE INFORMATION CONTAINED IN THIS DRAWING IS THE SOLE PROPERTY OF **FIRST®**. ANY REPRODUCTION IN PART OR AS A WHOLE WITHOUT THE WRITTEN PERMISSION OF **FIRST®** IS PROHIBITED.

		UNLESS OTHERWISE SPECIFIED:		NAME	DATE
		DIMENSIONS ARE IN INCHES		DRAWN	
		TOLERANCES:		CHECKED	
		FRACTIONAL ±1/16		ENG APPR.	
		ANGULAR: MACH ±1° BEND ±1°		MFG APPR.	
		TWO PLACE DECIMAL ±.01		Q.A.	
		THREE PLACE DECIMAL ±.001		COMMENTS:	
		INTERPRET GEOMETRIC TOLERANCING PER:			
		MATERIAL			
		FINISH			
NEXT ASSY	USED ON				
APPLICATION		DO NOT SCALE DRAWING			

TITLE:

Switch Full Assembly

SIZE	DWG. NO.	REV
B	TE-18013	
SCALE: 1:20 WEIGHT:		SHEET 2 OF 2

4

3

2

1

B

B

A

A

4

3

2

1

B

B

A

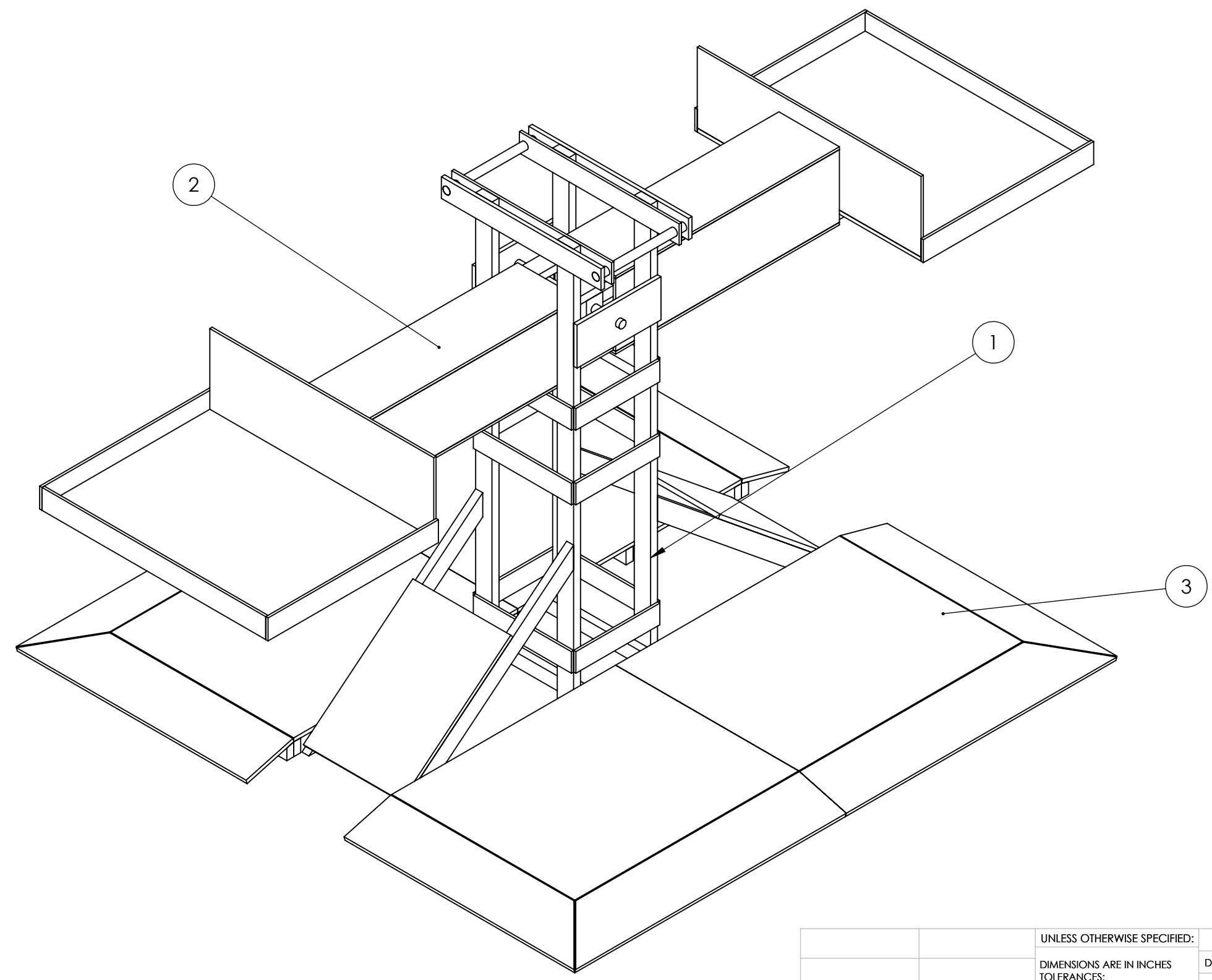

A



ITEM NO.	PART NUMBER	DESCRIPTION	QTY.
1	TE-18007	Scale Frame	1
2	TE-18008	Scale Arm	1
3	TE-18003	Platform	2

PROPRIETARY AND CONFIDENTIAL
 THE INFORMATION CONTAINED IN THIS DRAWING IS THE SOLE PROPERTY OF **FIRST®**. ANY REPRODUCTION IN PART OR AS A WHOLE WITHOUT THE WRITTEN PERMISSION OF **FIRST®** IS PROHIBITED.

UNLESS OTHERWISE SPECIFIED:		NAME	DATE
DIMENSIONS ARE IN INCHES		DRAWN	
TOLERANCES:		CHECKED	
FRACTIONAL ±1/16		ENG APPR.	
ANGULAR: MACH ±1° BEND ±1°		MFG APPR.	
TWO PLACE DECIMAL ±.01		Q.A.	
THREE PLACE DECIMAL ±.001		COMMENTS:	
INTERPRET GEOMETRIC TOLERANCING PER:	MATERIAL		
FINISH			
NEXT ASSY	USED ON		
APPLICATION	DO NOT SCALE DRAWING		

TITLE: **Scale**

SIZE **B** DWG. NO. **TE-18014** REV
 SCALE: 1:18 WEIGHT: SHEET 1 OF 3

4

3

2

1

4

3

2

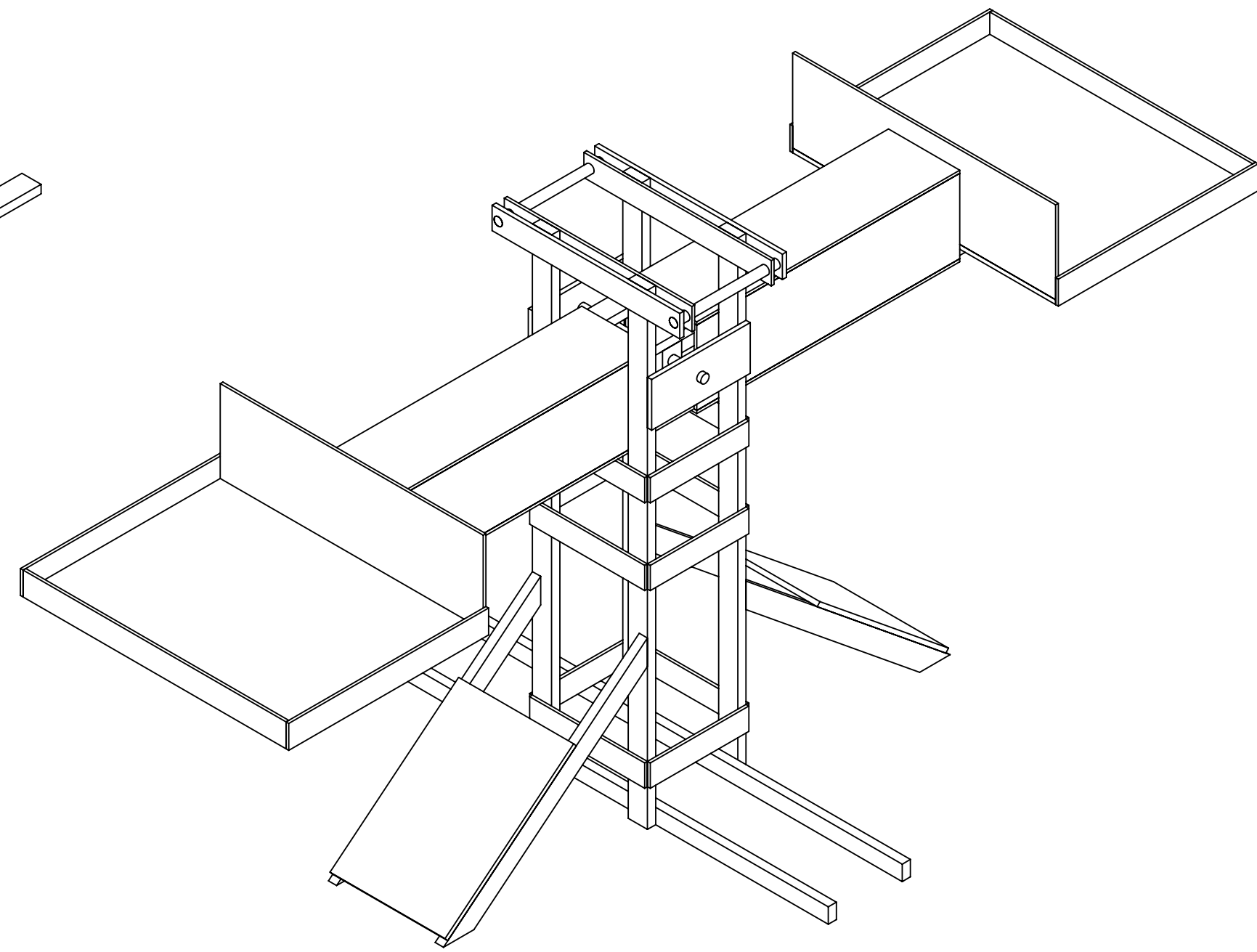
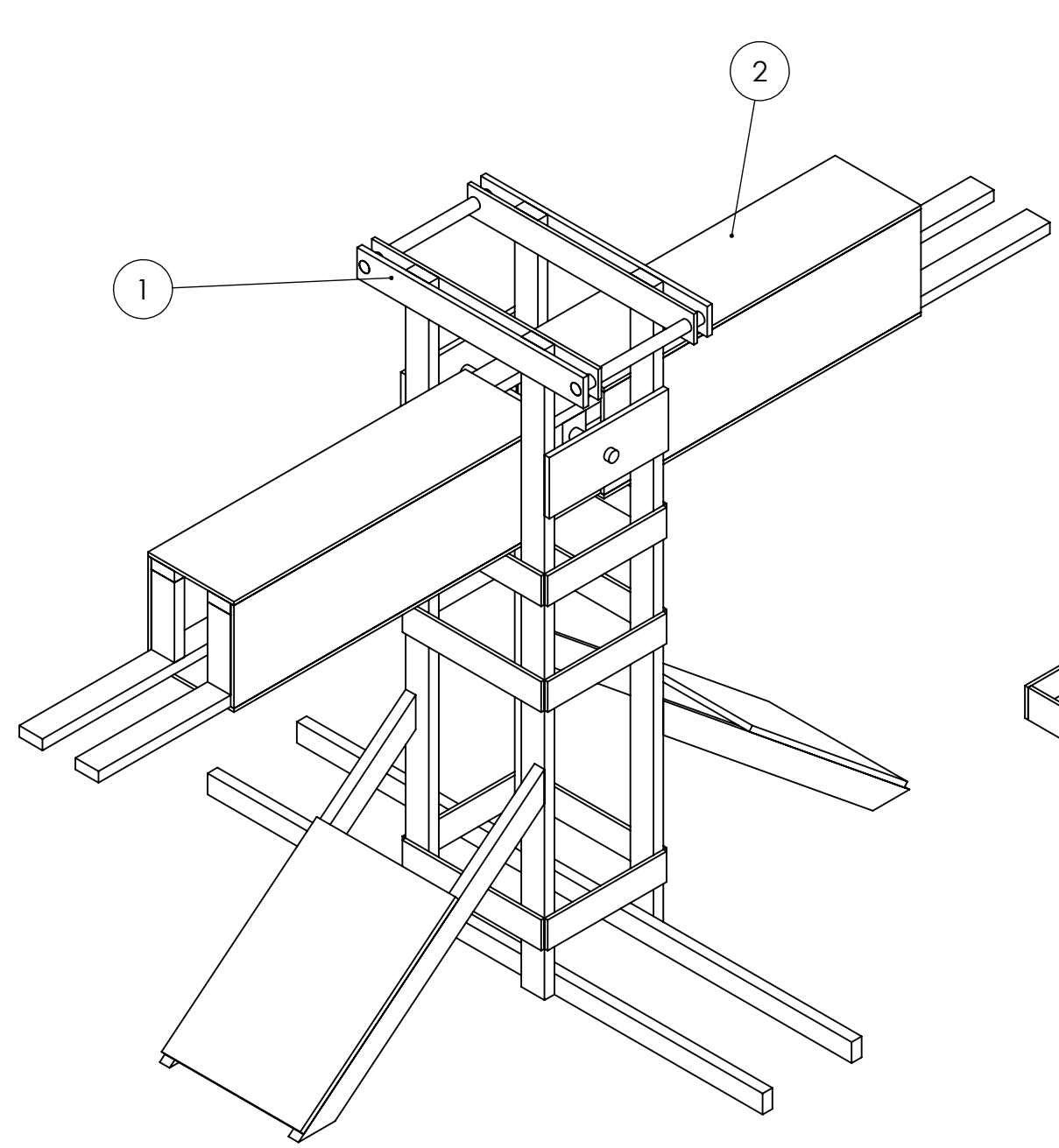

1



Step 1: Assemble Item 2 to Item 1 using the Scale Shaft (TE-18007-2). Shaft will have to be removed prior to installation.

Step 2: Complete Item 2 by attaching the Baskets (see TE-18008).

PROPRIETARY AND CONFIDENTIAL
 THE INFORMATION CONTAINED IN THIS DRAWING IS THE SOLE PROPERTY OF **FIRST®**. ANY REPRODUCTION IN PART OR AS A WHOLE WITHOUT THE WRITTEN PERMISSION OF **FIRST®** IS PROHIBITED.

		UNLESS OTHERWISE SPECIFIED:		NAME	DATE
		DIMENSIONS ARE IN INCHES		DRAWN	
		TOLERANCES:		CHECKED	
		FRACTIONAL ±1/16		ENG APPR.	
		ANGULAR: MACH ±1° BEND ±1°		MFG APPR.	
		TWO PLACE DECIMAL ±.01		Q.A.	
		THREE PLACE DECIMAL ±.001		COMMENTS:	
		INTERPRET GEOMETRIC TOLERANCING PER:			
		MATERIAL			
		FINISH			
NEXT ASSY	USED ON				
APPLICATION		DO NOT SCALE DRAWING			
		TITLE:		 	
		<h1>Scale</h1>			
SIZE	DWG. NO.	REV			
B	TE-18014				
SCALE: 1:18		WEIGHT:		SHEET 2 OF 3	

4

3

2

1

4

3

2

1

B

B

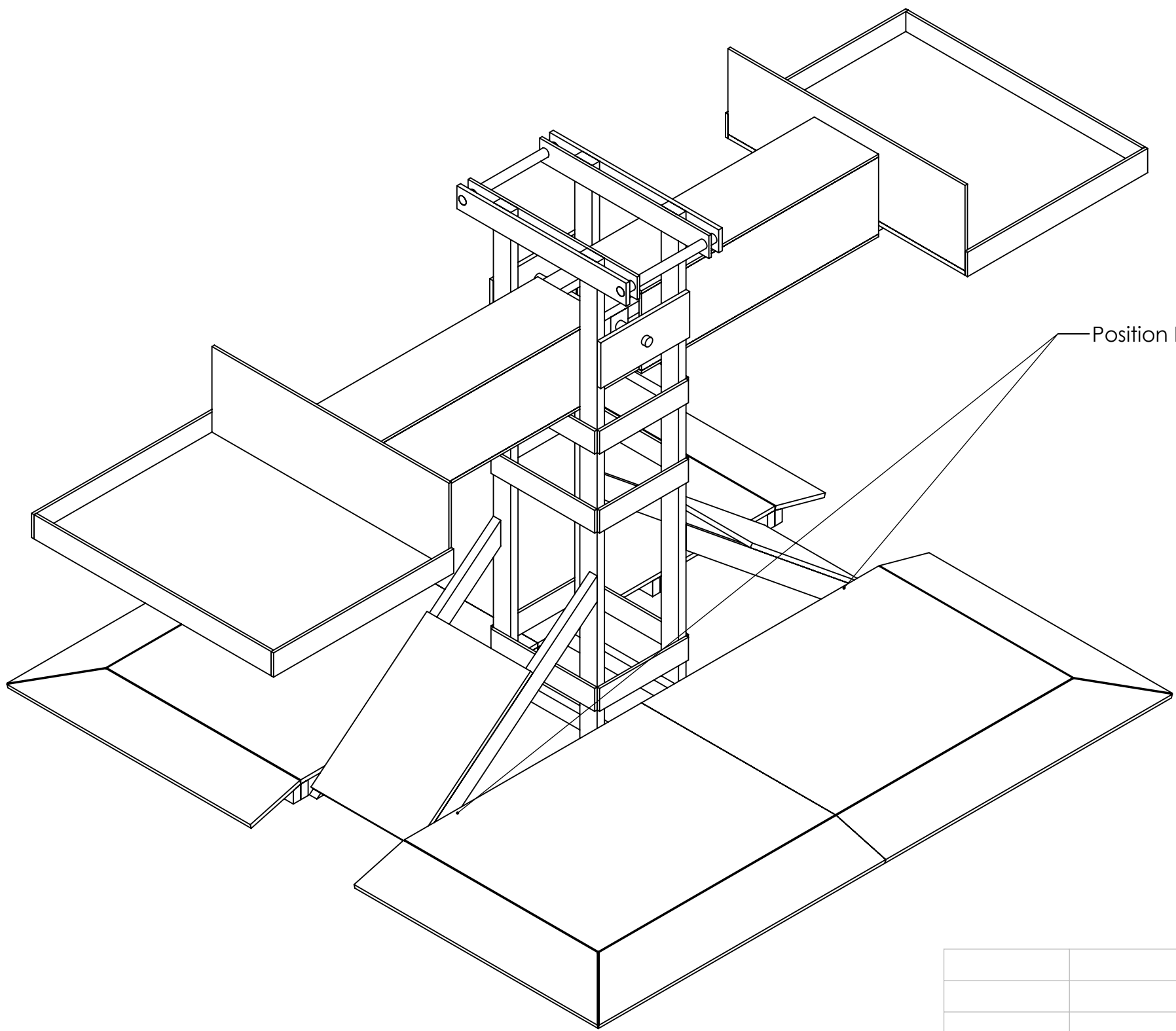



Position Item 3 flush to Item 1

Step 3: Place Item 3 (qty: 2) flush and centered against Item 1.

A

A

PROPRIETARY AND CONFIDENTIAL
 THE INFORMATION CONTAINED IN THIS DRAWING IS THE SOLE PROPERTY OF **FIRST®**. ANY REPRODUCTION IN PART OR AS A WHOLE WITHOUT THE WRITTEN PERMISSION OF **FIRST®** IS PROHIBITED.

		UNLESS OTHERWISE SPECIFIED:	NAME	DATE	 
		DIMENSIONS ARE IN INCHES TOLERANCES: FRACTIONAL ±1/16 ANGULAR: MACH ±1° BEND ±1° TWO PLACE DECIMAL ±.01 THREE PLACE DECIMAL ±.001	DRAWN		
		INTERPRET GEOMETRIC TOLERANCING PER:	CHECKED		SIZE DWG. NO. REV B TE-18014
		MATERIAL	ENG APPR.		
NEXT ASSY	USED ON	FINISH	MFG APPR.		
APPLICATION		DO NOT SCALE DRAWING	Q.A.		
			COMMENTS:		